

1. ELECTRICAL CHARACTERISTICS:
- 1-1. CURRENT RATING: 19V 2A
 - 1-2. CONTACT RESISTANCE: 10mΩ MAX.
 - 1-3. DIELECTRIC WITHSTANDING VOLTAGE: 500V AC FOR 1 MINUTE.
 - 1-4. INSULATION RESISTANCE: 100MΩ MIN. BY 500V DC.
2. MECHANICAL CHARACTERISTICS:
- 2-1. INSERTION FORCE: 3.5KGF MAX. (INITIAL / AFTER LIFE TEST)
 - 2-2. WITHDRAWAL FORCE: 0.6KGF MIN. (INITIAL / AFTER LIFE TEST)
 - 3. TEMPERATURE RISE CANT EXCEED 30° C.
 - 4. LIFE TEST: 8,000 CYCLES.
 - 5. WEIGHT: 0.64g.
 - 6. TO CONFORM TO THE SINGATRON HAZARDOUS SUBSTANCE FREE SPEC.
 - 7. HALOGEN FREE PRODUCT IDENTIFICATION LABEL ON PACKAGING.
 - 8. FOR REFLOW SOLDERING LEAD-FREE PROCESS.
 - 9. PRINTED DATE CODE "YMD" ON TOP OF CONNECTOR.
- D: DAY
M: MONTH
Y: YEAR

REV	ECN NO	OR DESCRIPTION	REVISED	DATE
A	PDR RELEASE	IV-C		2015.03.04
B	ECN NO: L150095	IV-C		2015.12.10
C	ECN NO: L160028	IV-C		2016.06.06

NO	DESCRIPTION	QTY	MATERIAL	PLATING & COLOR
E	SHELL	1	STAINLESS STEEL(SUS301)	NI: 50U"MIN.
D	CONTACT-R	1		
C	CONTACT-M	1	COPPER ALLOY(C18400)	GOLD FLASH ON CONTACT AREA; WHITE SN 50-100μ" ON SOLDER ALL OVER IN 50U" MIN.
B	CONTACT-L	1		
A	HOUSING	1	PA4T UL94V-0	BLACK

UNLESS OTHERWISE SPECIFIED TOLERANCES

Singatron Enterprise Co., Ltd.
信音企業股份有限公司

TITLE: DC POWER JACK

DRAWN: DW-C 2016.06.06 PART NO. 2DC1560-000111F
CHKD: AWB 2016.06.06 SCALE: 4:1 UNIT: mm
APVD: AWB 2016.06.06 SIZE: A3 SHEET: 1 OF 2 REV: C

RECOMMEND P.C.B LAYOUT(T=0.8mm)
TOP VIEW (TOLERANCES:±0.05)

CUSTOMER COPY

REV.	ECN NO OR DESCRIPTION	REVISED	DATE
A	PDR RELEASE	IWY-C	2015.03.04
B	ECN NO: L150095	IWY-C	2015.12.10
C	ECN NO: L160028	IWY-C	2016.06.06

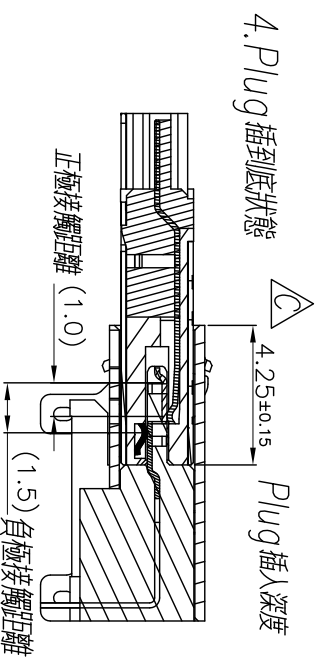
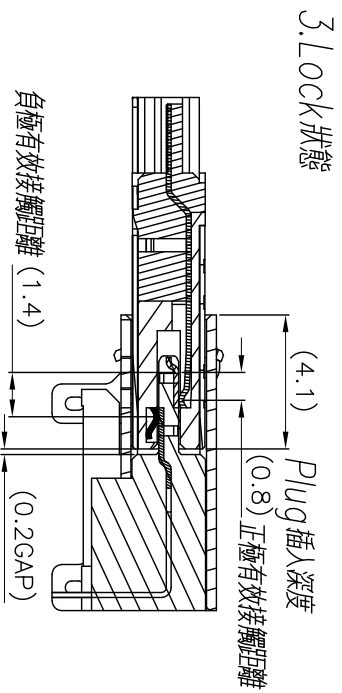
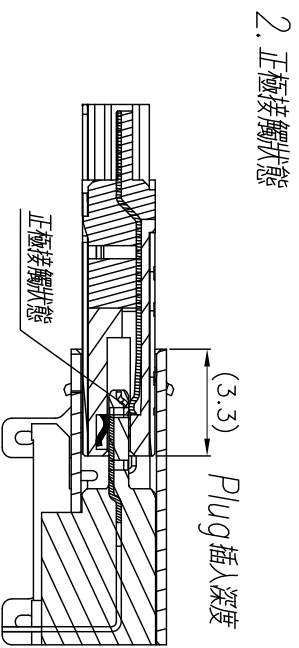
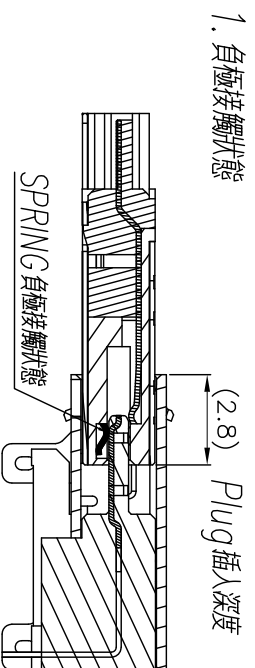

NO	DESCRIPTION	QTY	MATERIAL	PLATING & COLOR
UNLESS OTHERWISE SPECIFIED TOLERANCES				
DECIMALS: ANGLES:				
X	:±0.5	X	:±2°	
XX	:±0.3	X.X	:±1°	
XXX	:±0.2			
TITLE DC POWER JACK MATING DRAWING				
DWN	HW-4 2016.06.06	PART NO. 2DC1560-000111F		
CHKD	HW-4 2016.06.06	SCALE:	UNIT: mm	
APVD	HW-4 2016.06.06	SIZE: A3	SHEET: 2 OF 2	REV: C

CUSTOMER COPY

Singatron Enterprise Co., Ltd.
信音企業股份有限公司