

REV.	ECN NO OR DESCRIPTION	REVISED	DATE
A	PRODUCT RELEASE	ALLEN	2011.04.18
B	ECN: C110393 Modify tip	Longjiang	2012.01.10

SPECIFICATIONS:

1. ELECTRICAL CHARACTERISTICS:

- 1-1. RATING: 20V 5A
- 1-2. CONTACT RESISTANCE: 30m MAX. (INITIAL)
- 1-3. DIELECTRIC WITHSTANDING VOLTAGE: 500V AC FOR ONE MINUTE.
- 1-4. INSULATION RESISTANCE: 100M MIN. MEASURED BY 500 VDC

2. MECHANICAL CHARACTERISTICS:

- 2-1. INSERTION FORCE : 0.4~3.0 KGF
- 2-2. WITHDRAWAL FORCE : 0.4~3.0 KGF
- 3. LIFE TEST: 5,000 CYCLES MIN.

4. TO CONFORM TO SINGATRON HAZARDOUS SUBSTANCE FREE SPEC.

5. HALOGEN FREE PRODUCT IDENTIFICATION MARK ON PRODUCT:

6. HALOGEN FREE PRODUCT IDENTIFICATION LABEL ON PACKAGING:

7. FOR HAND SOLDERING LEAD-FREE PROCESS.

8. PRINTED DATE CODE"



WAMPD CONNECTOR

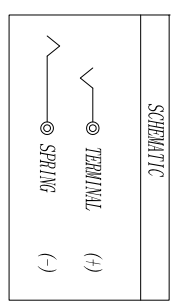
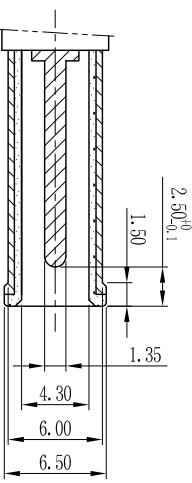
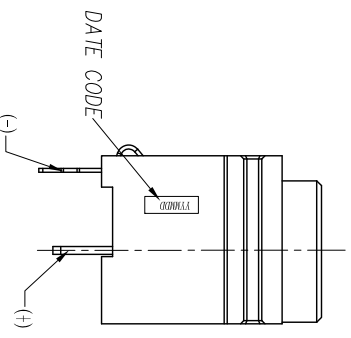
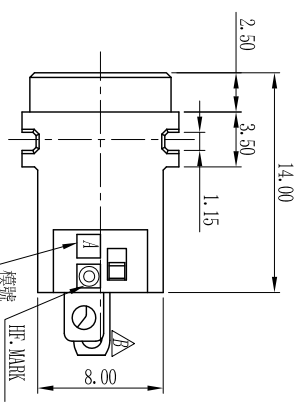
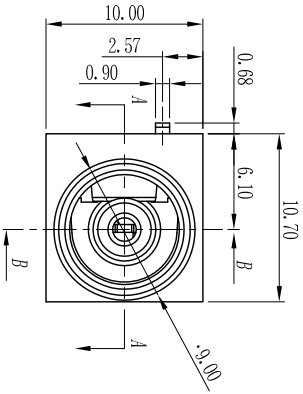
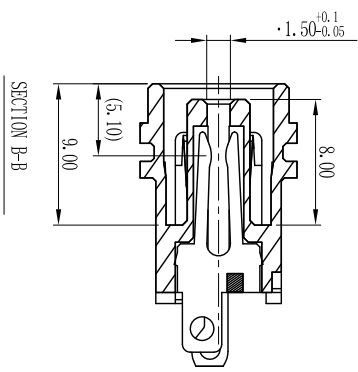
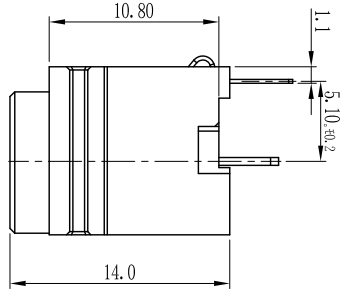
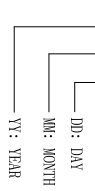

NO	DESCRIPTION	QTY	MATERIAL	PLATING & COLOR
C	TERMINAL	1	COPPER ALLOY 0.5T	Ag PLATING
B	TIP SPRING	1	COPPER ALLOY 0.25T	Ag PLATING
A	BODY	1	THERMOPLASTIC	BLACK

UNLESS OTHERWISE SPECIFIED TOLERANCES

信亨企業股份有限公司
Singatron Enterprise Co., Ltd.

DC POWER JACK

DECIMALS:	ANGLES:	PART NO.	UNIT:	REV:
X : ±0.5	X : ±2°	20X2001-008111F	mm	B
X.X : ±0.3	X.X : ±1°	SCALE 3:1	mm	
X.XX : ±0.2		SIZE: A3	SHEET: 1 OF 1	

CUSTOMER COPY