

REV.	ECN NO.	OR DESCRIPTION	REVISED	DATE
A		PRODUCT RELEASE	LIPING	2012.05.09
B	ECN: C120294	Modify shell	longjiaing	2012.10.22

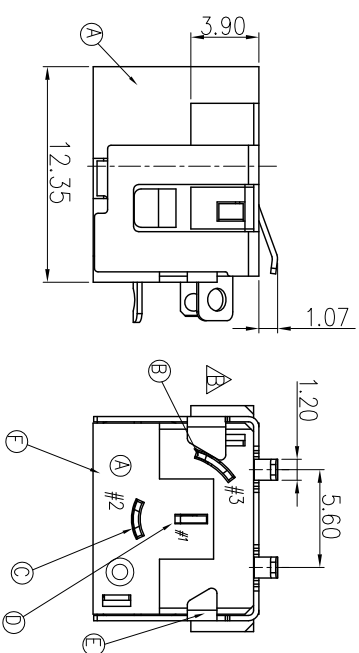

- SPECIFICATIONS:**
- ELECTRICAL CHARACTERISTICS:**
 - RATING: 10A MAX.
 - RATING: 20V DC.
 - CONTACT RESISTANCE: 30 mΩ Max.
 - INSULATION RESISTANCE: 100 MΩ Min.
 - DIELECTRIC WITHSTANDING VOLTAGE: 150V AC FOR 1 MINUTE.
 - MECHANICAL CHARACTERISTICS:**
 - INSERTION FORCE : 3.0 KGF MAX .
 - WITHDRAWAL FORCE : 0.35 KGF MIN.
 - LIFE TEST: 5,000 CYCLES MIN.
 - OPERATING TEMPERATURE: -40°C TO 85°C
 - OTHER GENERAL SPEC. TO REFER "2DC2018- 002111F".
 - TO CONFORM TO SINGATRON HAZARDOUS SUBSTANCE FREE SPEC.
 - HALOGEN FREE PRODUCT IDENTIFICATION MARK ON PRODUCT:
 - HALOGEN FREE PRODUCT IDENTIFICATION LABEL ON PACKAGING:
 - FOR HAND SOLDERING LEAD-FREE PROCESS.
 - PACKAGING: BAG

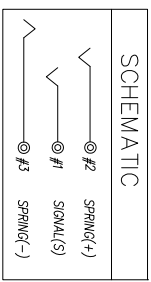
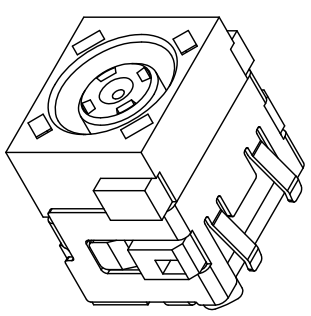
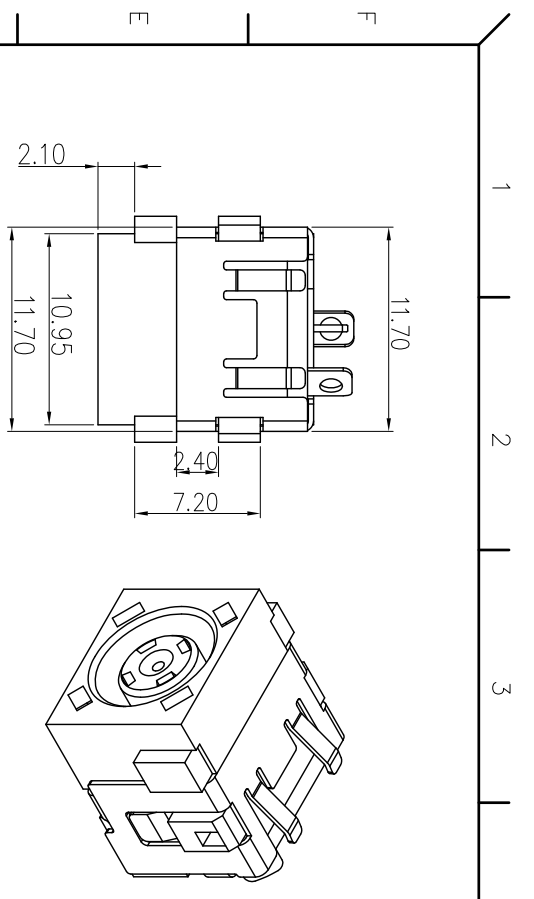
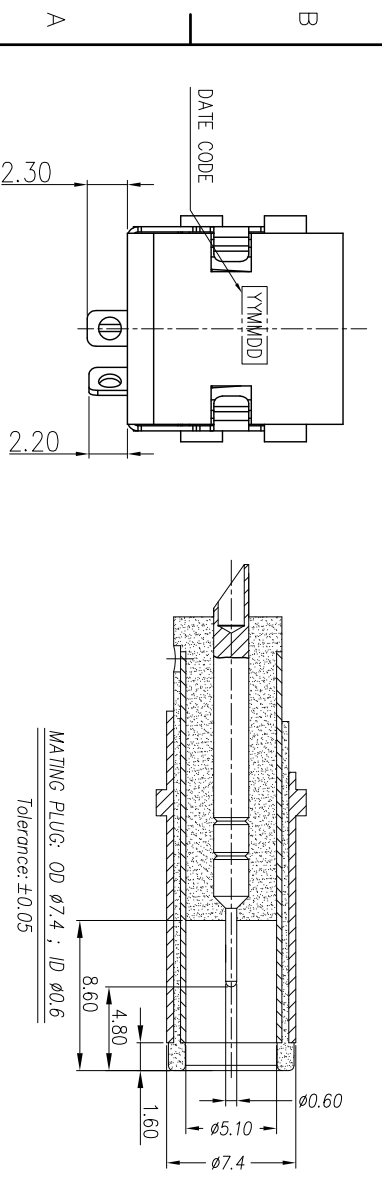

MATING PLUG: OD $\phi 7.4$; ID $\phi 0.6$
Tolerance: ± 0.05

F	COVER	1	THERMOPLASTIC	BLACK
E	SHELL	1	COPPER ALLOY	NICKEL PLATING
D	SIGNAL(S)	1	COPPER ALLOY	Gold flash on contact area;
C	SPRING(+)	1	COPPER ALLOY	Bright tin on solder tail area;
B	SPRING(-)	1	COPPER ALLOY	all over Nickel plated.
A	BODY	1	THERMOPLASTIC	BLACK
NO	DESCRIPTION	QTY	MATERIAL	PLATING & COLOR

UNLESS OTHERWISE SPECIFIED TOLERANCES



Singatron Enterprise Co., Ltd.
信音企業股份有限公司

DECIMALS:	ANGLES:	TITLE	DC POWER JACK
X : ± 0.5	X : $\pm 2^\circ$	DWN	longjiaing 12.10.24
XX : ± 0.3	XX : $\pm 1^\circ$	CHKD	Zp 12.10.24
XXX : ± 0.2		APVD	liao 12.10.24

CUSTOMER COPY