

REV: A	ECN NO. OR DESCRIPTION: PRODUCT RELEASE	REVISED: Longjiang 2013.10.23	DATE:
--------	---	-------------------------------	-------

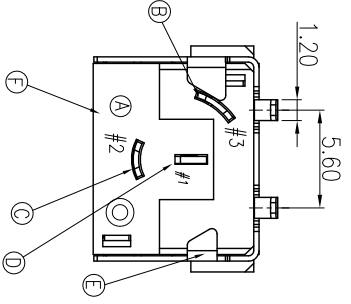

2. MECHANICAL CHARACTERISTICS:
- 2-1. INSERTION FORCE : 0.7~2.0 KGF .
 - 2-2. WITHDRAWAL FORCE : 0.7~2.0 KGF
- LIFE TEST AFTER:
- 2-1. WITHDRAWAL FORCE : 0.5~2.0 KGF
 - 2-2. WITHDRAWAL FORCE : 0.5~2.0 KGF
3. LIFE TEST: 15,000 CYCLES MIN.
4. OPERATING TEMPERATURE: -40°C TO 85°C
5. OTHER GENERAL SPEC. TO REFER "2DC2018 - 006111F".
6. TO CONFORM TO SINGATRON HAZARDOUS SUBSTANCE FREE SPEC.
7. HALOGEN FREE PRODUCT IDENTIFICATION MARK ON PRODUCT: (C)
8. HALOGEN FREE PRODUCT IDENTIFICATION LABEL ON PACKAGING: (C)
9. FOR HAND SOLDERING LEAD-FREE PROCESS.
10. PACKAGING: BAG

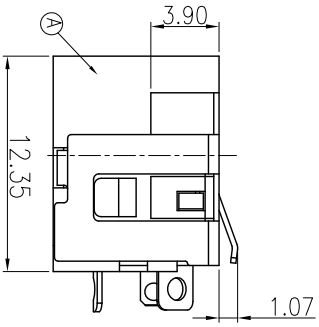
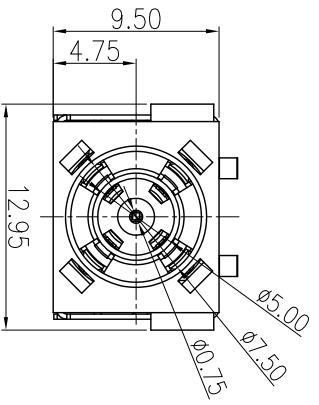
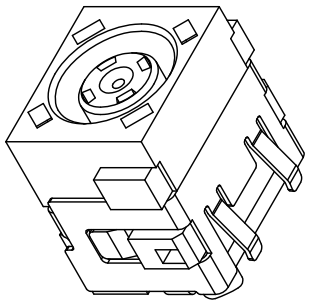
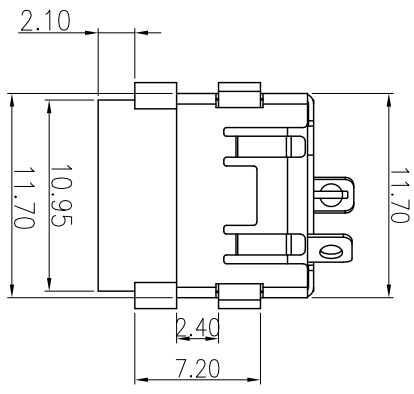
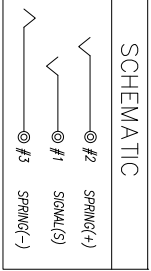
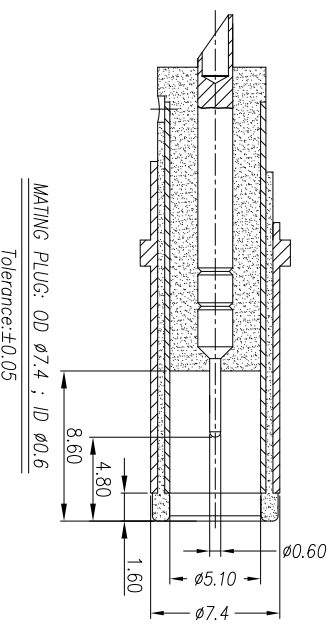
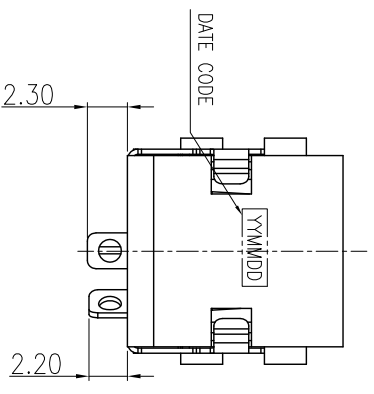

F	COVER	1	THERMOPLASTIC	BLACK
E	SHELL	1	COPPER ALLOY	NICKEL PLATING
D	SIGNAL(S)	1	COPPER ALLOY	Gold flash on contact area;
C	SPRING(+)	1	COPPER ALLOY	bright tin on solder tail area;
B	SPRING(-)	1	COPPER ALLOY	all over Nickel plated.
A	BODY	1	THERMOPLASTIC	BLACK
NO	DESCRIPTION	QTY	MATERIAL	PLATING & COLOR

UNLESS OTHERWISE SPECIFIED TOLERANCES

Singatron Enterprise Co., Ltd.
信音企業股份有限公司

TITLE	DC POWER JACK			
DWN	Longjiang 13/11/13	PART NO.	2DC2018-006111F	
CHKD	ziz 13/11/13	SCALE	3:1	UNIT: mm
APVD	lsh 13/11/13	SIZE:	A3	SHEET: 1 OF 1 REV: A

CUSTOMER COPY

