

REV.	ECN NO OR DESCRIPTION	REVISED	DATE
A	PRODUCT RELEASE	Shunzhong	2019.03.11

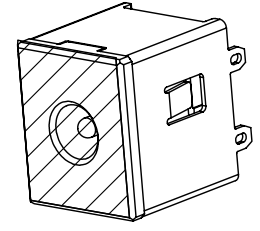

- SPECIFICATIONS:
- ELECTRICAL CHARACTERISTICS:
    - RATING CURRENT: 4A
    - RATING VOLTAGE: 24V
    - CONTACT RESISTANCE: 30mΩ(INITIAL), 50mΩ(AFTER LIFE TEST).
    - DIELECTRIC WITHSTANDING VOLTAGE: 500 VAC FOR ONE MINUTE.
    - INSULATION RESISTANCE: 100MΩ MIN. BY 500 VDC.
  - MECHANICAL CHARACTERISTICS:
    - INSERTION FORCE: 1.0kgf~2.5kgf
    - WITHDRAWAL FORCE: 0.5kgf~2.5kgf
    - LIFE TEST: 5,000 CYCLES
  - ENVIRONMENTAL CHARACTERISTICS:
    - SALT MIST TEST CONDITION: PER IEC 68-2-52, SEVERITY(3).
    - OPERATING TEMPERATURE: -30°~+80°.
    - TO CONFORM TO SINGATRON HAZARDOUS SUBSTANCE FREE SPEC.
    - ROHS COMPLIANT PRODUCT.
    - HALOGEN FREE PRODUCT IDENTIFICATION MARK: ©
    - HALOGEN FREE PRODUCT IDENTIFICATION LABEL ON PACKAGING:
  - OTHER GENERAL SPEC. TO REFER "2DC2037-001111F SPEC."
  - FOR REFLOW SOLDERING LEAD-FREE PROCESS.
  - FAI NO. MARK: Ⓢ
  - CPK NO. MARK: ▽ (DIM. NO.:3/22/23/34/49/50/53)
  - COG.: CENTER OF GRAVITY.
  - PACKAGING: TAPE & REEL.

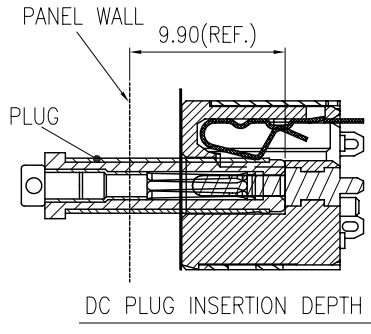
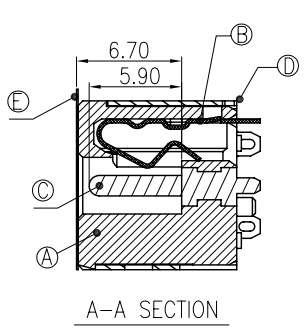
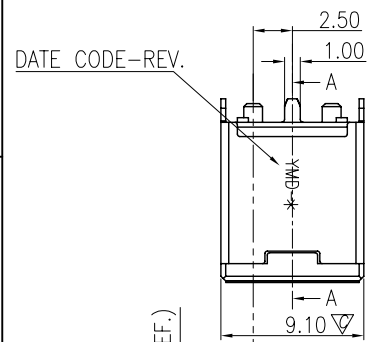
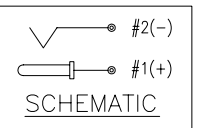
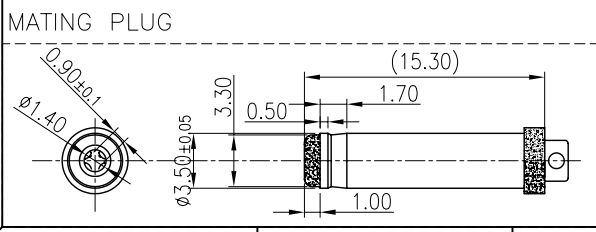
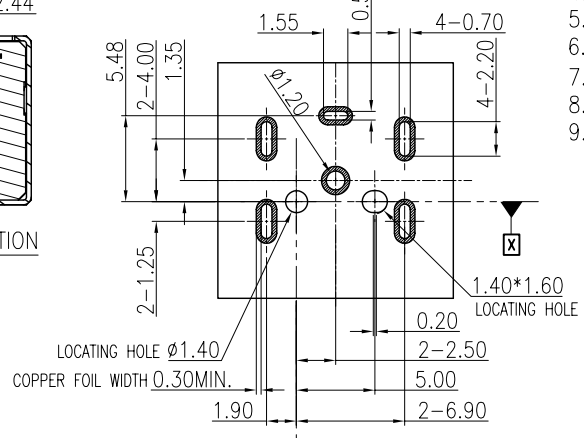
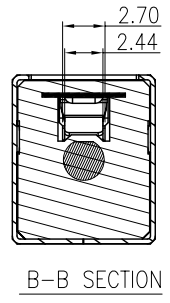
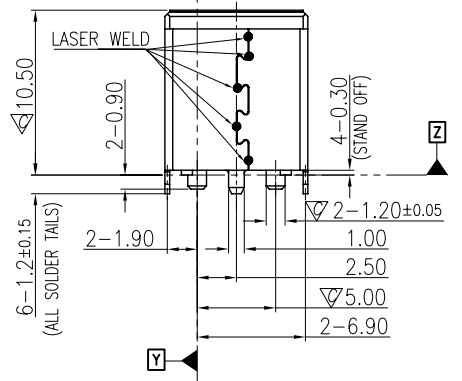
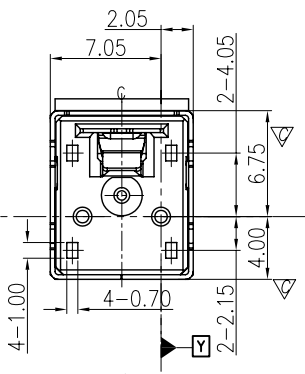
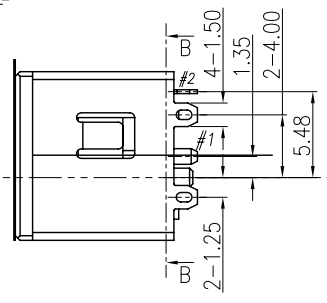
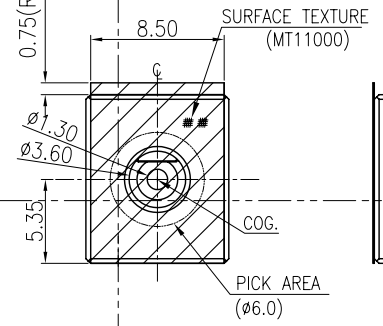

RECOMMENDED PCB LAYOUT  
(TOP VIEW)(TOL.: ±0.05)

NO.	DESCRIPTION	QTY.	MATERIAL	PLATING & COLOR
A	BODY	1	PA4T-GF30 FR(40) UL94V-0 (DSM)	BLACK
B	TIP SPRING	1	YCUT-FX-EH T=0.25	AU 2u" MIN. ON CONTACT AREA, SN 120u" MIN. ON SOLDER TAIL AREA ALL OVER NI 60u" MIN. PLATING.
C	PIN	1	HBI59-1.5B(NON-ANNEALED)	NI 60u" MIN. PLATING
D	SHELL	1	SUS304-3/4H T=0.3	NI 60u" MIN. PLATING
E	MYLAR	1	T=0.1	YELLOW (TRANSPARENT)

UNLESS OTHERWISE SPECIFIED TOLERANCES		Singatron Enterprise Co., Ltd. 信音企業股份有限公司			
DECIMALS:	ANGLES:	TITLE: DC POWER RECEPTACLE			
X :±0.5	X :±2°	DWN	ShunZhong-Yuon 19/03/13	PART NO. 2DC2037-001111F	
X.X :±0.3	X.X :±1°	CHKD	Stone-Zhu 19/03/13	SCALE 3:1	UNIT: mm
X.XX :±0.2		APVD	Jim-deng 19/03/13	SIZE: A3	SHEET: 10F1 REV:A
CUSTOMER COPY					