

REV.	ECN NO OR DESCRIPTION	REVISED	DATE
A	PDR NO.:S190128-3A	Jie	2019.06.03

SPECIFICATIONS:

- ELECTRICAL CHARACTERISTICS:
 - RATING: 20V 10A
 - CONTACT RESISTANCE: 30mΩ MAX.
 - DIELECTRIC WITHSTANDING VOLTAGE: 500V AC FOR ONE MINUTE.
 - INSULATION RESISTANCE: 100MΩ MIN. MEASURED BY 500 VDC
- MECHANICAL CHARACTERISTICS:
 - INSERTION FORCE: 2.5 Kgf MAX.
 - WITHDRAWAL FORCE: 0.8~2.0Kgf.
- TEMPERATURE RISE CAN'T EXCEED 30°C
- LIFE TEST: 5,000 CYCLES.
- WEIGHT: 2.6g
- TO CONFORM TO SINGATRON HAZARDOUS SUBSTANCE FREE SPEC.
- GREEN PRODUCT IDENTIFICATION MARK ON JACK:
- GREEN PRODUCT IDENTIFICATION LABEL ON PACKAGING:
- FOR HAND SOLDERING LEAD-FREE PROCESS.
- PRINTED DATE CODE "SYYYMMDD".

SINGATRON ← →
 DD: DAY
 MM: MONTH
 YY: YEAR

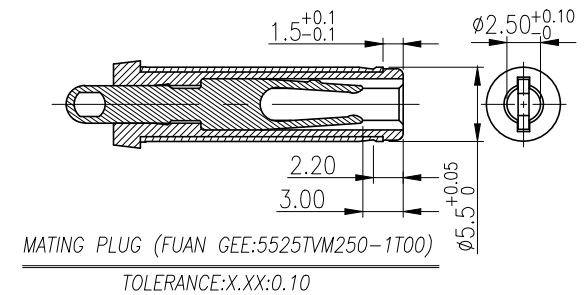
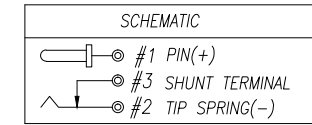

NO	DESCRIPTION	QTY	MATERIAL	PLATING & COLOR
G	GROUNDING	1	STAINLESS 0.1T	N/A
F	SHIELDING	1	BRASS 0.35T	Ni 60u"
E	PIN	1	BRASS	Au 30u" OVER Ni 50u"
D	STOPPER	1	HIGH TEMP. THERMOPLASTIC	N/A
C	SHUNT TERMINAL	1	BRASS STRIP 0.3T	Gold Flash On Contact Area.Sn 80u/Min On Solder Tail. All Over Ni 50u/Min.
B	TIP SPRING	1	COPPER ALLOY 0.25T	Au 30" On Contact Area.Sn 80u/Min On Solder Tail. All Over Ni 50u/Min.
A	BODY	1	HIGH TEMP. THERMOPLASTIC	BLACK

UNLESS OTHERWISE SPECIFIED TOLERANCES

Singatron Enterprise Co., Ltd.
 信音企業股份有限公司

DECIMALS:	ANGLES:	TITLE	DC JACK	
X :±0.5	X :±2°	DWN Jie	PART NO.2DC3003-022211F	
X.X :±0.3	X.X :±1°	CHKD	SCALE 1:1	UNIT: mm
X.XX :±0.2		APVD	SIZE: A3	SHEET:1 OF 2 REV: A
CUSTOMER COPY				

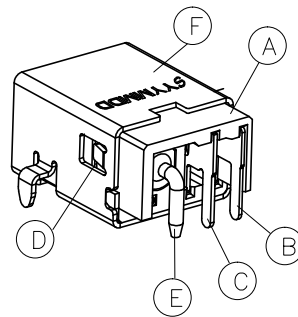
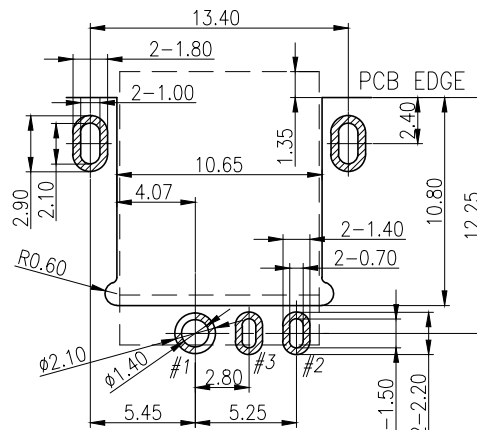
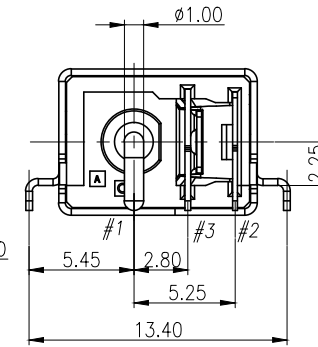
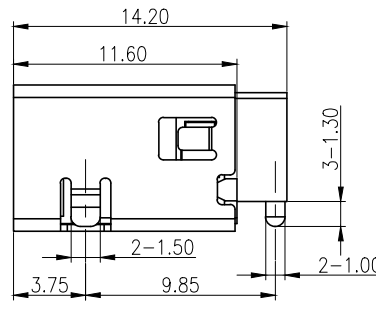
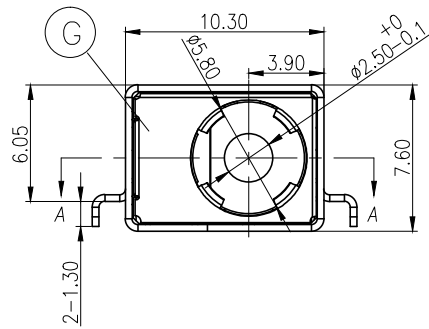
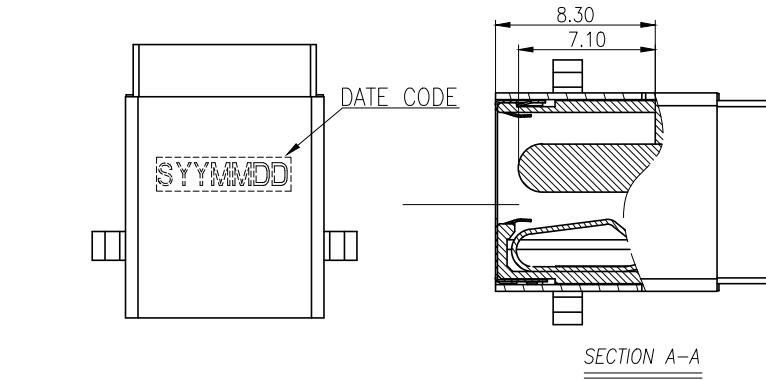
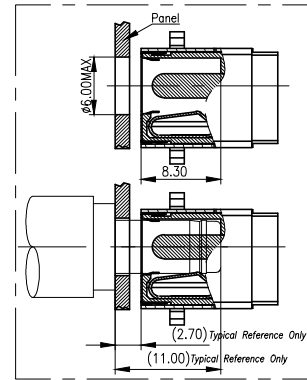

REV.	ECN NO OR DESCRIPTION	REVISED	DATE
A	PDR NO.:S190128-3A	Jie	2019.06.03

1. GROUND接觸狀態

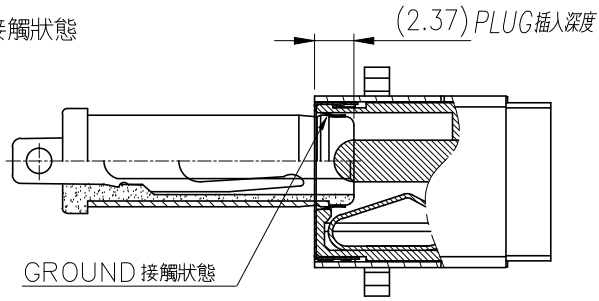

4. LOCK 狀態

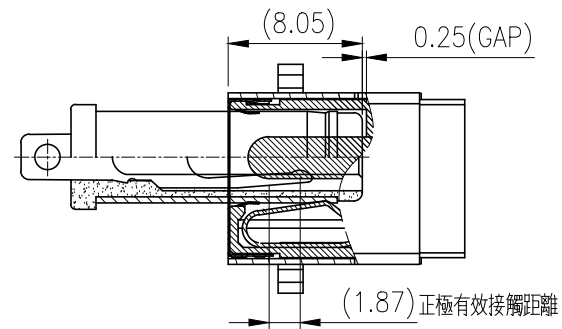

2. PIN正極接觸狀態

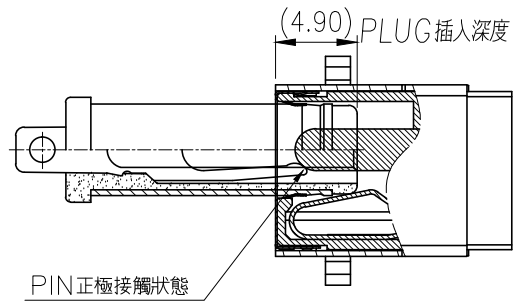

5. PLUG FULL MATING

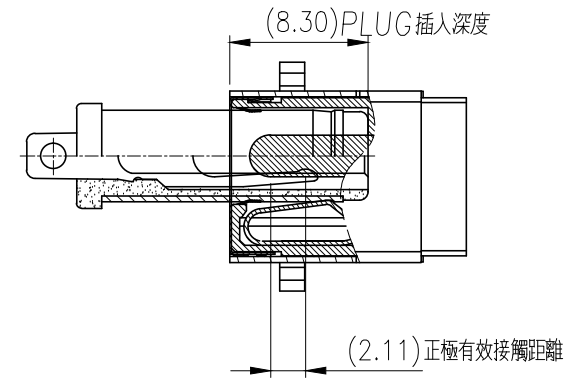

3. SPRING負極接觸狀態

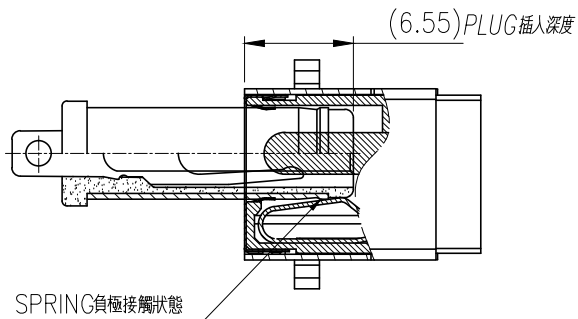

UNLESS OTHERWISE SPECIFIED TOLERANCES		 Singatron Enterprise Co., Ltd. 信音企業股份有限公司	
DECIMALS:	ANGLES:	TITLE	MATING DRAWING
X :±0.5	X :±2°	DWN	Jie PART NO. 2DC3003-022211F
X.X :±0.3	X.X :±1°	CHKD	SCALE 4:1 UNIT: mm
X.XX :±0.2		APVD	SIZE: A3 SHEET: 2 OF 2 REV: A
CUSTOMER COPY			