

REV.	ECN NO OR DESCRIPTION	REVISED	DATE
A	PDR NO:T120821-3A	Eileen	2012.09.26
B	ECN NO:S130218	SEAN	2013.05.13

- SPECIFICATIONS:
- ELECTRICAL CHARACTERISTICS:
 - RATING: 20V 7A
 - CONTACT RESISTANCE: 30mΩ MAX.(INITIAL)
 - DIELECTRIC WITHSTANDING VOLTAGE: 500V AC FOR ONE MINUTE.
 - INSULATION RESISTANCE: 100MΩ MIN. MEASURED BY 500 VDC
 - MECHANICAL CHARACTERISTICS:
 - MECHANICAL WITHDRAWAL FORCE : 1.0~2.5KG/10~25N(INITIAL), 0.5~2.5KG/5~25N(AFTER LIFE TEST).
 - LIFE TEST: 10,000 CYCLES MIN.
 - TO CONFORM TO SINGATRON HAZARDOUS SUBSTANCE FREE SPEC.
 - GREEN PRODUCT IDENTIFICATION MARK ON JACK:
 - GREEN PRODUCT IDENTIFICATION LABEL ON PACKAGING:
 - PRINTED DATE CODE: "YYMMDD" ON TOP OF CONNECTOR.

SECTION A-A

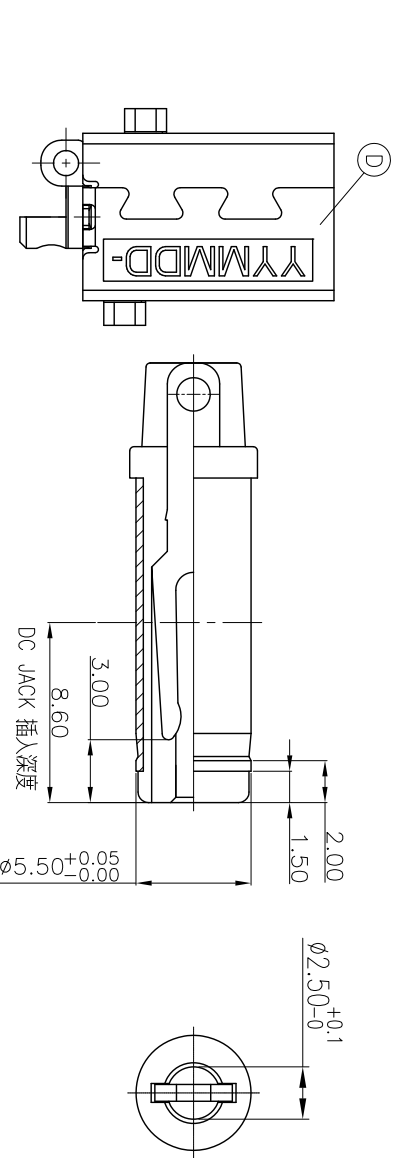
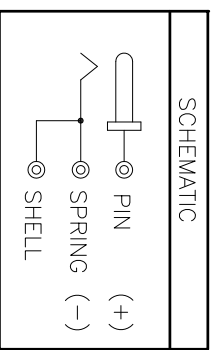
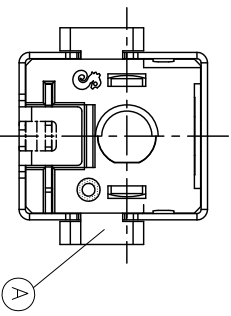
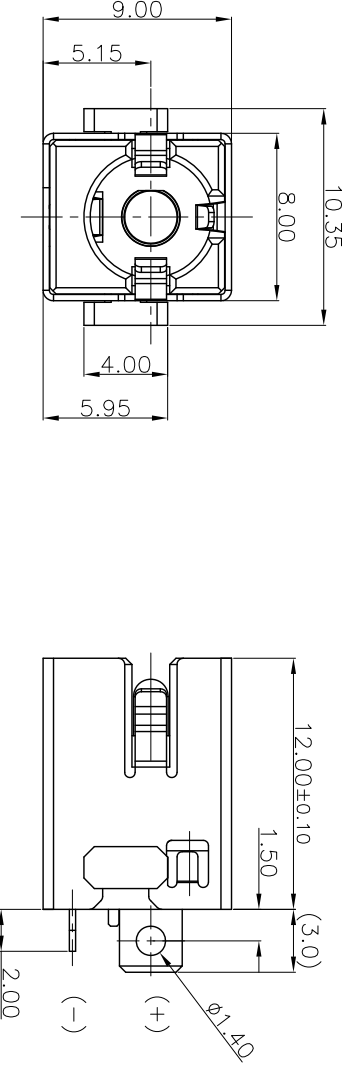
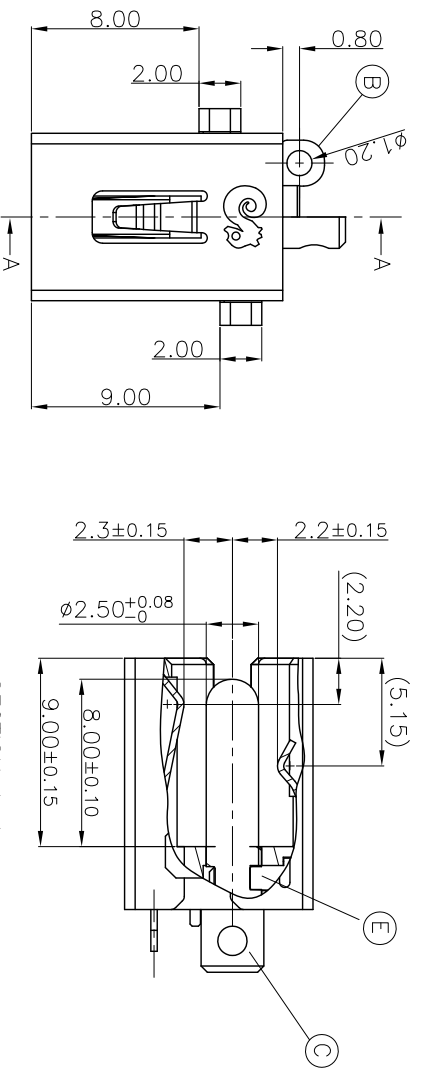

MATING PLUG
(TOLERANCE ±0.05)

NO	DESCRIPTION	QTY	MATERIAL	PLATING & COLOR
E	STOPPER	1	HIGH TEMP. THERMOPLASTIC UJ94V-0	BLACK
D	SHELL	1	STAINLESS, T=0.3	Ni 80u" Min.
C	PIN	1	BRASS	GOLD FLASH 1u" Min.
B	SPRING	1	PHOSPHOR BRONZE, T=0.30	Au 1u" Min. on Contact Area, Sn 100u" Min. on Solder Tail, Over Nickel 50u" Min. plating.
A	BODY	1	HIGH TEMP. THERMOPLASTIC UJ94V-0	BLACK

UNLESS OTHERWISE SPECIFIED TOLERANCES	ANGLES:
DECIMALS:	
X : ±0.5	X : ±2°
X.X : ±0.3	X.X : ±1°
X.XX : ±0.2	

TITLE	DC POWER JACK
DWN	SEAN
CHKD	CERRY
APVD	MAX
PART NO.	2DC3005-009111F
SCALE:	4:1
UNIT:	mm
SIZE:	A3
SHEET:	1 OF 1
REV:	B

Singatron Enterprise Co., Ltd.
信音企業股份有限公司

CUSTOMER COPY