

REV.	ECN NO OR DESCRIPTION	REVISED	DATE
C	ECN NO:S101005	ANDY	2010.12.01
D	ECN NO:S120430	Danfeng	2012.04.05
E	ECN NO:S120540	SEAN	2012.06.11

NO	DESCRIPTION	QTY	MATERIAL	PLATING & COLOR
E	STOPPER	1	HIGH TEMP. THERMOPLASTIC.U194V-0	BLACK
D	SHELL	1	STAINLESS. T=0.3	N/A
C	PIN	1	BRASS	G/F 1u" Min.
B	SPRING	1	PHOSPHOR BRONZE.T=0.30	Au 1u" Min. on Contact Area. Sn 100u" Min. on Solder Tail. Over Nickel 50u" Min. plating.
A	BODY	1	HIGH TEMP. THERMOPLASTIC.U194V-0	BLACK

UNLESS OTHERWISE SPECIFIED TOLERANCES

DECIMALS: ANGLES:

X : ±0.5 X : ±2°

X.X : ±0.3 X.X : ±1°

X.XX : ±0.2

DC POWER JACK

PART NO. 2DC3005-001111

SCALE:4:1

UNIT: mm

SIZE: A3



SHEET:1 OF 2

REV:E

P/N	DM A
2DC3005-001111	Ø2.50
2DC3005-000111	Ø1.65

REV.	ECN NO OR DESCRIPTION	REVISED	DATE
C	ECN NO:S101005	ANDY	2010.12.01
D	ECN NO:S120430	Danfeng	2012.04.05
E	ECN NO:S120540	SEAN	2012.06.11

SPECIFICATIONS:

- ELECTRICAL CHARACTERISTICS:
 - RATING: 20V 7A
 - CONTACT RESISTANCE: 30mΩ MAX.(INITIAL)
 - DIELECTRIC WITHSTANDING VOLTAGE: 500V AC FOR ONE MINUTE.
 - INSULATION RESISTANCE: 100MΩ MIN. MEASURED BY 500 VDC
- MECHANICAL CHARACTERISTICS:
 - INSERTION/WITHDRAWAL FORCE(BEFORE) : 1.0~3.0 KG.
 - INSERTION/WITHDRAWAL FORCE(AFTER) : 0.5 KG MIN.
 - LIFE TEST: 10,000 CYCLES MIN.
 - TO CONFORM TO SINGATRON HAZARDOUS SUBSTANCE FREE SPEC.
 - GREEN PRODUCT IDENTIFICATION MARK ON JACK: 
 - GREEN PRODUCT IDENTIFICATION LABEL ON PACKAGING: 
 - PRINTED DATE CODE"  " ON TOP OF CONNECTOR.

DATE CODE: 

DD: DAY
MM: MONTH
YY: YEAR

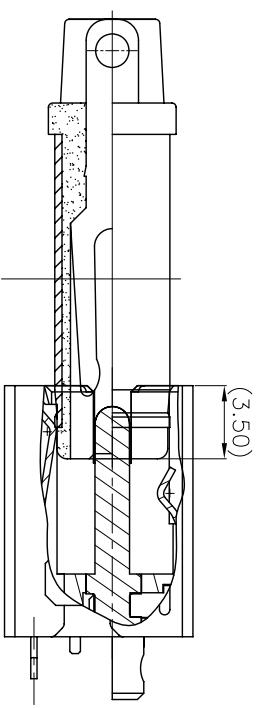

<1.>WIPING DISTANCE FOR GROUND CONTACT

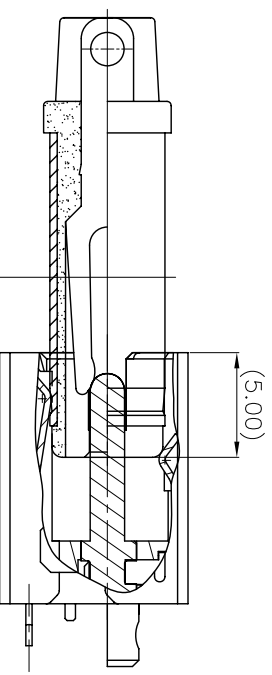

<2.>WIPING DISTANCE FOR POWER CONTACT

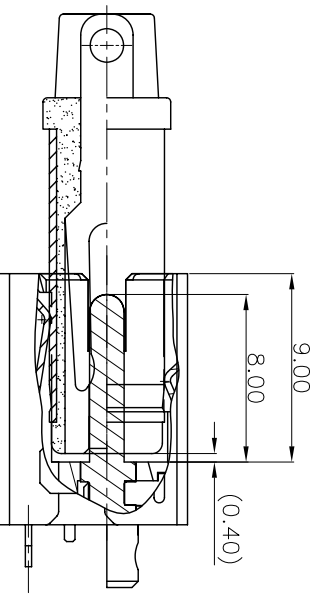

<3.>THE PLUG CAN INSERT THE CONNECTOR

MATING DRAWING

NO	DESCRIPTION	QTY	MATERIAL	PLATING & COLOR
UNLESS OTHERWISE SPECIFIED TOLERANCES				
DECIMALS: ANGLES:				
X	:±0.5	X	:±2°	
X.X	:±0.3	X.X	:±1'	
X.XX	:±0.2			
TITLE	DC POWER JACK			
DWN	SEAN	PART NO.	2DC3005-00	□111
CHKD	TOM	SCALE:	4:1	UNIT: mm
APVD	TONY	SIZE:	A3	SHEET: 2 OF 2 REV:E
CUSTOMER COPY				

 Singatron Enterprise Co., Ltd.
信普企業股份有限公司