

- SPECIFICATIONS:**
- ELECTRICAL CHARACTERISTICS:**
 - 1-1. RATING: 30VDC 11A
 - 1-2. CONTACT RESISTANCE: 20mΩ MAX. (INITIAL)
 - 1-3. JACK SHALL WITHSTAND 500 V AC BETWEEN ANY ADJACENT TERMINAL (EXCEPT LEAD) FOR ONE MINUTE.
 - 1-4. INSULATION RESISTANCE: 100MΩ MIN. MEASURED BY 500 VDC
 - MECHANICAL CHARACTERISTICS:**
 - 2-1. INSERTION FORCE : 2.5 KGF MAX.
 - 2-2. WITHDRAWAL FORCE : 0.8 KGF MIN. (INITIAL)
 3. LIFE TEST: 5,000 CYCLES MIN.
 4. OTHER GENERAL SPEC. TO REFER "2DC3007-208111F SPEC."
 5. TO CONFORM TO SINGATRON HAZARDOUS SUBSTANCE FREE SPEC.
 6. GREEN PRODUCT IDENTIFICATION MARK ON JACK:
 7. GREEN PRODUCT IDENTIFICATION LABEL ON PACKAGING:
 8. FOR HAND SOLDERING LEAD-FREE PROCESS.
 9. THE PANEL'S ID MUST BE GREATER THAN THE PLUG'S OD WHICH MUST HAVE A DIFFERENCE OF LESS THAN OR EQUAL TO 0.5 mm. (AS SHOWN IN FIGURE 1.)

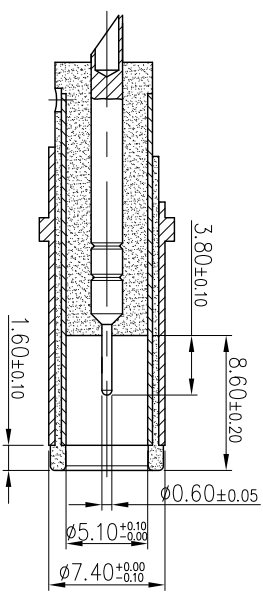
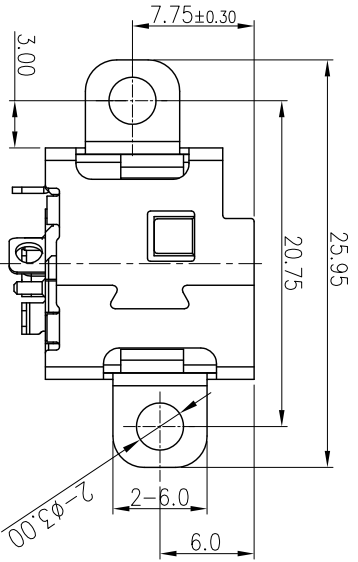
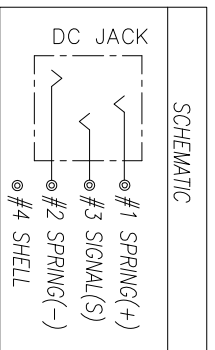
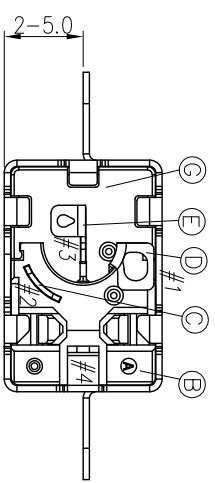
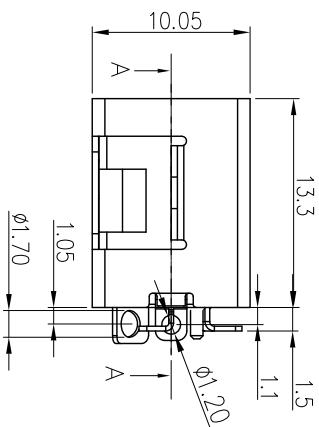
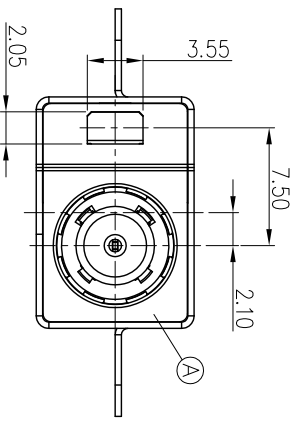

MATING PLUG

G	BACK PLATE	1	THERMOPLASTIC UL 94V-0 (HALOGEN FREE)	BLACK
F	SHELL	1	SPCC-SD 0.4T	Ni 60u" Min OVER CU 80U" Min
E	SIGNAL	1	COPPER ALLOY 0.3T	Ni (50u" Min.) UNDERPLATED OVER ALL Pd/Ni (25u" Min.) & GOLD-PLATED(5u" Min.) AT CONTACT AREA.
D	SPRING(+)	1	C7035 0.3T	AND Matte Sn 120u" Min. ON SOLDER TAIL.
C	SPRING(-)	1	C7035 0.3T	
B	COVER	1	THERMOPLASTIC UL 94V-0 (HALOGEN FREE)	BLACK
A	HOUSING	1		
NO	DESCRIPTION	QTY	MATERIAL	PLATING & COLOR

UNLESS OTHERWISE SPECIFIED TOLERANCES

Singatron Enterprise Co., Ltd.
信音企業股份有限公司

DECIMALS: ANGLES:

X : ±0.5 X : ±2°
X.X : ±0.3 X.X : ±1°
X.XX : ±0.2

TITLE	DC POWER JACK
DWN	Springwu
CHKD	Sky
APVD	Lussen
PART NO.	2DC3007-208111F
SCALE:	4:1
UNIT:	mm
SIZE:	A3
SHEET:	10F2
REV:	A

CUSTOMER COPY

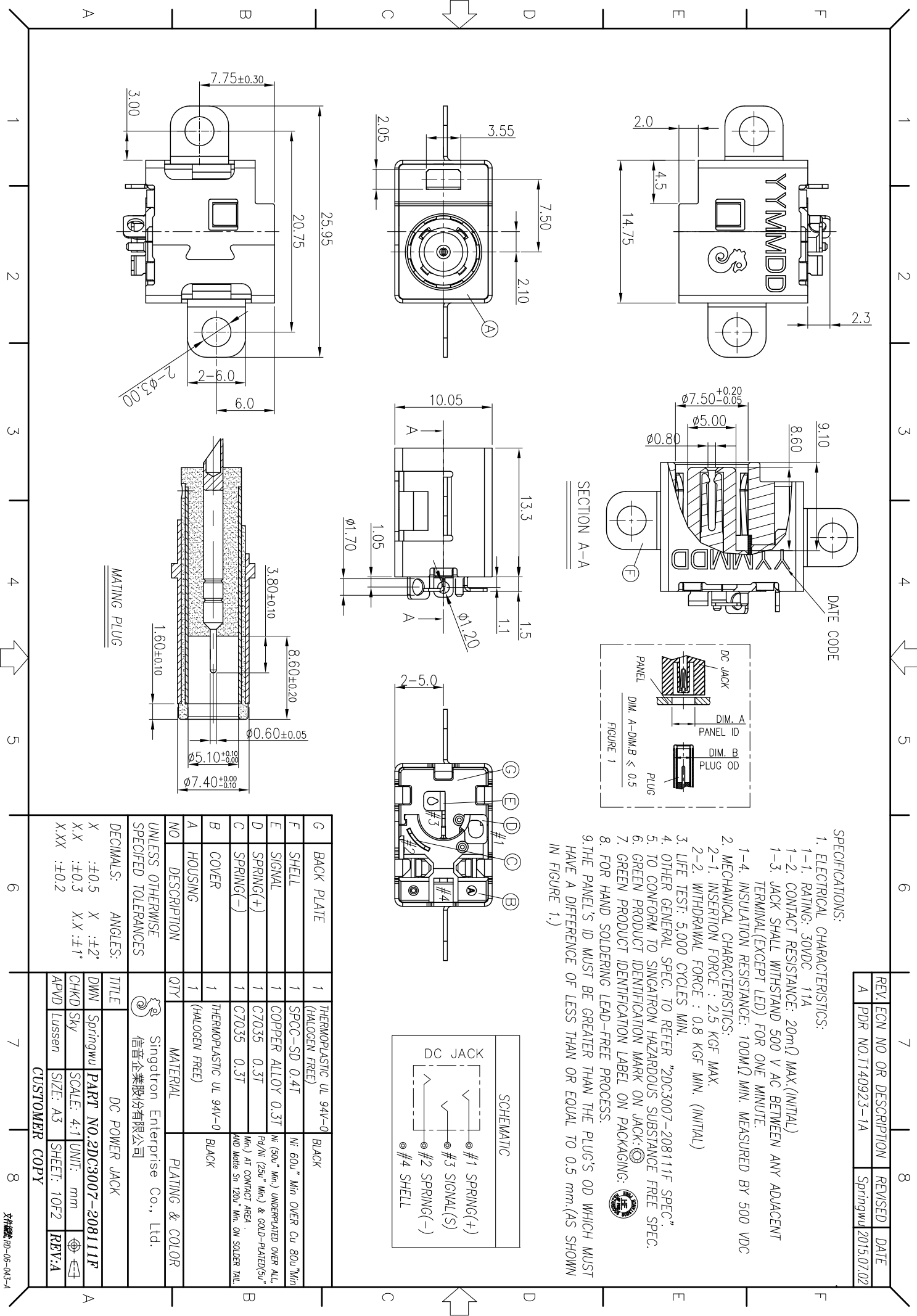

REV.	ECN NO.	OR DESCRIPTION	REVISED	DATE
A	PDR	NO:T140923-1A	Springwu	2015.7.3

1. Negative contact first

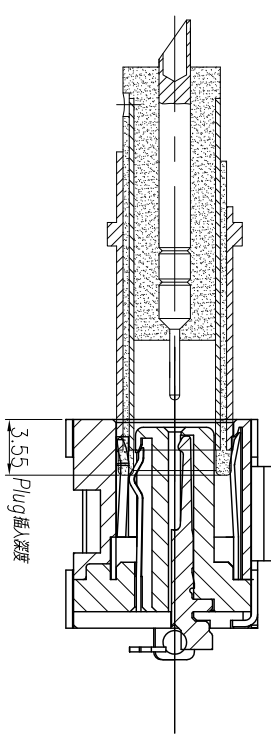

2. Positive contact second

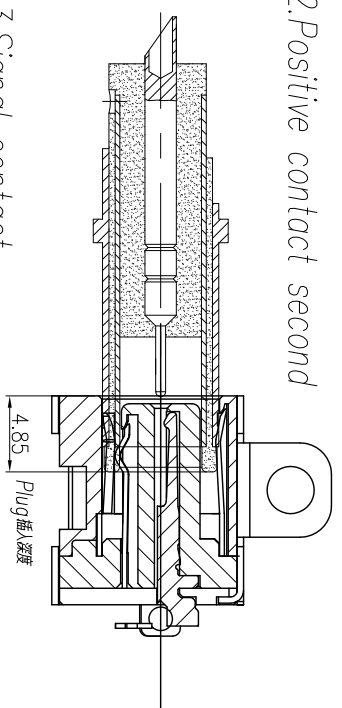

3. Signal contact

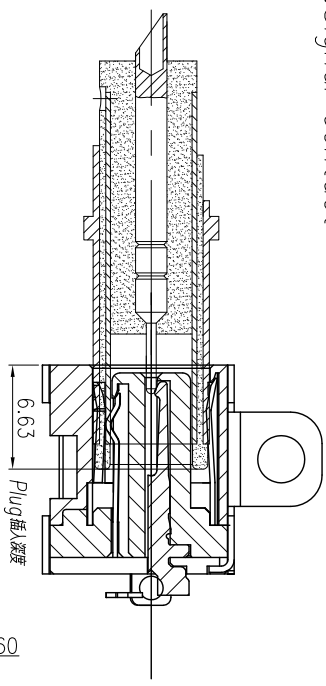

4. Lock position

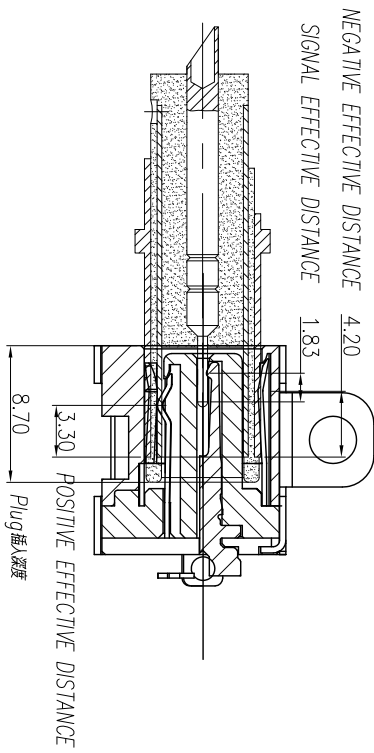

5. Plug full insertion

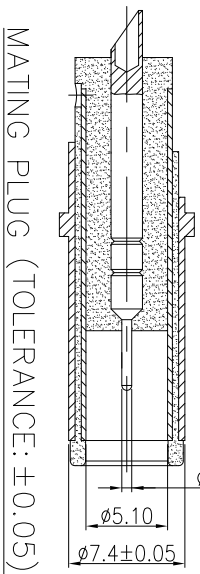
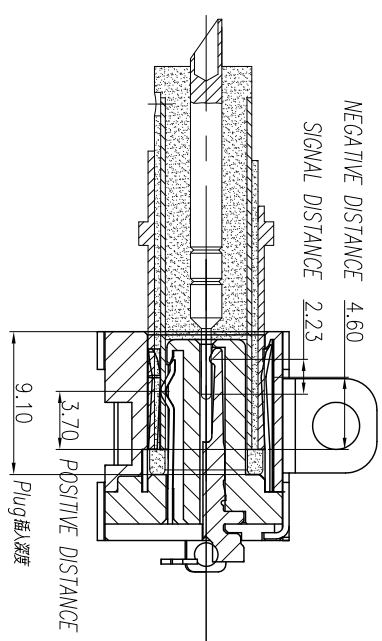

MATING PLUG (TOLERANCE: ± 0.05)

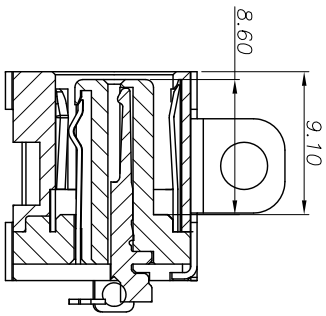

PART NO. 2DC3007-208111F

NO	DESCRIPTION	QTY	MATERIAL	PLATING & COLOR
	UNLESS OTHERWISE SPECIFIED TOLERANCES		Singatron Enterprise Co., Ltd.	
	DECIMALS:		ANGLES:	
X	± 0.5	X	$\pm 2^\circ$	
X.X	± 0.3	X.X	$\pm 1^\circ$	
X.XX	± 0.2			
	TITLE		DC JACK	
DWN	Springwu		PART NO. 2DC3007-208111F	
CHKD	Sky		SCALE 1:1	UNIT: mm
APVD	Lussen		SIZE: A3	SHEET: 20F2
			REV: A	

CUSTOMER COPY