

REV.	ECN NO.	OR DESCRIPTION	REVISED	DATE
A	PDR NO: T170907-3A		Qizhen	2018.6.4
B	ECN NO: S190427-C		Qizhen	2019.6.5

- SPECIFICATIONS:**
- ELECTRICAL CHARACTERISTICS:
 - RATING: DC 20V, 7A
 - CONTACT RESISTANCE: 30mΩ MAX.(INITIAL)
 - DIELECTRIC WITHSTANDING VOLTAGE: 500V AC FOR ONE MINUTE.
 - INSULATION RESISTANCE: 100MΩ MIN. MEASURED BY 500 VDC
 - MECHANICAL CHARACTERISTICS:
 - INSERTION FORCE : 3.0 KG Max
 - WITHDRAWAL FORCE : 0.35KG MIN
 - LIFE TEST: 5,000 CYCLES MIN.
 - OTHER GENERAL SPEC. TO REFER "20CC3061 SERIES SPEC."
 - TO CONFORM TO SINGATRON HAZARDOUS SUBSTANCE FREE SPEC.
 - HALOGEN FREE PRODUCT IDENTIFICATION MARK ON PRODUCT
 - HALOGEN FREE PRODUCT IDENTIFICATION LOGO ON THE PACKAGING:
 - FOR REFLOW SOLDERING LEAD-FREE PROCESS.
 - PRINTED DATE CODE "YMMIDD" ON TOP OF CONNECTOR.

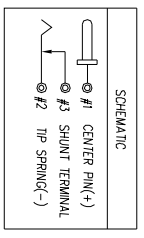
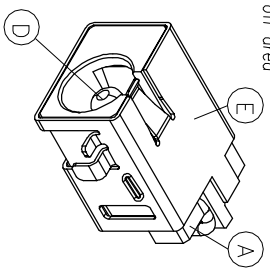
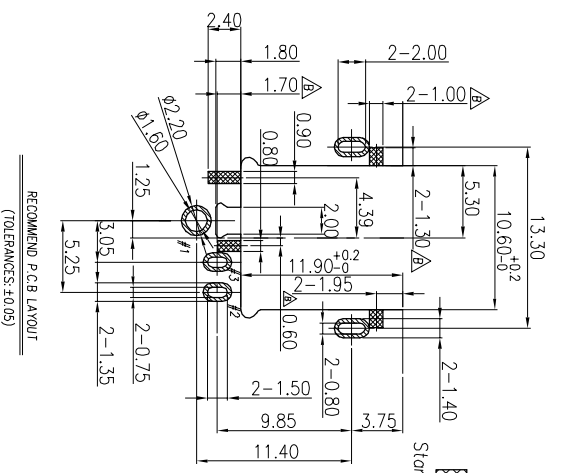
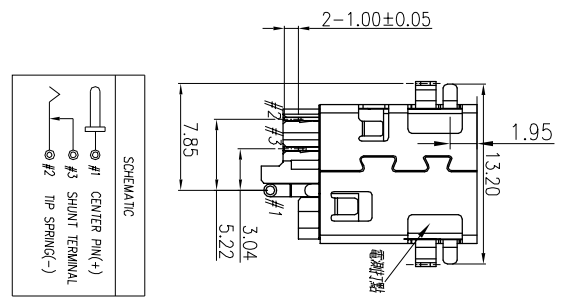
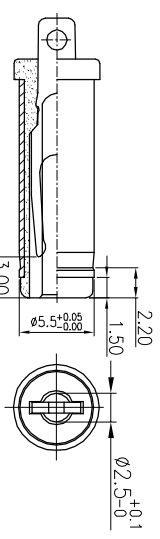
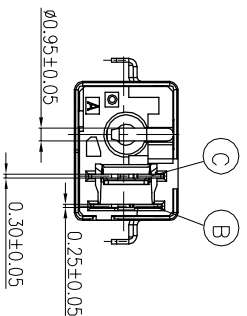
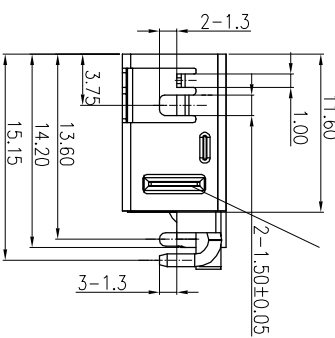
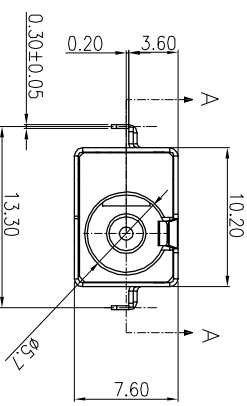
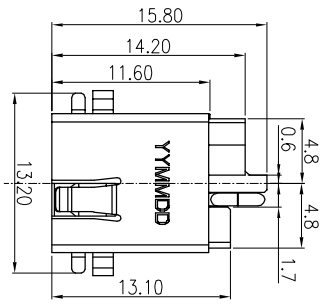
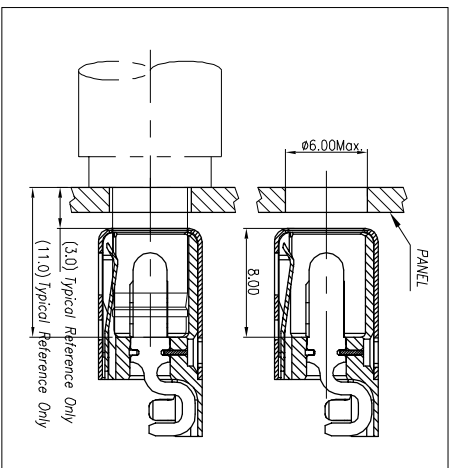

NO	DESCRIPTION	QTY	MATERIAL	PLATING & COLOR
F	TERMINAL	1	STAINLESS STEEL	N/A
E	SHELL	1	COPPER ALLOY	Ni 60u"
D	CENTER PIN	1	BRASS	GOLD FLASH OVER Ni 50u"
C	SHUNT TERMINAL	1	BRASS STRIP	GOLD FLASH ON CONTACT AREA 200u" Sn ON SOLDER TAIL ALL OVER Ni 50u" MIN.
B	TIP SPRING	1	COPPER ALLOY	BLACK
A	BODY	1	HIGH TEMP. THERMOPLASTIC U994V-0	BLACK

UNLESS OTHERWISE SPECIFIED TOLERANCES

Singatron Enterprise Co., Ltd.
信音企業股份有限公司

DECIMALS:	ANGLES:	TITLE	PART NO.	UNIT:	SCALE:	SHEET:	REVY:
X : ±0.5	X : ±2°	DWN	Qzhen	mm	4:1	10F2	B
X.X : ±0.3	X.X : ±1°	CHKD					
X.XX : ±0.2		APVD					

CUSTOMER COPY

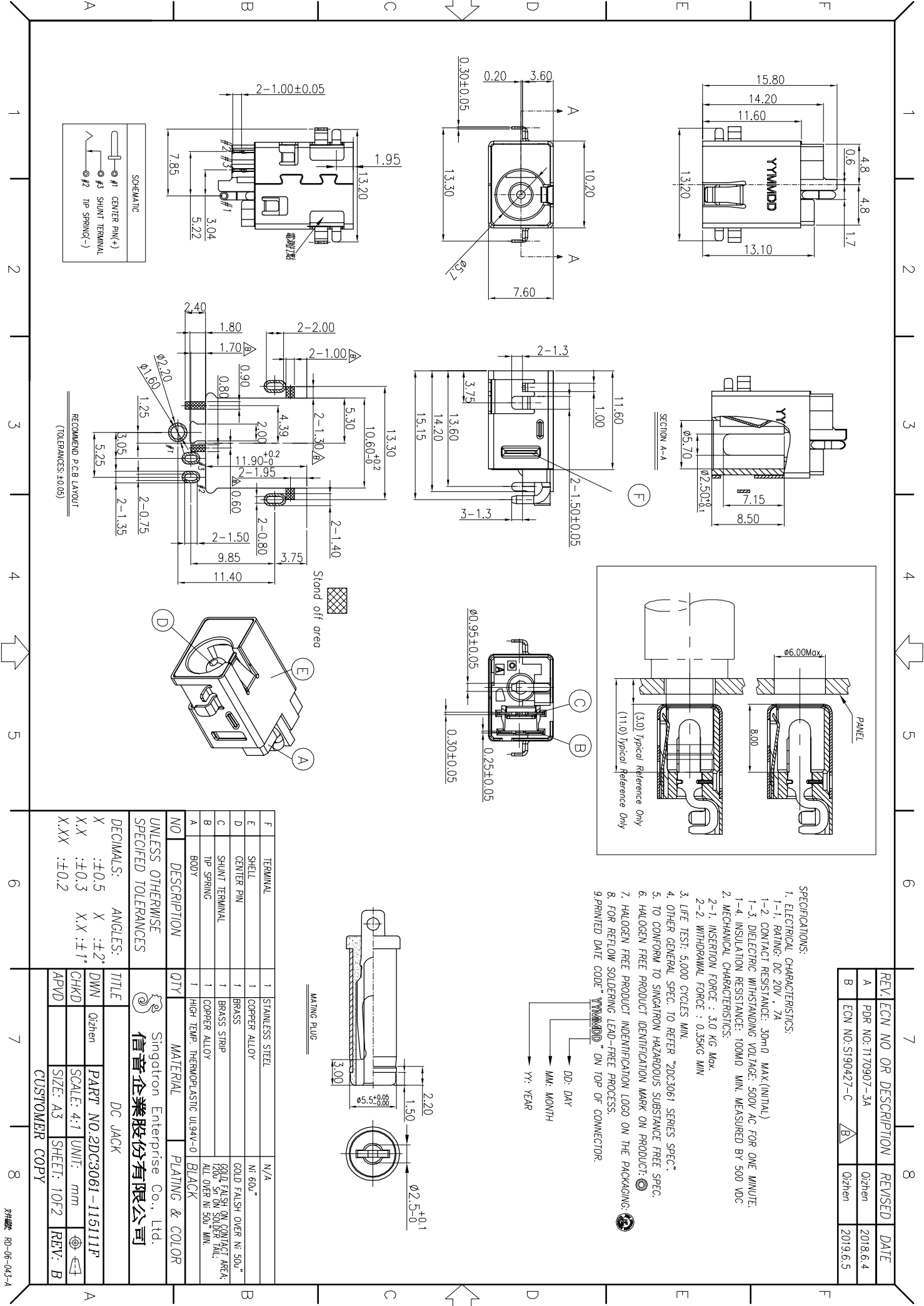

ZDC3061-115111F MATING DRAWING

3 LOCK POSITION

(0.35) Safety gap
(8.05)

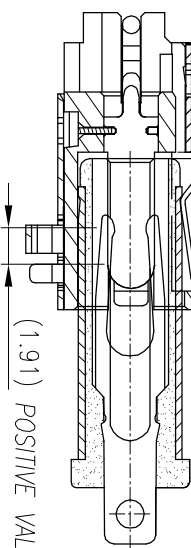
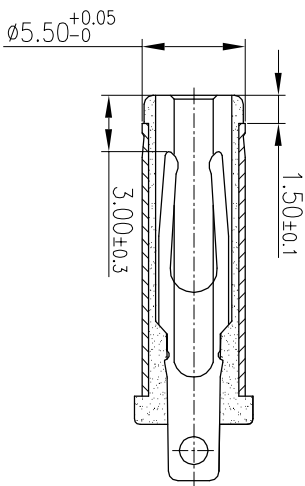

(1.91) POSITIVE VALID DISTANCE

1 NEGATIVE FIRST

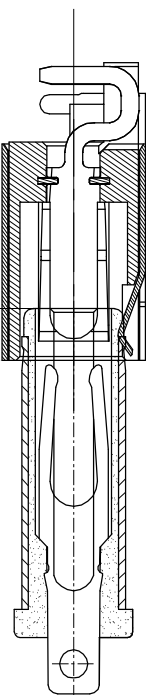

(2.74)

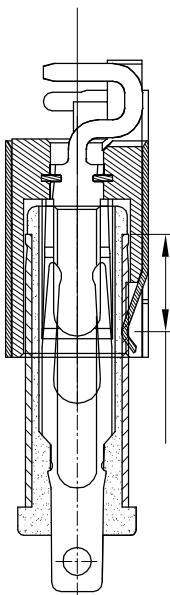

(5.20) NEGATIVE VALID DISTANCE

2 POSITIVE SECOND

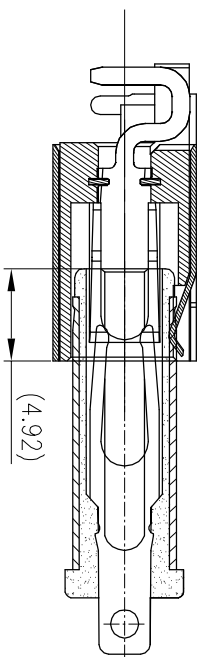

(4.92)

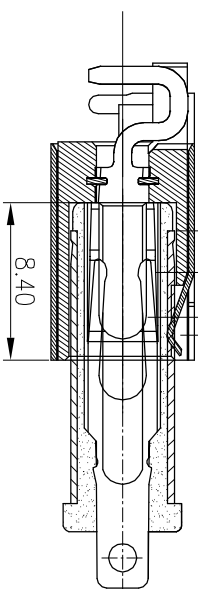

(5.55) NEGATIVE WORK DISTANCE
(2.38) POSITIVE WORK DISTANCE

4 PLUG WAS INSERTED INTO DC JACK TOTALLY

REV	ECN NO	OR DESCRIPTION	REVISED	DATE
A	PDR NO: T170907-3A		Qizhen	2018.6.4
B	ECN NO: S190427-C		Qizhen	2019.6.5

NO	DESCRIPTION	QTY	MATERIAL	PLATING & COLOR
UNLESS OTHERWISE SPECIFIED TOLERANCES				
信晉企業股份有限公司 Singatron Enterprise Co., Ltd.				
TITLE: DC JACK MATING				
DWN	Qizhen	PART NO: ZDC3061-115111F	SCALE: 4:1	UNIT: mm
CHKD		SIZE: A3	SHEET: 20F2	REV: B
APVD		CUSTOMER COPY		

A

B

C

D

E

F

1

2

3

4

5

6

7

8