

1

2

3

4

5

6

7

8

REV.	ECN NO OR DESCRIPTION	REVISED	DATE
A	PDR NO.:T210312-2A	Xuehua	2021.8.3
B	ECN NO.:S202111-C01/B	Kesheng	2022.4.27

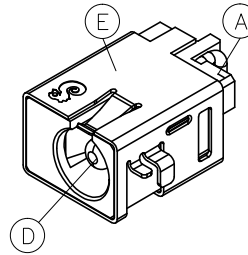
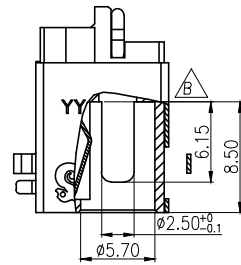
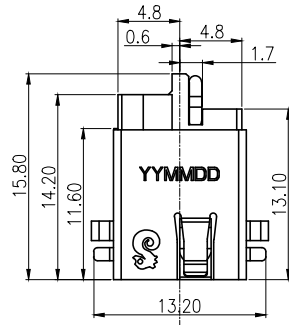

SPECIFICATIONS:

- ELECTRICAL CHARACTERISTICS:
 - RATING: DC 20V , 12A
 - CONTACT RESISTANCE: 30MΩ MAX.(INITIAL)
 - DIELECTRIC WITHSTANDING VOLTAGE: 500V AC FOR ONE MINUTE.
 - INSULATION RESISTANCE: 100MΩ MIN. MEASURED BY 500V DC.
- MECHANICAL CHARACTERISTICS:
 - INSERTION FORCE : 3.0 KG MAX.
 - WITHDRAWAL FORCE : 0.35KG MIN
- TEMPERATURE RISE CAN'T EXCEED 30°C.
- LIFE TEST: 5,000 CYCLES MIN.
- OTHER GENERAL SPEC. TO REFER "2DC3061-145111F".
- TO CONFORM TO SINGATRON HAZARDOUS SUBSTANCE FREE SPEC.
- HALOGEN FREE PRODUCT IDENTIFICATION MARK ON PRODUCT:
- HALOGEN FREE PRODUCT IDENTIFICATION LOGO ON THE PACKAGING:
- FOR REFLOW SOLDERING LEAD-FREE PROCESS.
- PRINTED DATE CODE "YYMDD" ON TOP OF JACK.

DD: DAY
MM: MONTH
YY: YEAR

11.THE PANEL'S ID MUST BE GREATER THAN THE PLUG'S OD WHICH MUST HAVE A DIFFERENCE OF LESS THAN OR EQUAL TO 0.5 mm.(AS SHOWN IN FIGURE 1.)

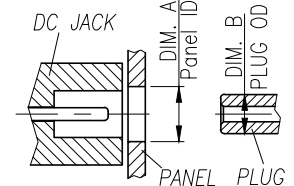
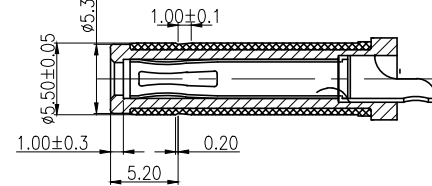
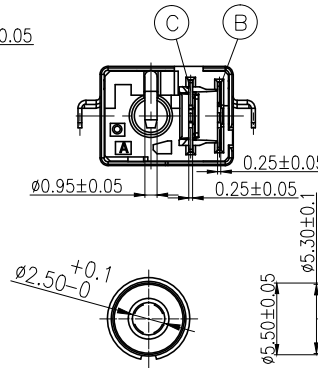
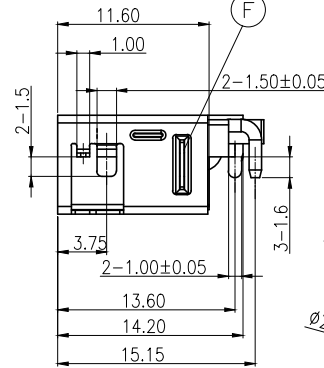
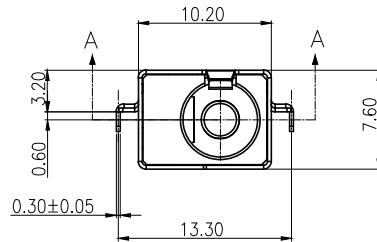

MATING PLUG (TOLERANCE:±0.05)
P/N: 5525TV0250-1T00-02

DIM. A-DIM.B ≤ 0.5
FIGURE 1

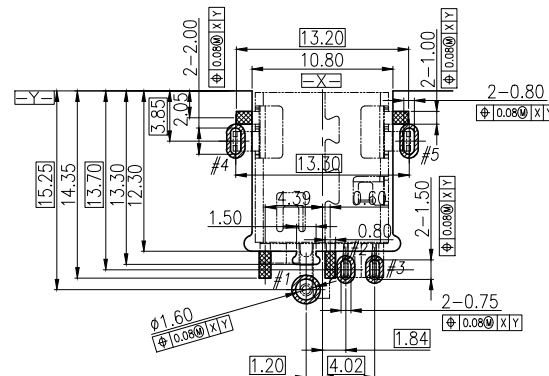
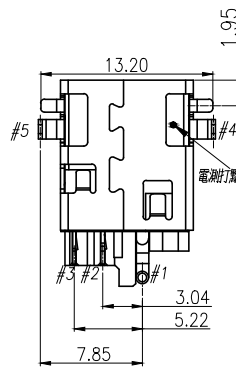

RECOMMEND P.C.B LAYOUT
TOP VIEW (TOLERANCES:±0.05)

STAND OFF AREA
 SOLDER PAD

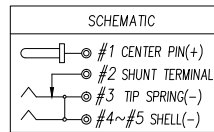

F	TERMINAL	1	STAINLESS STEEL	N/A
E	SHELL	1	COPPER ALLOY	Ni 60u"
D	CENTER PIN	1	BRASS	Au 30u" OVER Ni 50u".
C	SHUNT TERMINAL	1	BRASS STRIP	COLD FALSH ON CONTACT AREA; MATTIE Sn 120u" ON SOLDER TAIL; ALL OVER Ni 50u" MIN.
B	TIP SPRING	1	COPPER ALLOY	Au 30 u" ON CONTACT AREA ; MATTIE Sn 120u" ON SOLDER TAIL ; ALL OVER Ni 60u".
A	BODY	1	HIGH TEMP. THERMOPLASTIC	BLACK
NO	DESCRIPTION	QTY	MATERIAL	PLATING & COLOR

UNLESS OTHERWISE SPECIFIED TOLERANCES		Singatron Enterprise Co., Ltd. 信音企業股份有限公司	
DECIMALS:	ANGLES:	TITLE	
X :±0.5	X :±2°	DWN	Kesheng
X.X :±0.3	X.X :±1°	CHKD	Lussen
X.XX :±0.2		APVD	Liao
		SCALE: 4:1	
		UNIT: mm	
		SIZE: A3	
		SHEET:1 OF 2	
		REV:B	
CUSTOMER COPY			

REV.	ECN NO OR DESCRIPTION	REVISED	DATE
A	PDR NO.: T210312-2A	Xuehua	2021.8.3
B	ECN NO.: S202111-C01	Kesheng	2022.4.27

1 NEGATIVE FIRST

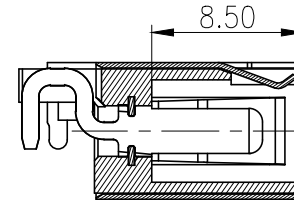
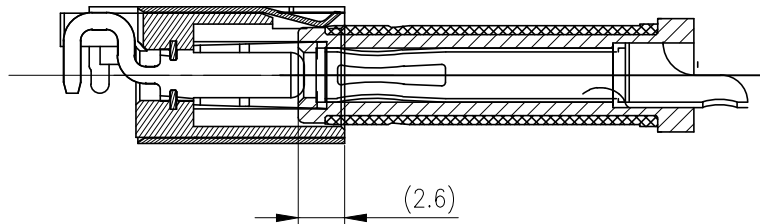

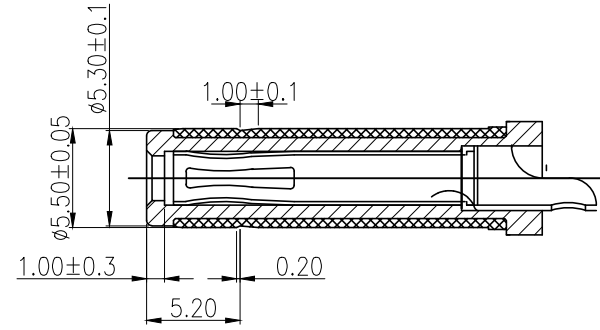
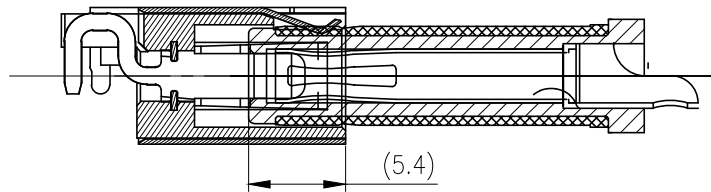

2 POSITIVE SECOND

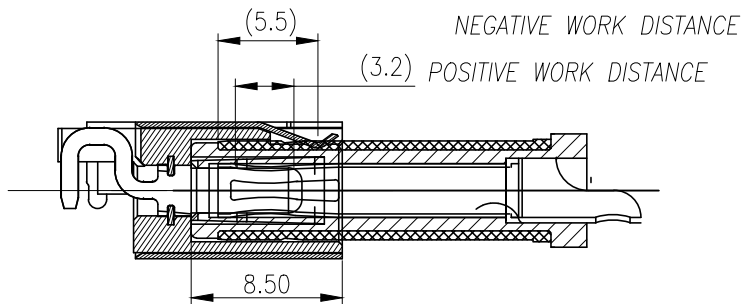

MATING PLUG (TOLERANCE:±0.05)
P/N: 5525TV0250-1T00-02

3 PLUG WAS INSERTED INTO DC JACK TOTALLY



NO	DESCRIPTION	QTY	MATERIAL	PLATING & COLOR
UNLESS OTHERWISE SPECIFIED TOLERANCES		 Singatron Enterprise Co., Ltd. 信音企業股份有限公司		
DECIMALS: X :±0.5 X.X :±0.3 X.XX :±0.2		ANGLES: X :±2° X.X :±1°		TITLE DC JACK MATING
		DWN	Kesheng	PART NO.2DC3061-145111F
		CHKD	Lussen	SCALE: 4:1 UNIT: mm
		APVD	Liao	SIZE: A3 SHEET:2 OF 2 REV:B
CUSTOMER COPY				