

MATING PLUG (料号: 401213P0225-5M00-02)
TOLERANCE: XXX:0.10

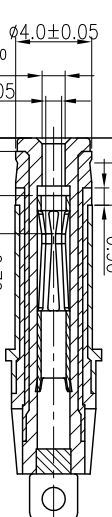

FIGURE 1

11. THE PANEL'S ID MUST BE GREATER THAN THE PLUG'S OD WHICH MUST HAVE A DIFFERENCE OF LESS THAN OR EQUAL TO 0.5 mm (AS SHOWN IN FIGURE 1.)
- DC JACK DIM. A DIM. B < 0.5
- PLUG DIM. A DIM. B
- YY: YEAR MM: MONTH DD: DAY
1. SPECIFICATIONS:
- Electrical Spec:
 - Rated Current: 5.5A
 - Rated Voltage: 20V
 - Insulation Resistance: 100MΩ MIN. After By 500 VDC for 1 minute
 - Dielectric Withstanding Voltage: 500V AC for 1 minute.
 - Contact Resistance: 50mΩ Max.
 - Mechanical Spec:
 - Insertion Force: 1.0~2.5 kg.(Initial) 0.8~2.3 kg.(After Life Test)
 - Withdrawal Force : 0.8~2.0kg.(Initial) 0.6~2.0kg.(After Life Test)
 - Temperature Rise Can't Exceed 30°
 - Weight: 895mg.
 - Life Test(Insertion/Withdrawal): 5,000 Cycles Min.
 - To Conform To SINGATRON Hazardous Substance Free Spec.
 - Halogen Free Product Identification Mark On Jack:
 - Halogen Free Product Identification Label On Packaging:
 - For Reflow Soldering Lead-Free Process.
 - Printed Date Code "YYMMDD" on top of connector.

ITEM	DESCRIPTION	QTY	MATERIAL	PLATING & COLOR
A	BODY	1	COPPER ALLOY	BLACK
B	PIN(+)	1	HIGH TEMP. THERMOPLASTIC US94V-0	BLACK
C	TERMINAL	1	STAINLESS STEEL 0.30T	N/A
D	SPRING(-)	1	COPPER ALLOY 0.20T	Ni 60U"
E	SHELL	1	STAINLESS STEEL 0.20T	Ni 60U"
F	SIGNAL LEFT	1	COPPER ALLOY 0.20T	SN 80U"Min, OVER Ni 50U"Min.
G	SIGNAL RIGHT	1	COPPER ALLOY 0.20T	SN 80U"Min, OVER Ni 50U"Min.

UNLESS OTHERWISE SPECIFIED TOLERANCES

DECIMALS: ANGLES:

X : ±0.5 X : ±2°

X.X : ±0.3 X.X : ±1°

X.XX : ±0.2

TITLE: DC POWER JACK

DWN: Yang

CHKD: Sky

APVD: Lussen

PART NO. 2DC3064-029111F

SCALE 4:1 UNIT: mm

SIZE: A3 SHEET: 1 OF 2 REV: A

Singatron Enterprise Co., Ltd.
信營企業股份有限公司

CUSTOMER COPY

REV.	ECN NO. OR DESCRIPTION	REVISED	DATE
A	PDR NO. TT31206-1A	Yang	2014.04.09

REV.	ECN NO OR DESCRIPTION	REVISED	DATE
A	PDR NO.T131206-1A	Yang	2014.04.09

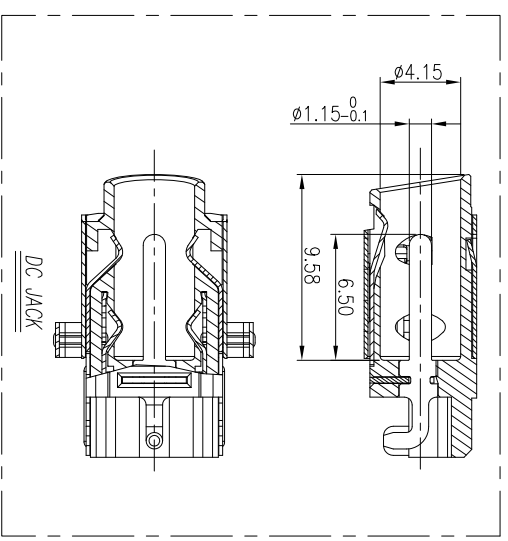
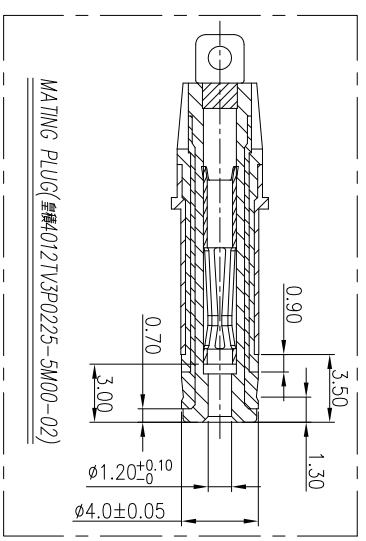
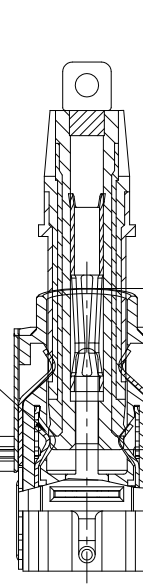
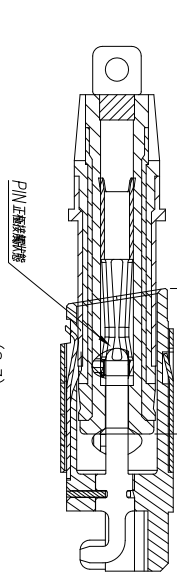
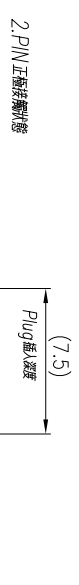
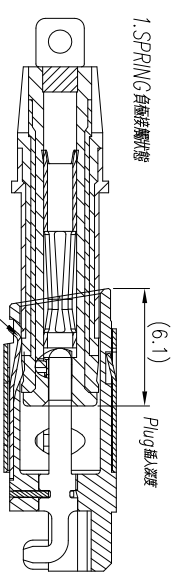

ITEM	DESCRIPTION	QTY	MATERIAL	PLATING & COLOR
UNLESS OTHERWISE SPECIFIED TOLERANCES				
DECIMALS: ANGLES:				
X	: ± 0.5	X	: $\pm 2^\circ$	
X.X	: ± 0.3	X.X	: $\pm 1^\circ$	
X.XX	: ± 0.2			
TITLE	DC POWER JACK MATING DRAWING			
DWN	Yang	PART NO.	2DC3064-029111F	
CHKD	Sky	SCALE	4:1	
APVD	Lussen	SIZE	A3	
		SHEET	2 OF 2	
		REV	A	

CUSTOMER COPY