

REV.	ECN NO OR DESCRIPTION	REVISED	DATE
A	PDR NO.T150914-3A	Jun	2015.12.03
B	ECN NO.S151259-R	Ron	2016.02.15
C	ECN NO.S160160-E	Ken	2016.03.22

SPECIFICATIONS:

- ELECTRICAL CHARACTERISTICS:
  - RATING: 20V 4A
  - CONTACT RESISTANCE: 30mΩ MAX.
  - DIELECTRIC WITHSTANDING VOLTAGE: 500V AC FOR ONE MINUTE.
  - INSULATION RESISTANCE: 100MΩ MIN. MEASURED BY 500 VDC
- MECHANICAL CHARACTERISTICS:
  - INSERTION FORCE: 2.0 Kgf Max.
  - WITHDRAWAL FORCE: INITIAL:MATING/UN-MATING:0.7~2.0 Kgf. AFTER 15K CYCLES :MATING/UN-MATING:0.5~2.0 Kgf.
- LIFE TEST: 15000 CYCLES.
- TO CONFORM TO SINGATRON HAZARDOUS SUBSTANCE FREE SPEC.
- HALOGEN FREE PRODUCT IDENTIFICATION MARK ON JACK:
- HALOGEN FREE PRODUCT IDENTIFICATION LABEL ON PACKAGING:
- FOR HAND SOLDERING LEAD-FREE PROCESS.
- PRINTED DATE CODE "YYMMDD".

DD: DAY  
MM: MONTH  
YY: YEAR

9.THE PANEL'S ID MUST BE GREATER THAN THE PLUG'S OD WHICH MUST HAVE A DIFFERENCE OF LESS THAN OR EQUAL TO 0.5 mm.(AS SHOWN IN FIGURE 1.)

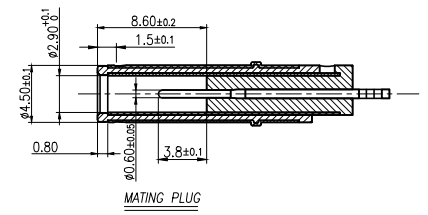
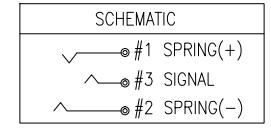
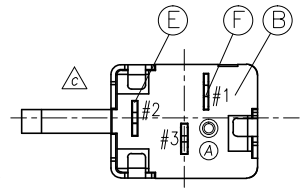
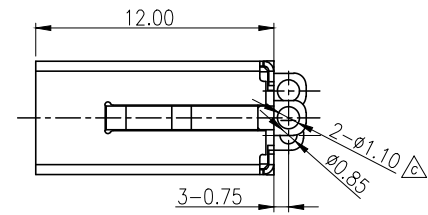
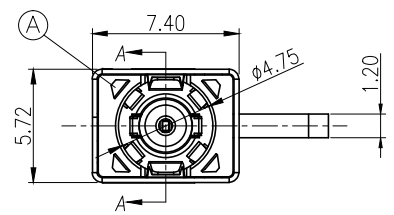
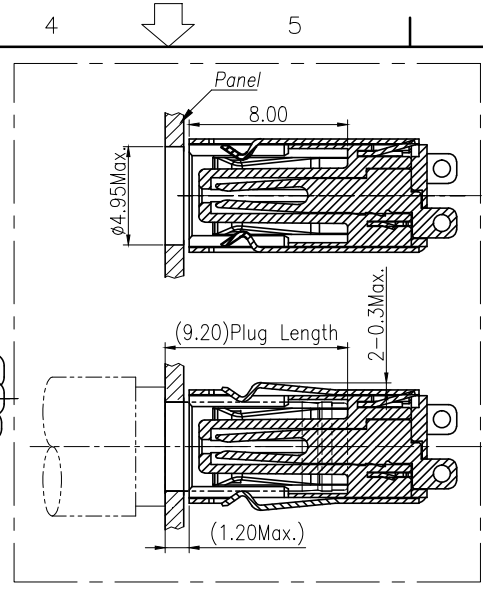
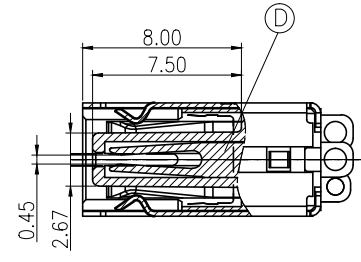
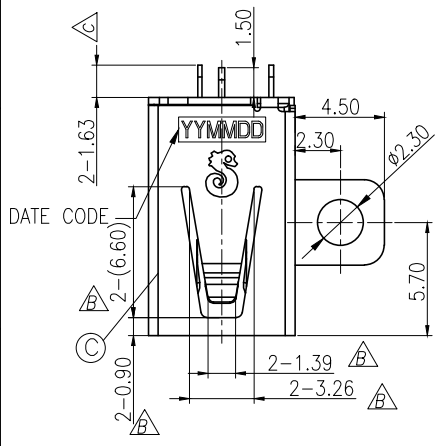

PLUG 规格 45P06CV230-1A00-01

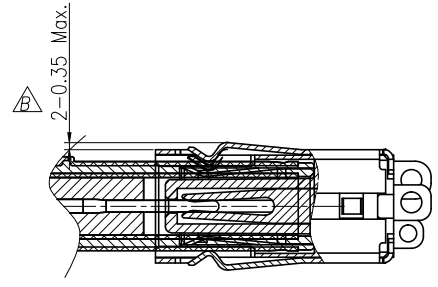

SECTION A-A  
PLUG IN

NO	DESCRIPTION	QTY	MATERIAL	PLATING & COLOR
F	SPRING(+)	1	COPPER ALLOY 0.20T	Gold Flash On Contact Area. Sn 120u"Min On Solder Tail. All Over Ni 50u"Min.
E	SPRING(-)	1	COPPER ALLOY 0.20T	
D	SIGNAL	1	COPPER ALLOY 0.20T	Ni 50u"Min.
C	SHELL	1	STAINLESS STEEL 0.25T	
B	COVER	1	HIGH TEMP.THERMOPLASTIC (HALOGEN FREE)UL 94V-0	BLACK
A	BODY	1	PA6T UL 94V-0	BLACK

UNLESS OTHERWISE SPECIFIED TOLERANCES		Singatron Enterprise Co., Ltd. 信音企業股份有限公司	
DECIMALS:	ANGLES:	TITLE: DC POWER JACK	
X :±0.5	X :±2°	DWN	Ken PART NO. 2DC3069-011114F
X.X :±0.3	X.X :±1°	CHKD	cerry SCALE 4:1 UNIT: mm
X.XX :±0.2		APVD	lussen SIZE: A3 SHEET:1 OF 2 REV:C
CUSTOMER COPY			

REV.	ECN NO OR DESCRIPTION	REVISED	DATE
A	PDR NO:T150914-3A	Jun	2015.12.03
B	ECN NO:S151259-R	Ron	2016.02.15
C	ECN NO.S160160-E $\triangle$	Ken	2016.03.22

<1.>負極先接觸狀態

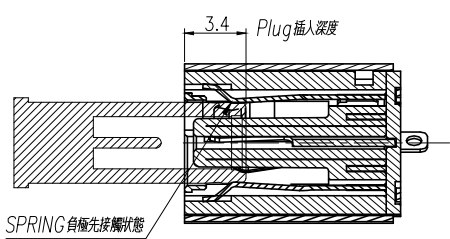

<2.>正極接觸狀態

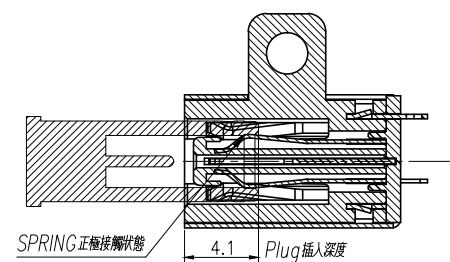

<3.>Signal 接觸狀態

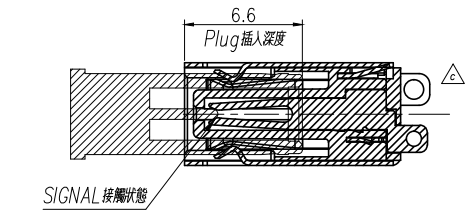

<4.>Plug full Mating狀態

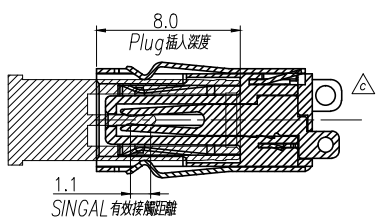
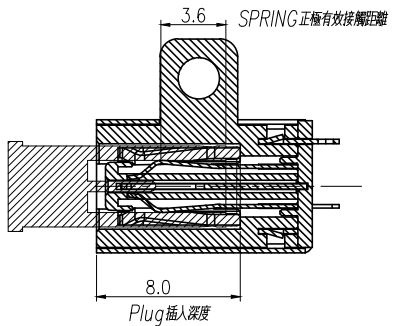
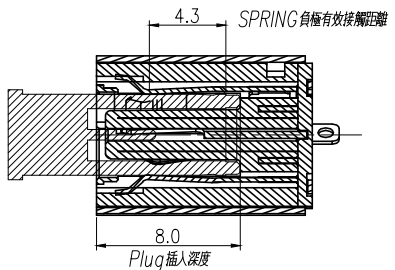

NO	DESCRIPTION	QTY	MATERIAL	PLATING & COLOR
UNLESS OTHERWISE SPECIFIED TOLERANCES		Singatron Enterprise Co., Ltd. 信音企業股份有限公司		
DECIMALS: X :±0.5 X.X :±0.3 X.XX :±0.2		ANGLES: X :±2° X.X :±1°		TITLE DC JACK MATING
DWN	Ken	PART NO.2DC3069-01114F		
CHKD	cerry	SCALE: 4:1	UNIT: mm	$\oplus$ $\triangleleft$
APVD	lussen	SIZE: A3	SHEET: 20F2	REV:C
CUSTOMER COPY				