

REV.	ECN NO OR DESCRIPTION	REVISED	DATE
A	PDR NO.:T220817-1A	Jie	2023.8.21

- SPECIFICATIONS:
- ELECTRICAL CHARACTERISTICS:
    - RATING: 20V 5A.
    - CONTACT RESISTANCE: 30mΩ MAX.
    - DIELECTRIC WITHSTANDING VOLTAGE: 500V AC FOR ONE MINUTE.
    - INSULATION RESISTANCE: 100MΩ MIN. MEASURED BY 500 VDC
  - MECHANICAL CHARACTERISTICS:
    - INSERTION FORCE: 2.5Kgf Max.
    - WITHDRAWAL FORCE: INITIAL 0.8Kgf MIN.; AFTER LIFE TEST: 0.6Kgf MIN.
  - TEMPERATURE RISE CAN'T EXCEED 30°C.
  - LIFE TEST: 5,000 CYCLES.
  - WEIGHT: 1.17g.
  - TO CONFORM TO SINGATRON HAZARDOUS SUBSTANCE FREE SPEC.
  - OTHER GENERAL SPEC, PLEASE REFER TO "2DC3069-038114F SPEC".
  - HALOGEN FREE IDENTIFICATION MARK ON JACK:
  - HALOGEN FREE IDENTIFICATION LABEL ON PACKAGING:
  - FOR HAND SOLDERING LEAD-FREE PROCESS.

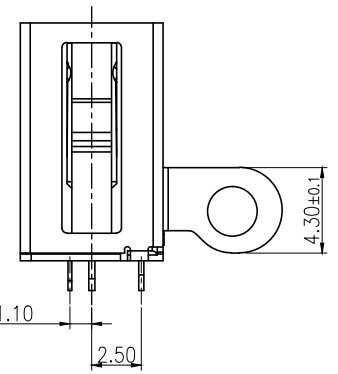
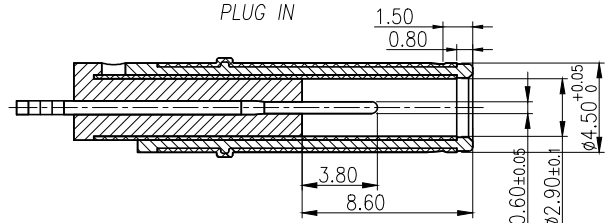
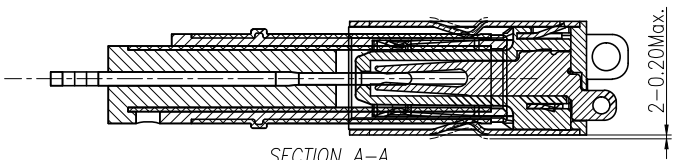
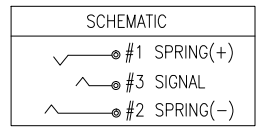
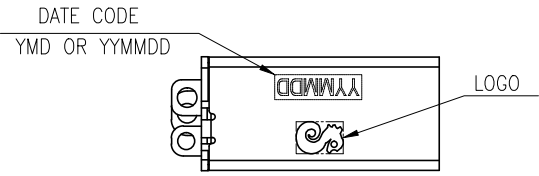
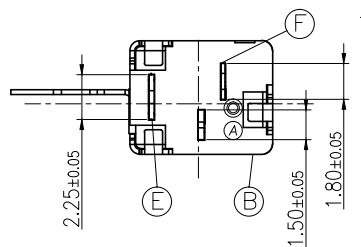
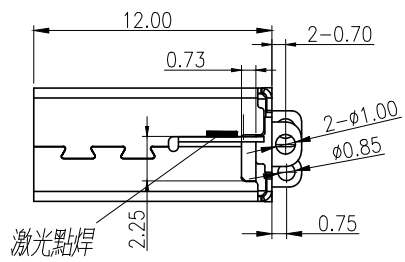
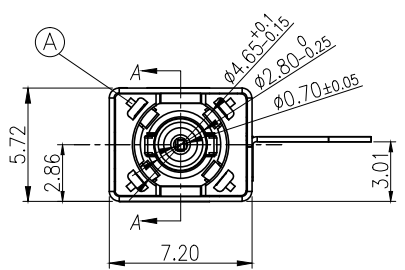
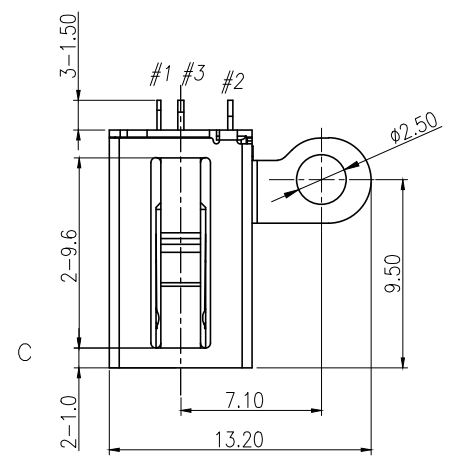
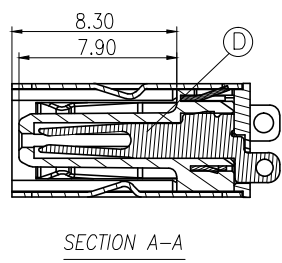
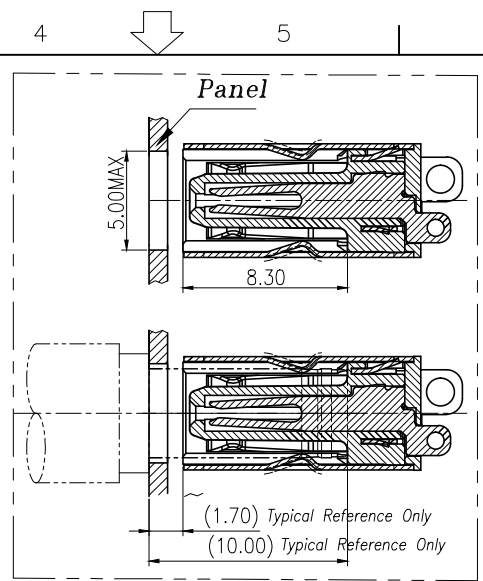

F	SPRING(+)	1	COPPER ALLOY 0.20T	Au30" or Au5u" And 25u" Pd/Ni on contact
E	SPRING(-)	1	COPPER ALLOY 0.25T	Matte Sn 120u"Min On Solder;
D	SIGNAL	1	PHOSPHOR BRONZE 0.30T	All Over Ni 50u"Min.
C	SHELL	1	STAINLESS STEEL 0.25T	Ni 50u"Min.
B	COVER	1	THERMOPLASTIC UL 94V-0 (HALOGEN FREE)	BLACK
A	BODY	1		
NO	DESCRIPTION	QTY	MATERIAL	PLATING & COLOR

UNLESS OTHERWISE SPECIFIED TOLERANCES		Singatron Enterprise Co., Ltd. 信音企業股份有限公司	
DECIMALS:	ANGLES:	TITLE: DC POWER JACK	
X :±0.5	X :±2°	DWN	Jie PART NO. 2DC3069-038114F
X.X :±0.3	X.X :±1°	CHKD	Lussen SCALE 4:1 UNIT: mm
X.XX :±0.2		APVD	Liao SIZE: A3 SHEET: 1 OF 2 REV: A
<b>CUSTOMER COPY</b>			

MATING PLUG(FUAN GEE:45P06CV230-1A00-01)  
TOLERANCE:X.XX:±0.10

REV.	ECN NO OR DESCRIPTION	REVISED	DATE
A	PDR NO.:T220817-1A	Jie	2023.8.21

1. SPRING 負極接觸狀態

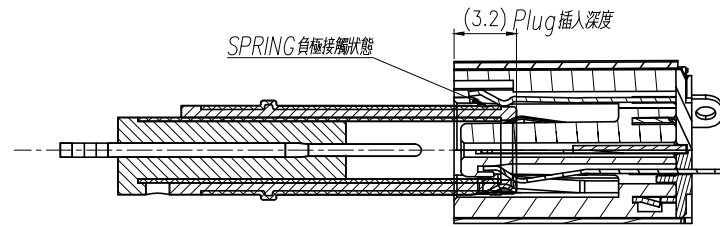

4. Lock 狀態

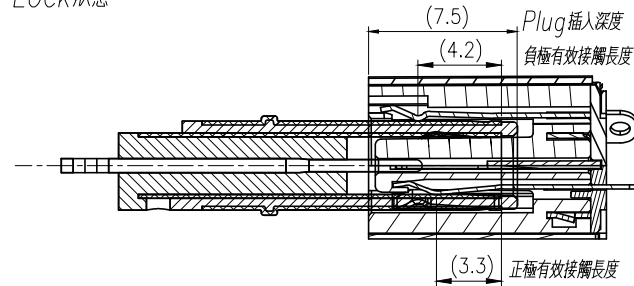

2. SPRING 正極接觸狀態

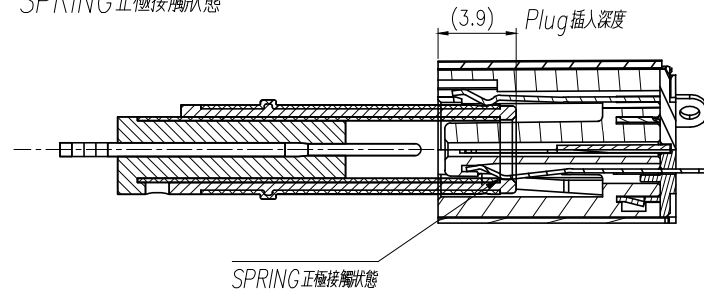

5. Plug 插到底狀態

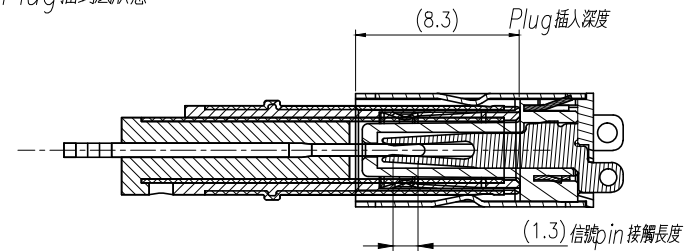

3. SIGNAL PIN 接觸狀態

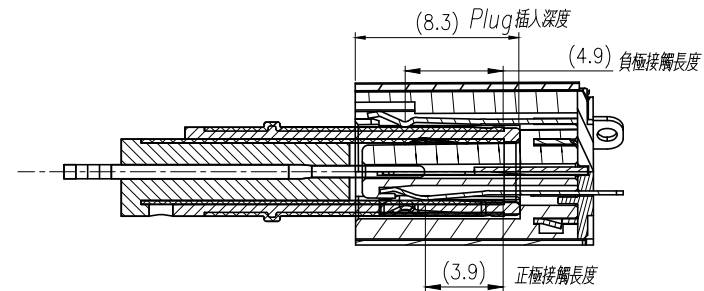
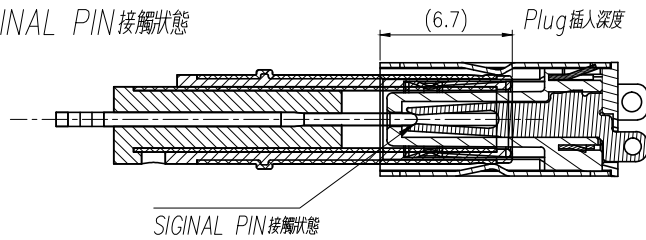

4. Lock 狀態

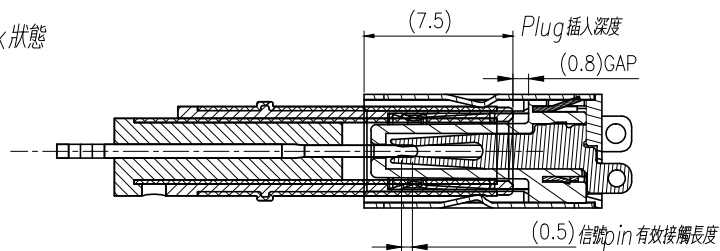

ITEM	DESCRIPTION	QTY	MATERIAL	PLATING & COLOR
UNLESS OTHERWISE SPECIFIED TOLERANCES		Singatron Enterprise Co., Ltd. 信音企業股份有限公司		
DECIMALS: ANGLES:		TITLE: DC POWER JACK_MATING DRAWING		
X	:±0.5 X :±2°	DWN	Jie	PART NO. 2DC3069-038114F
X.X	:±0.3 X.X :±1°	CHKD	Lussen	SCALE 4:1 UNIT: mm
X.XX	:±0.2	APVD	Liao	SIZE: A3 SHEET:2 OF 2 REV: A
CUSTOMER COPY				