

REV.	ECN NO OR DESCRIPTION	REVISED	DATE
A	PDR NO.T140522-3A	Ron	2014.09.28
B	ECN NO.S141053	Ken	2014.11.27
C	ECN NO.S151112-C	YUREN	2015.12.21
D	ECN NO.S160610-C	YUREN	2016.07.29

- SPECIFICATIONS:
- Electrical Spec:
 - Rated Current: 7A
 - Rated Voltage: 20V
 - Insulation Resistance: 100MΩ MIN. After By 500 VDC for 1 minute
 - Dielectric Withstanding Voltage: 500V AC for 1 minute.
 - Contact Resistance: 15mΩ Max.
 - Mechanical Spec:
 - Insertion Force: 0.8~2.0Kgf(Initial and After Life Test).
 - Withdrawal Force : 0.8~2.0Kgf(Initial and After Life Test).
 - Weight: 0.95 gram.
 - Temperature rise can't exceed 30 °C MAX.
 - Life Test(Insertion/Withdrawal): 8,000 Cycles Min.
 - To Conform To SINGATRON Hazardous Substance Free Spec.
 - Other general SPEC, please refer to "2DC3071 SERIES SPEC".
 - Halogen Free Product Identification Mark On Jack:
 - Halogen Free Product Identification Label On Packaging:
 - For Reflow Soldering Lead-Free Process.
 - Printed Date Code"SYMMDD" on top of connector.

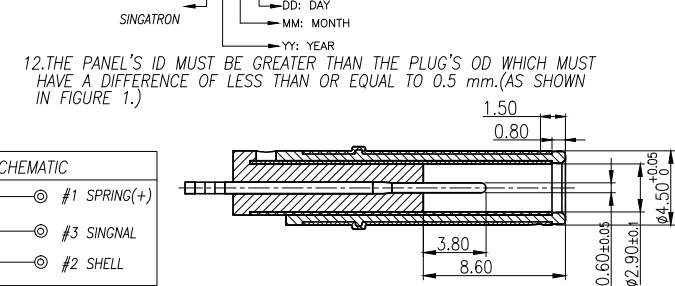

MATING PLUG(FUAN GEE:45P06CV230-1A00-01)
TOLERANCE:X.XX:±0.10

ITEM	DESCRIPTION	QTY	MATERIAL/THICK(mm)	FINISH
E	MYLAR	1	TRANSPARENT PT-83 0.075T	N/A
D	SIGNAL	1	PHOSPHOR BRONZE(C5210) 0.30T	GOLD-PLATED(5u" Min.)+Pd/Ni (25u" Min.) ON CONTACT AREA .
C	SPRING+	1	PHOSPHOR BRONZE(C5210) 0.20T	Sn 120u" Min ON SOLDER TAIL . ALL OVER Ni 50u" MIN.
B	SHELL	1	PHOSPHOR BRONZE(C5210) 0.20T	GOLD FLASH ON SOLDER TAIL; ALL OVER Ni 50u" MIN.
A	BODY	1	(PA4T+30%GF) UL94V-0	BLACK

UNLESS OTHERWISE SPECIFIED TOLERANCES		SINGATRON ENTERPRISE CO., LTD. 信音企業股份有限公司	
DECIMALS:	ANGLES:	TITLE	
X :±0.5	X :±2°	DWN	YUREN
X.X :±0.3	X.X :±1°	CHKD	CERRY
X.XX :±0.2		APVD	LIAO
		DC POWER JACK	
		PART NO. 2DC3071-009111F	
		SCALE 3:1 UNIT: mm	
		SIZE: A3 SHEET:1 OF 2	
		REV:D	

CUSTOMER COPY

REV.	ECN NO OR DESCRIPTION	REVISED	DATE
A	PDR NO.T140522-3A	Ron	2014.09.28
B	ECN NO.S141053	Ken	2014.11.27
C	ECN NO.S151112-C	YUREN	2015.12.21
D	ECN NO.S160610-C	YUREN	2016.07.29

1.NEGATIVE FIRST

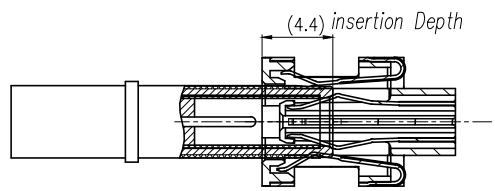

4.LOCK POSITION

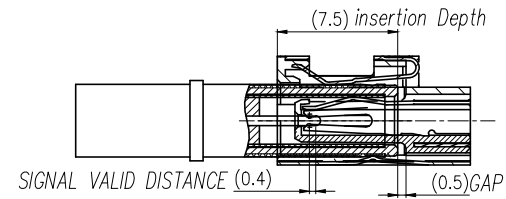

2.POSITIVE SECOND

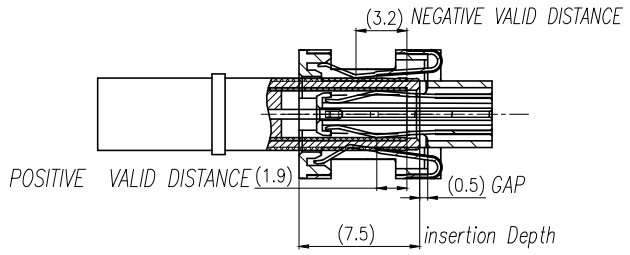
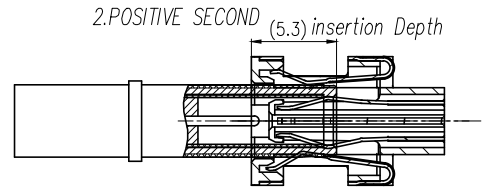

3.SIGNAL THIRD

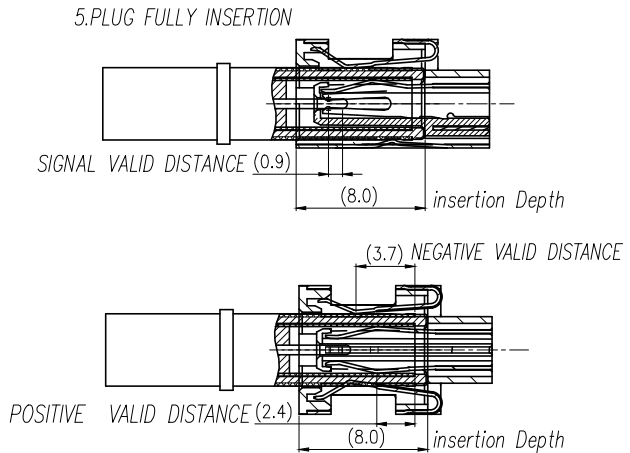
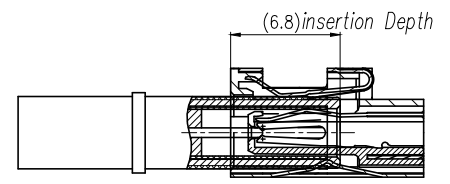

NO	DESCRIPTION	QTY	MATERIAL	PLATING & COLOR
UNLESS OTHERWISE SPECIFIED TOLERANCES		 Singatron Enterprise Co., Ltd. 信音企業股份有限公司		
DECIMALS:	ANGLES:	TITLE	MATING DRAWING	
X :±0.5	X :±2°	DWN	YUREN	PART NO. 2DC3071-009111F
X.X :±0.3	X.X :±1°	CHKD	CERRY	SCALE 4:1 UNIT: mm
X.XX :±0.2		APVD	LIAO	SIZE: A3 SHEET:2 OF 2 REV:D
CUSTOMER COPY				