

REV.	ECN NO OR DESCRIPTION	REVISED	DATE
C	ECN NO.S170538-R	YUREN	2017.8.29
D	ECN NO.S170940-R	YUREN	2017.12.29
E	ECN NO.S171208-C	YUREN	2018.3.23
F	ECN NO.S180403-C	△ BORU	2018.5.11

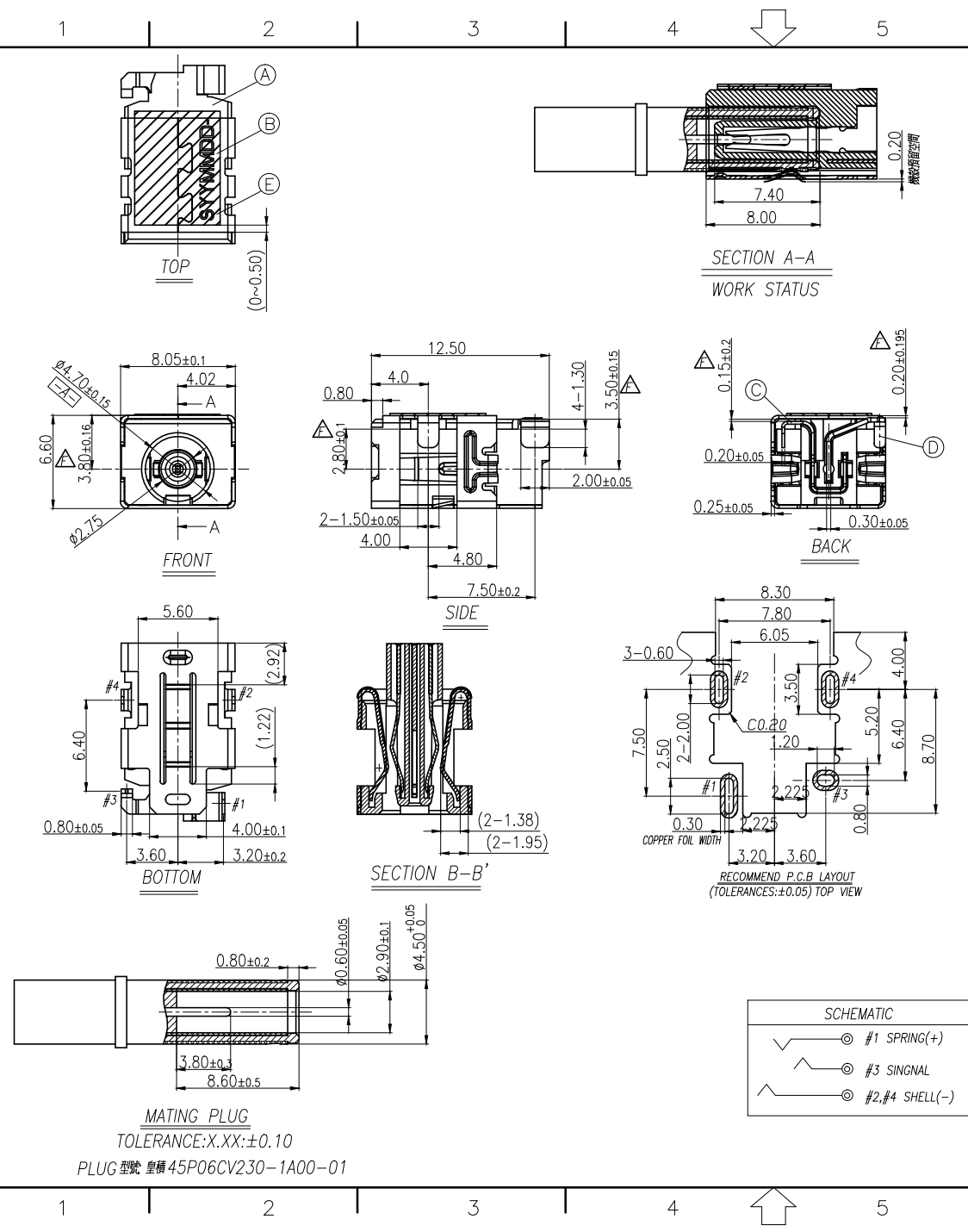

- SPECIFICATIONS:**
- ELECTRICAL CHARACTERISTICS:**
    - 1-1. RATING: 20V 6.5A
    - 1-2. CONTACT RESISTANCE: 30mΩ MAX.
    - 1-3. DIELECTRIC WITHSTANDING VOLTAGE: 500V AC FOR ONE MINUTE.
    - 1-4. INSULATION RESISTANCE: 100MΩ MIN. MEASURED BY 500 VDC
  - MECHANICAL CHARACTERISTICS:**
    - 2-1. INSERTION&WITHDRAWAL FORCE: 1.0~3.0 Kgf(INITIAL)
    - 2-2. NSERTION&WITHDRAWAL FORCE: 0.5~3.0 Kgf(AFTER TEST)
  - LIFE TEST: 5,000 CYCLES.**
  - TO CONFORM TO SINGATRON HAZARDOUS SUBSTANCE FREE SPEC.**
  - HALOGEN FREE PRODUCT IDENTIFICATION MARK ON PRODUCT: (C)**
  - HALOGEN FREE PRODUCT IDENTIFICATION LOGO ON PACKAGING: (C)**
  - FOR HAND SOLDERING LEAD-FREE PROCESS.**
  - PRINTED DATE CODE "YYMMDD".**
    - DD: DAY
    - MM: MONTH
    - YY: YEAR
9. THE PANEL'S ID MUST BE GREATER THAN THE PLUG'S OD WHICH MUST HAVE A DIFFERENCE OF LESS THAN OR EQUAL TO 0.5 mm.(AS SHOWN IN FIGURE 1.)

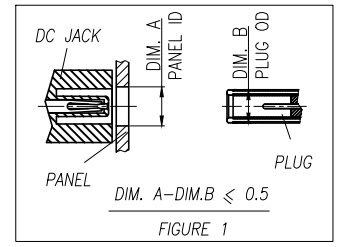

ITEM	DESCRIPTION	QTY	MATERIAL/THICK(mm)	FINISH
E	MYLAR	1	0.075T	YELLOW
D	SIGNAL	1	C5210 0.3T	Pd/Ni (30u" MIN.)&GOLD PLATED(5u"MIN.) ON CONTACT AREA; MATTE Sn 120u" MIN. ON SOLDER TAIL; ALL OVER Ni 50u" MIN.
C	SPRING+	1	C7035 0.2T	
B	SHELL	1	C5210 0.25T	GOLD FLASH ALL OVER ALL OVER Ni 50u" MIN.
A	BODY	1	PA4T+30%GF UL94V-0	BLACK
UNLESS OTHERWISE SPECIFIED TOLERANCES		Singatron Enterprise Co., Ltd. 信音企業股份有限公司		
DECIMALS: ANGLES:		TITLE: DC POWER JACK		
X	:±0.5	X	:±2'	DWN Boru
X.X	:±0.3	X.X	:±1'	CHKD Ron
X.XX	:±0.2	APVD Lussen		
		<b>PART NO. 2DC3071-026111F</b> SCALE 3:1 UNIT: mm SIZE: A3 SHEET:1 OF 2 <b>REV:F</b>		
<b>CUSTOMER COPY</b>				

REV.	ECN NO OR DESCRIPTION	REVISED	DATE
C	ECN NO.S170538-R	YUREN	2017.8.29
D	ECN NO.S170940-R	YUREN	2017.12.29
E	ECN NO.S171208-C	YUREN	2018.3.23
F	ECN NO.S180403-C	△ BORU	2018.5.11

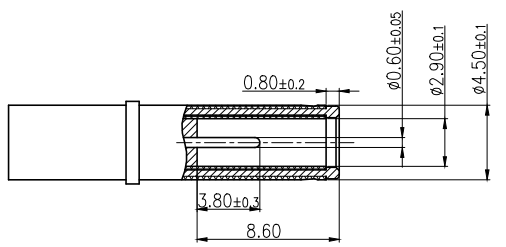
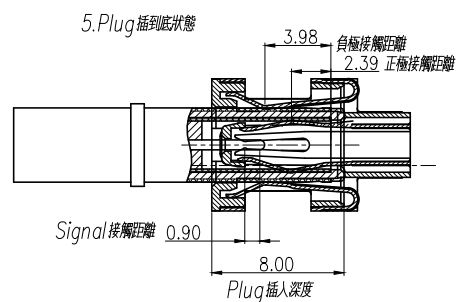
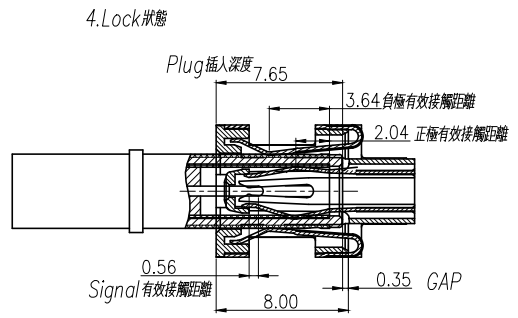
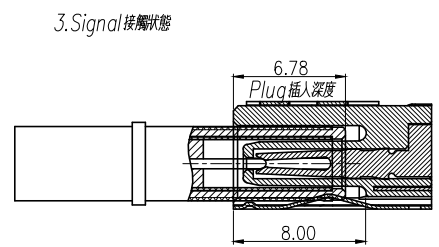
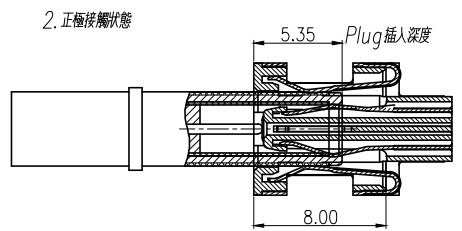
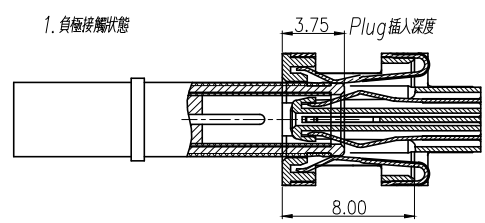

PLUG 型號 皇積 45P06CV230-1A00-01

ITEM	DESCRIPTION	QTY	MATERIAL/THICK(mm)	FINISH
UNLESS OTHERWISE SPECIFIED TOLERANCES		Singatron Enterprise Co., Ltd. 信音企業股份有限公司		
DECIMALS: X :±0.5 X.X :±0.3 X.XX :±0.2		ANGLES: X :±2° X.X :±1°		TITLE: MATING DWG DWN: Boru CHKD: Ron APVD: Lussen
		PART NO. 2DC3071-026111F		SCALE 3:1 UNIT: mm SIZE: A3 SHEET: 2 OF 2 REV: F
CUSTOMER COPY				