

REV.	ECN NO OR DESCRIPTION	REVISED	DATE
A	PDR NO.T160114-6A	Ron	2017.03.17
B	ECN NO.S170538-R	YUREN	2017.08.11

SPECIFICATIONS:

- ELECTRICAL SPEC:
 - 1-1. RATED CURRENT: 4.5A
 - 1-2. RATED VOLTAGE: 20V
 - 1-3. INSULATION RESISTANCE: 100MΩ MIN. AFTER BY 500 VDC FOR 1 MINUTE
 - 1-4. DIELECTRIC WITHSTANDING VOLTAGE: 500V AC FOR 1 MINUTE.
 - 1-5. CONTACT RESISTANCE: 30mΩ MAX.(INITIAL)
- MECHANICAL SPEC:
 - 2-1. INSERTION FORCE: 3.0Kgf MAX..
 - 2-2. WITHDRAWAL FORCE : 1.0~2.5Kg(Initial),0.4~2.5Kg(After life test).
- WEIGHT: 1.0 GRAM.
- TEMPERATURE RISE CAN'T EXCEED 30°C MAX.
- LIFE TEST(INSERTION/WITHDRAWAL): 5,000 CYCLES MIN.
- OTHER GENERAL SPEC, PLEASE REFER TO "2DC3071 SERIES SPEC".
- HALOGEN FREE PRODUCT IDENTIFICATION MARK ON JACK: ⊙
- HALOGEN FREE PRODUCT IDENTIFICATION LABEL ON PACKAGING: 
- FOR REFLOW SOLDERING LEAD-FREE PROCESS.
- THE PANEL'S ID MUST BE GREATER THAN THE PLUG'S OD WHICH MUST HAVE A DIFFERENCE OF LESS THAN OR EQUAL TO 0.50mm.(AS SHOWN IN FIGURE 1.)

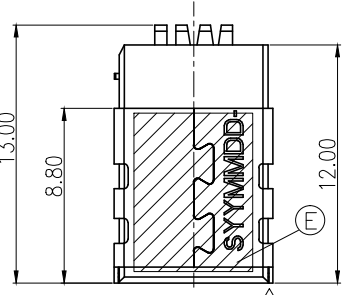
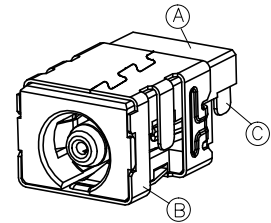
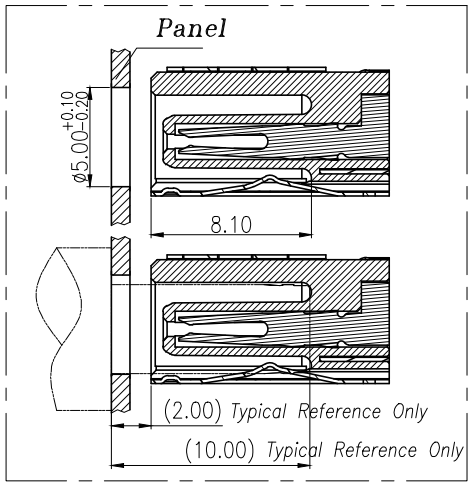

SINGATRON

SYMMDD

DD: DAY
MM: MONTH
YY: YEAR

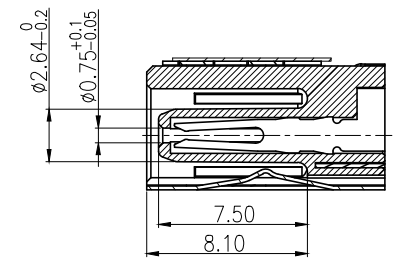
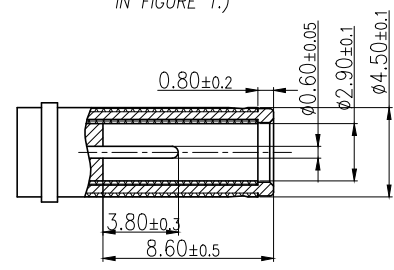
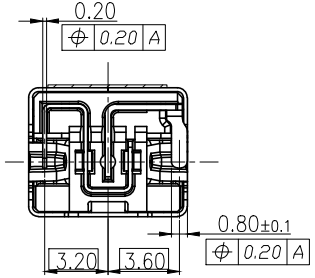
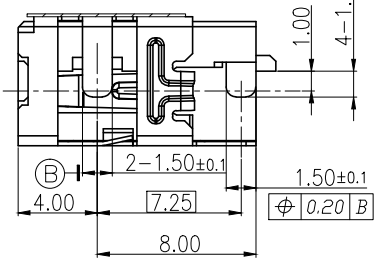
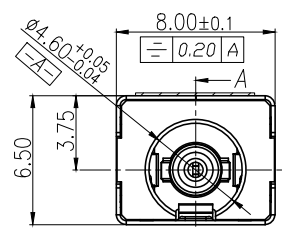

MATING PLUG
TOLERANCE:X.XX:±0.10

PLUG 型号 45P06CV230-1A00-01

ITEM	DESCRIPTION	QTY	MATERIAL/THICK(mm)	FINISH
E	MYLAR	1	MYLAR 0.075t	YELLOW
D	SIGNAL	1	C5210-EH 0.30T	Pd/Ni (30u" MIN.)&GOLD PLATED(5u" MIN.) ON CONTACT AREA; MATTE Sn 120u" MIN. ON SOLDER TAIL; ALL OVER Ni 50u" MIN.
C	SPRING+	1	C5210-EH 0.20T	
B	SHELL	1	C5210-H 0.20T	Ni 60u" Min.
A	BODY	1	PA4T+30%GF TITX1 UL 94V-0	BLACK

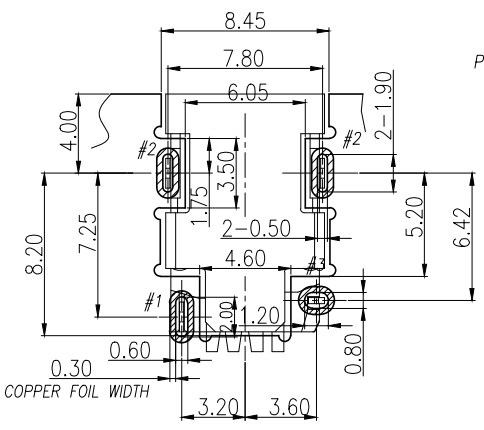
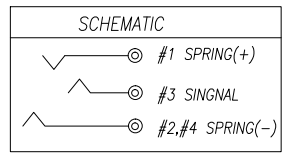

RECOMMEND P.C.B LAYOUT
(TOLERANCES:±0.05) TOP VIEW

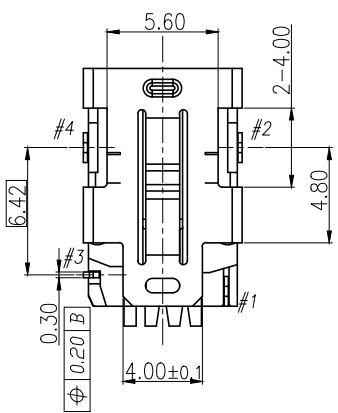

UNLESS OTHERWISE SPECIFIED TOLERANCES		 Singatron Enterprise Co., Ltd. 信音企業股份有限公司	
DECIMALS:	ANGLES:	TITLE: DC POWER JACK	
X :±0.5	X :±2°	DWN	YUREN PART NO. 2DC3071-030111F
X.X :±0.3	X.X :±1°	CHKD	CERRY SCALE 4:1 UNIT: mm
X.XX :±0.2		APVD	LIAO SIZE: A3 SHEET:1 OF 2 REV:B
CUSTOMER COPY			

REV.	ECN NO OR DESCRIPTION	REVISED	DATE
A	PDR NO.T160114-6A	Ron	2017.03.17
B	ECN NO.S170538-R	YUREN	2017.08.11

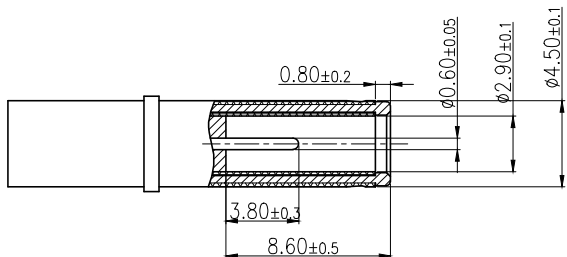
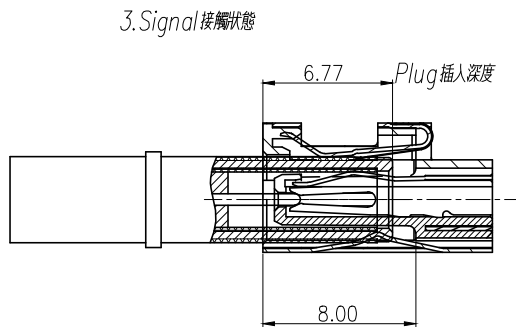
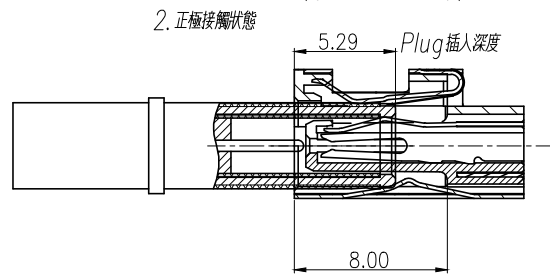
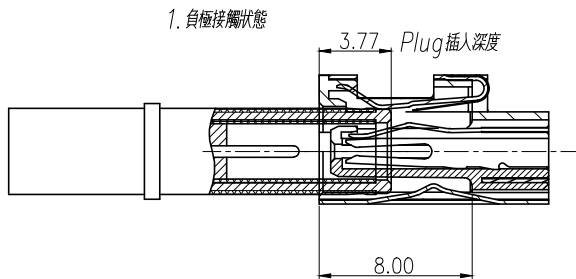

PLUG 型號 皇積 45P06CV230-1A00-01

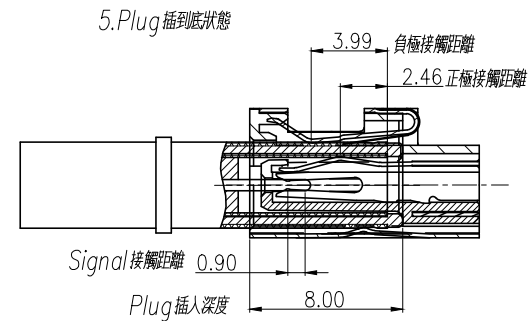
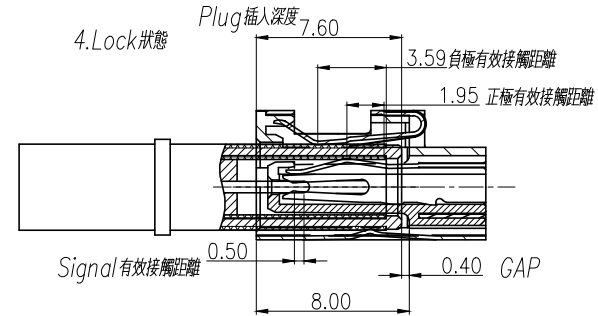
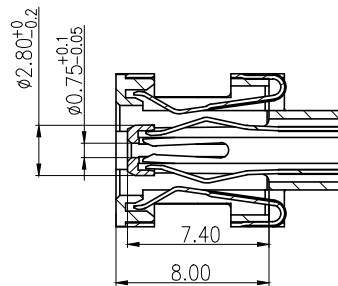

NO	DESCRIPTION	QTY	MATERIAL	PLATING & COLOR
UNLESS OTHERWISE SPECIFIED TOLERANCES			Singatron Enterprise Co., Ltd. 信音企業股份有限公司	
DECIMALS:	ANGLES:	TITLE	MATING DRAWING	
X :±0.5	X :±2'	DWN YUREN	PART NO. 2DC3071-030111F	
X.X :±0.3	X.X :±1'	CHKD CERRY	SCALE 4:1	UNIT: mm
X.XX :±0.2		APVD LIAO	SIZE: A3	SHEET:2 OF 2
REV: B				
CUSTOMER COPY				