

REV.	ECN NO OR DESCRIPTION	REVISED	DATE
A	PDR NO.T160204-1A	Jun	2016.08.19
B	ECN NO.S170538-R	YUREN	2017.8.11

SPECIFICATIONS:

- ELECTRICAL SPEC:
  - 1-1. RATED CURRENT: 6.5A
  - 1-2. RATED VOLTAGE: 20V
  - 1-3. INSULATION RESISTANCE: 100MΩ MIN. AFTER BY 500 VDC FOR 1 MINUTE
  - 1-4. DIELECTRIC WITHSTANDING VOLTAGE: 500V AC FOR 1 MINUTE.
  - 1-5. CONTACT RESISTANCE: 30mΩ MAX.(INITIAL)
- MECHANICAL SPEC:
  - 2-1. INSERTION FORCE: 3.0Kgf MAX..
  - 2-2. WITHDRAWAL FORCE : 0.4~2.5Kgf.
- WEIGHT: 1.0 GRAM.
- TEMPERATURE RISE CAN'T EXCEED 30°C MAX.
- LIFE TEST(INSERTION/WITHDRAWAL): 5,000 CYCLES MIN.
- OTHER GENERAL SPEC, PLEASE REFER TO "2DC3071 SERIES SPEC".
- HALOGEN FREE PRODUCT IDENTIFICATION MARK ON JACK: (C)
- HALOGEN FREE PRODUCT IDENTIFICATION LABEL ON PACKAGING: (H)
- FOR REFLOW SOLDERING LEAD-FREE PROCESS.
- THE PANEL'S ID MUST BE GREATER THAN THE PLUG'S OD WHICH MUST HAVE A DIFFERENCE OF LESS THAN OR EQUAL TO 0.50mm.(AS SHOWN IN FIGURE 1.)

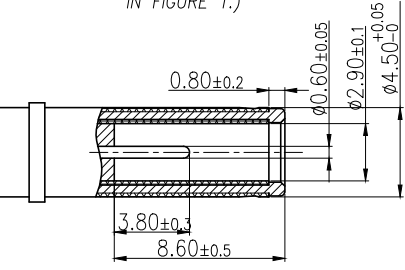
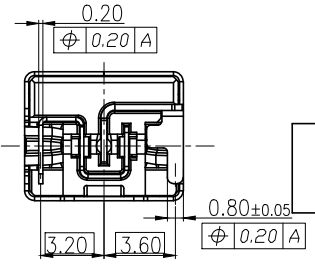
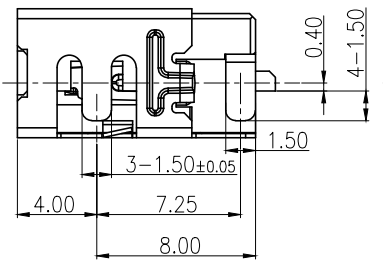
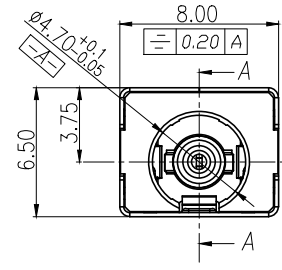
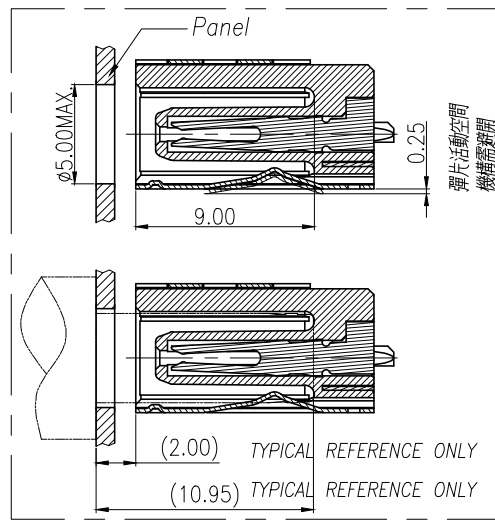
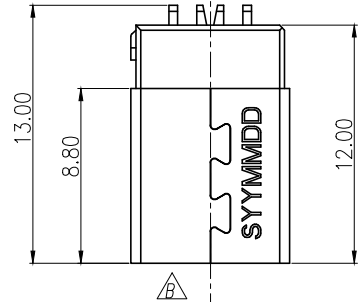
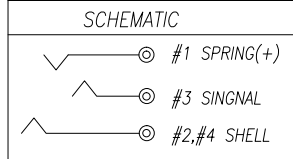

MATING PLUG  
TOLERANCE:X.XX:±0.10  
PLUG 型號 皇積 45P06CV230-1A00-01

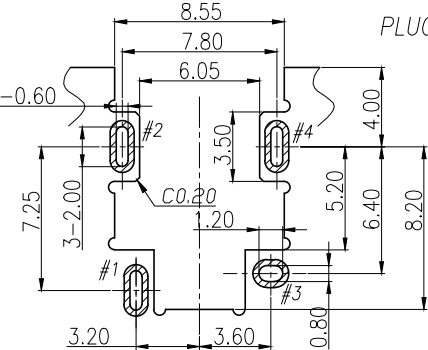
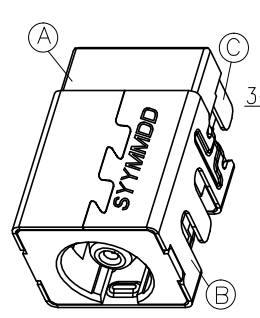
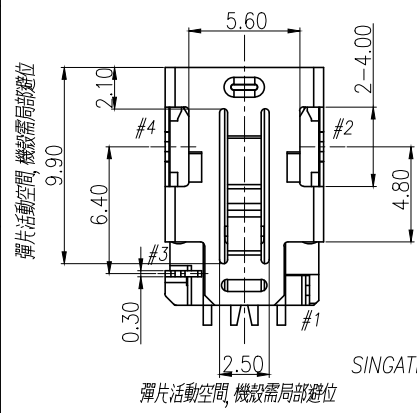
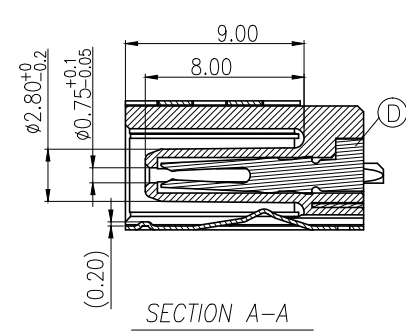

RECOMMEND P.C.B LAYOUT  
(TOLERANCES:±0.05) TOP VIEW

SINGATRON  
SYMMDD  
DD: DAY  
MM: MONTH  
YY: YEAR

D	SIGNAL	1	COPPER ALLOY 0.30T	Pd/Ni (25u" MIN.)&GOLD PLATED(5u" MIN.) ON CONTACT AREA; MATTE Sn 120u" MIN. ON SOLDER TAIL; ALL OVER Ni 50u" MIN.
C	SPRING(+)	1	COPPER ALLOY 0.20T	
B	SHELL	1	COPPER ALLOY 0.20T	Ni 60u" MIN.
A	BODY	1	HIGH TEMP.THERMOPLASTIC UL 94V-0	BLACK
ITEM	DESCRIPTION	QTY	MATERIAL/THICK(mm)	FINISH

UNLESS OTHERWISE SPECIFIED TOLERANCES		Singatron Enterprise Co., Ltd. 信音企業股份有限公司		
DECIMALS:	ANGLES:	TITLE: DC POWER JACK		
X :±0.5	X :±2°	DWN	YUREN	PART NO. 2DC3071-031111F
X.X :±0.3	X.X :±1°	CHKD	CERRY	SCALE 4:1 UNIT: mm
X.XX :±0.2		APVD	LIAO	SIZE: A3 SHEET:1 OF 2 REV:B
CUSTOMER COPY				

REV.	ECN NO OR DESCRIPTION	REVISED	DATE
A	PDR NO.T160204-1A	Jun	2016.08.19
B	ECN NO.S170538-R	YUREN	2017.8.11

1. NEGATIVE CONTACT FIRST

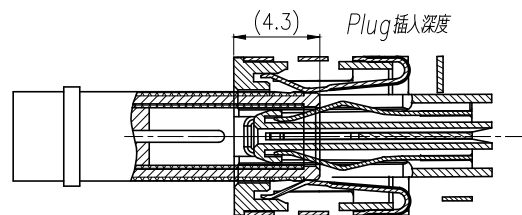

2. POSITIVE CONTACT

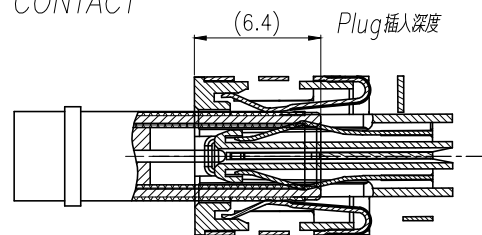

3. SIGNAL CONTACT

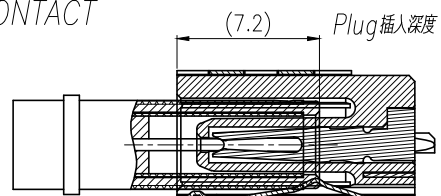

4. LOCK POSITION

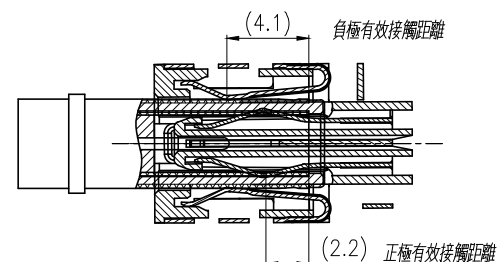
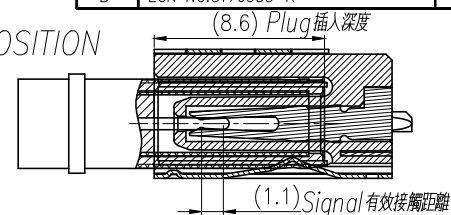

5. FULL INSERTION

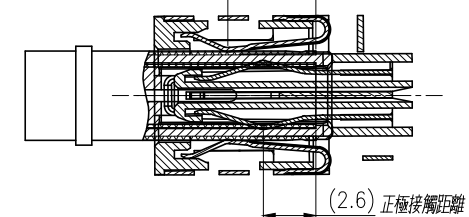
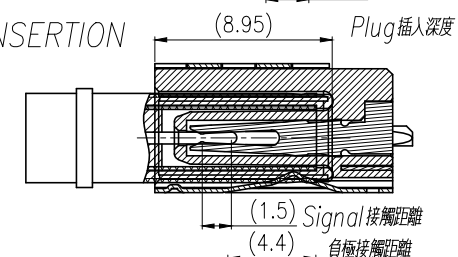

ITEM	DESCRIPTION	QTY	MATERIAL/THICK(mm)	FINISH
UNLESS OTHERWISE SPECIFIED TOLERANCES		Singatron Enterprise Co., Ltd. 信音企業股份有限公司		
DECIMALS: ANGLES:		TITLE: DC POWER JACK MATING		
X	:±0.5 X :±2°	DWN	YUREN	PART NO. 2DC3071-031111F
X.X	:±0.3 X.X :±1°	CHKD	CERRY	SCALE 4:1 UNIT: mm
X.XX	:±0.2	APVD	LIAO	SIZE: A3 SHEET:2 OF 2 REV:B
<b>CUSTOMER COPY</b>				