

REV.	ECN NO OR DESCRIPTION	REVISED	DATE
A	PDR NO.T210809-1A	Sugar	2022.01.17

**SPECIFICATIONS:**

- Electrical Spec:
  - Rated Current: 6.5A
  - Rated Voltage: 20V
  - Insulation Resistance: 100MΩ MIN. After By 500 VDC for 1 minute
  - Dielectric Withstanding Voltage: 500V AC for 1 minute.
  - Contact Resistance: 30mΩ Max.
- Mechanical Spec:
  - Insertion Force: 2.5Kgf Max.
  - Withdrawal Force : 0.6~2.5Kgf.
- Weight: 0.95 Gram.
- Temperature rise can't exceed 30°C MAX.
- Life Test(Insertion/Withdrawal): 5,000 Cycles Min.
- To Conform To SINGATRON Hazardous Substance Free Spec.
- Other general SPEC, please refer to "2DC3071-051111F SPEC".
- Halogen Free Product Identification Mark On Jack: Ⓢ
- Halogen Free Product Identification Label On Packaging: 
- For Reflow Soldering Lead-Free Process.
- Printed Date Code "SYMMDD" on top of connector.

SINGATRON DD: DAY MM: MONTH YY: YEAR  
 12. THE PANEL'S ID MUST BE GREATER THAN THE PLUG'S OD WHICH MUST HAVE A DIFFERENCE OF LESS THAN OR EQUAL TO 0.5 mm. (AS SHOWN IN FIGURE 1.)

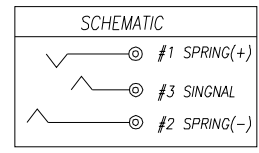
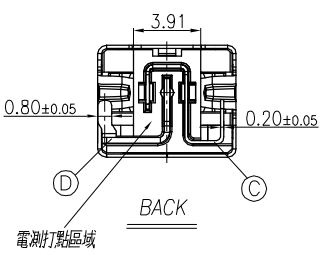
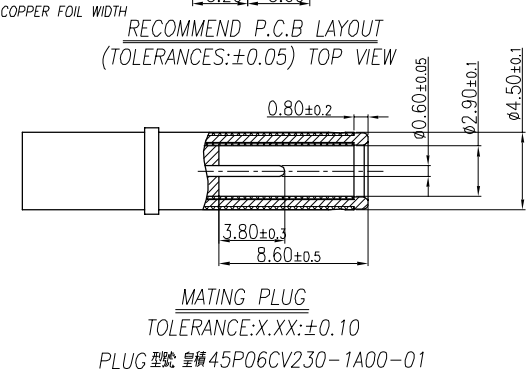
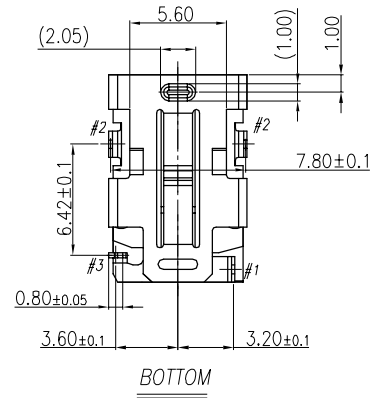
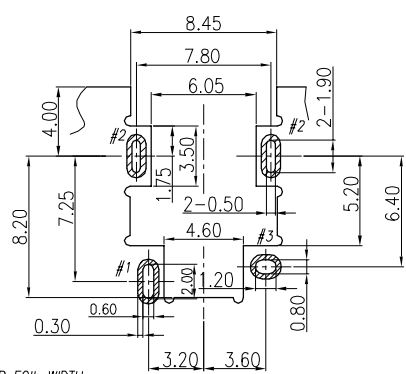
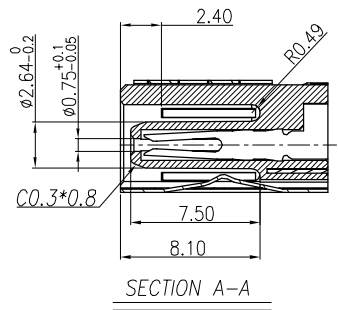
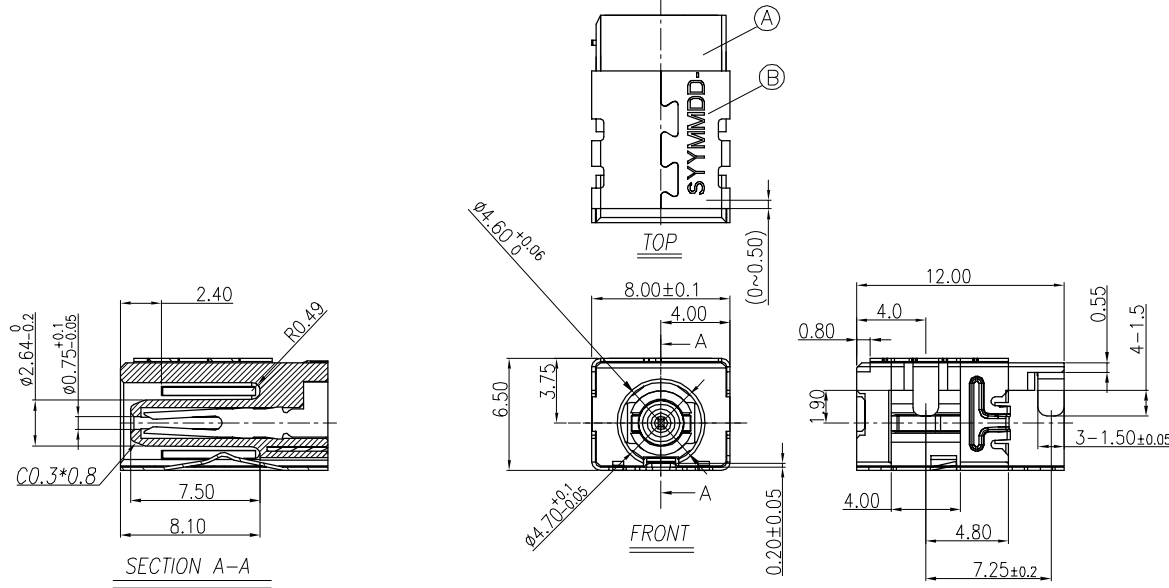
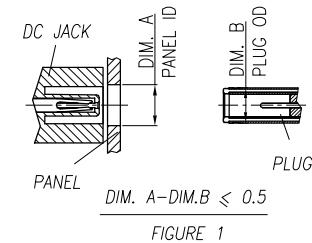

D	SIGNAL	1	C5210 0.30T	G/F On CONTACT AREA.
C	SPRING+	1	C5210 0.20T	MATTE SN 80u"MIN ON SOLDER TAIL. ALL OVER Ni 50u" Min .
B	SHELL	1	C5210 0.20T	GOLD FLASH ON SOLDER TAIL; OVER Ni 50u" MIN.
A	BODY	1	PA4T+30%GF UL 94V-0	BLACK
ITEM	DESCRIPTION	QTY	MATERIAL/THICK(mm)	FINISH
UNLESS OTHERWISE SPECIFIED TOLERANCES			Singatron Enterprise Co., Ltd. 信晉企業股份有限公司	
DECIMALS:		ANGLES:		TITLE
X	:±0.5	X	:±2°	DWN Sugar
X.X	:±0.3	X.X	:±1°	CHKD Lussen
X.XX	:±0.2			APVD Liao
DC POWER JACK				
<b>PART NO. 2DC3071-051111F</b>				
		SCALE 3:1	UNIT: mm	REV:A
		SIZE: A3	SHEET: 1 OF 2	
<b>CUSTOMER COPY</b>				

REV.	ECN NO OR DESCRIPTION	REVISED	DATE
A	PDR NO.T210809-1A	Sugar	2022.01.17

1, NEGATIVE FIRST

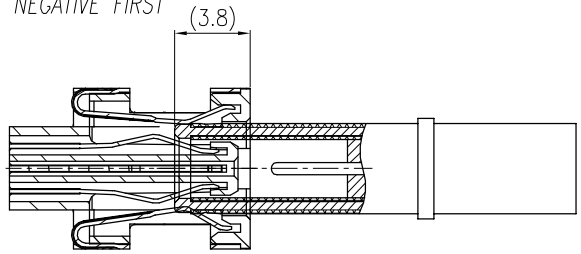

2, POSITIVE SECOND

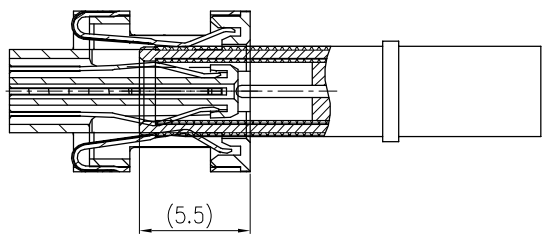

3, SIGNAL THIRD

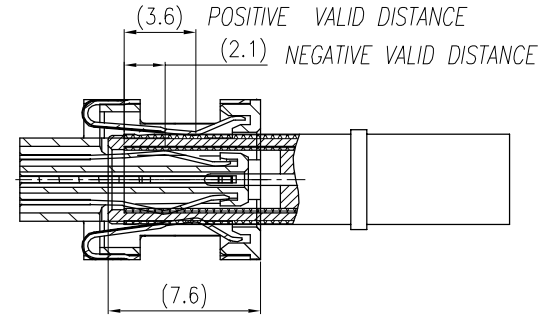
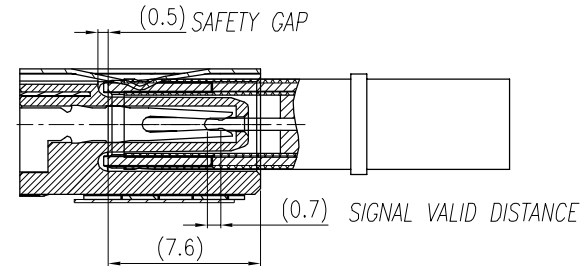
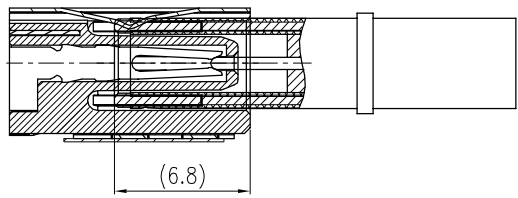

5. PLUG FULLY INSERTION

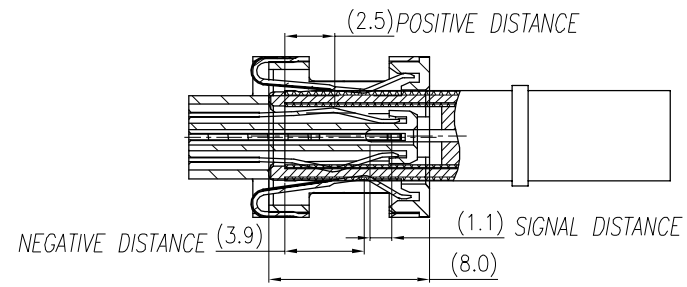

ITEM	DESCRIPTION	QTY	MATERIAL/THICK(mm)	FINISH
UNLESS OTHERWISE SPECIFIED TOLERANCES		Singatron Enterprise Co., Ltd. 信音企業股份有限公司		
DECIMALS:	ANGLES:	TITLE	DC POWER JACK	
X :±0.5	X :±2°	DWN	Sugar	<b>PART NO. 2DC3071-051111F</b>
X.X :±0.3	X.X :±1°	CHKD	Lussen	SCALE 4:1 UNIT: mm
X.XX :±0.2		APVD	Liao	SIZE: A3 SHEET: 2 OF 2 <b>REV:A</b>
<b>CUSTOMER COPY</b>				