

REV.	ECN NO OR DESCRIPTION	REVISED	DATE
A	PDR NO.T211117-1A	JIE-FU	2022.03.03

SPECIFICATIONS:

- ELECTRICAL CHARACTERISTICS:
  - RATING: 21V 15A;
  - CONTACT RESISTANCE: 30mΩ MAX.(INITIAL)
  - DIELECTRIC WITHSTANDING VOLTAGE: 150V AC FOR ONE MINUTE.
  - INSULATION RESISTANCE: 100MΩ MIN. MEASURED BY 500 VDC
- MECHANICAL CHARACTERISTICS:
  - INSERTION FORCE :3.0 KGF MAX.
  - WITHDRAWAL FORCE : 0.35 KGF MIN.
- LIFE TEST: 5,000 CYCLES MIN.
- WEIGHT: 2.5G.
- OTHER GENERAL SPEC. TO REFER "2DC3105-003111F SPEC".
- TO CONFORM TO SINGATRON HAZARDOUS SUBSTANCE FREE SPEC.
- HALOGEN FREE PRODUCT IDENTIFICATION MARK ON JACK: Ⓢ
- HALOGEN FREE PRODUCT IDENTIFICATION LABEL ON PACKAGING: Ⓢ
- FOR HAND SOLDERING LEAD-FREE PROCESS.
- PRINTED DATE CODE "YYMMDD" ON TOP OF CONNECTOR.

YYMMDD  
 DD: DAY  
 MM: MONTH  
 YY: YEAR

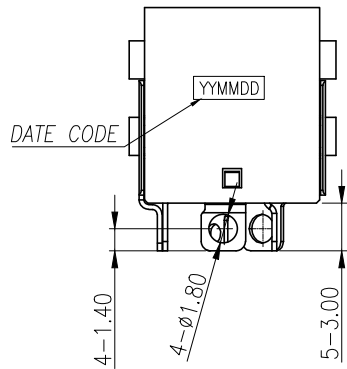
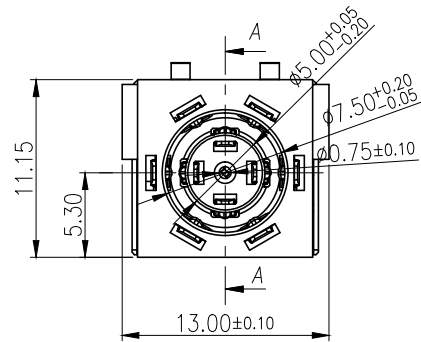
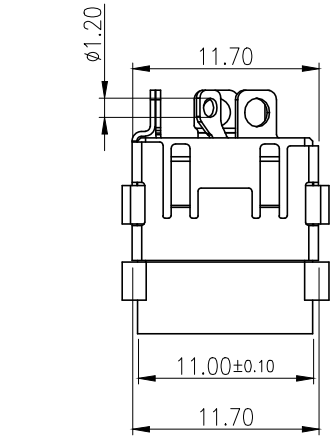
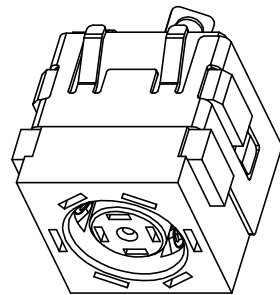
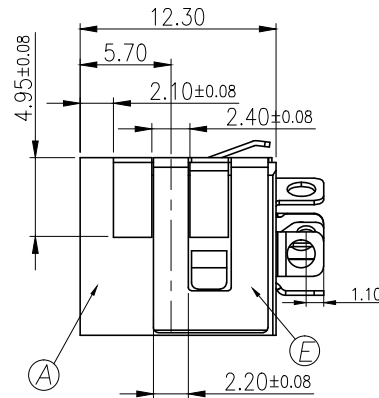
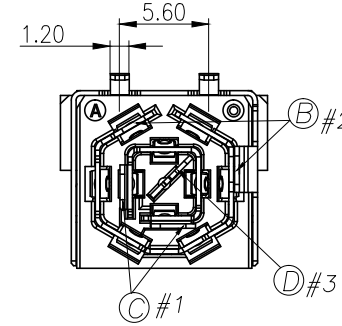
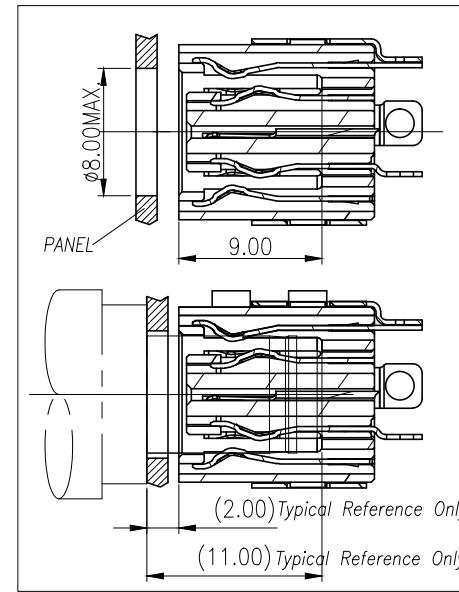
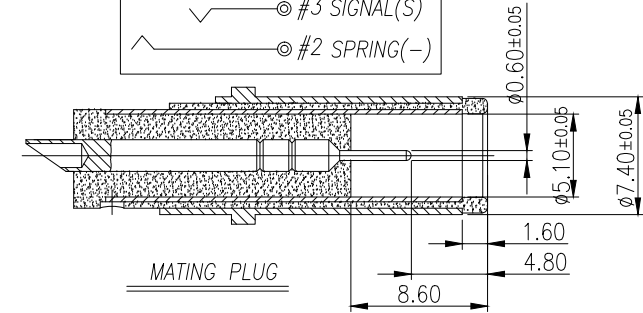
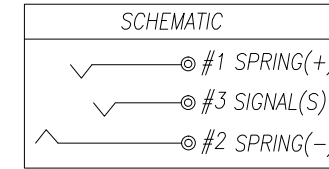

REV.	ECN NO OR DESCRIPTION	REVISED	DATE
A	PDR NO.T211117-1A	JIE-FU	2022.03.03

1. NEGATIVE CONTACT FIRST

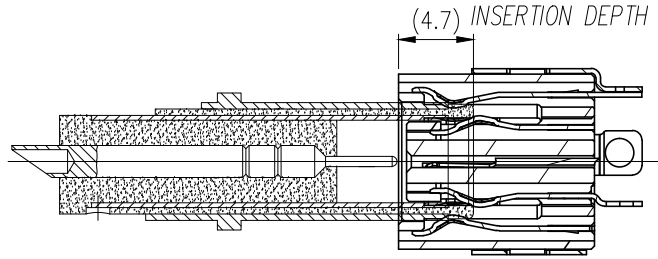

2. POSITIVE CONTACT SECOND

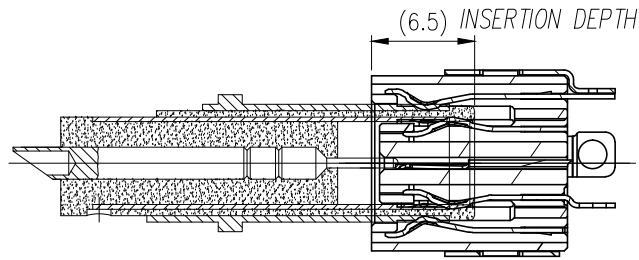

3. SIGNAL CONTACT

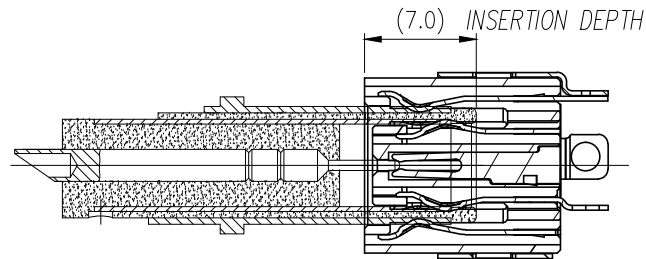

4. FULL INSERTION

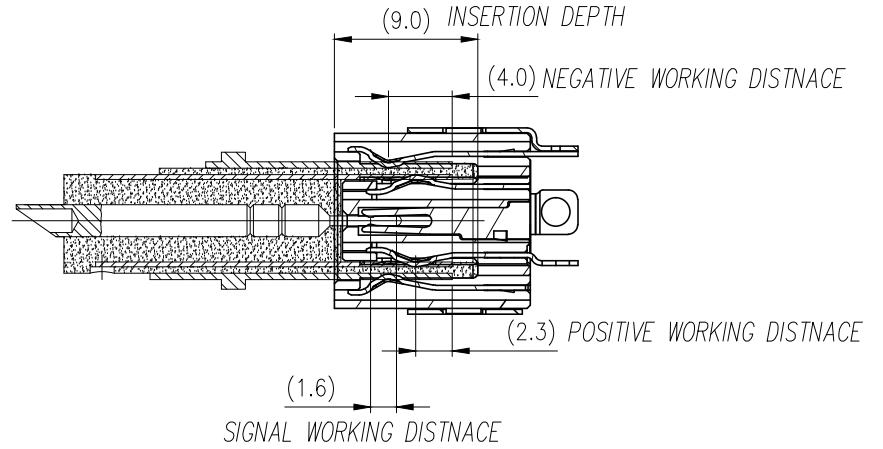

NO	DESCRIPTION	QTY	MATERIAL	PLATING & COLOR
UNLESS OTHERWISE SPECIFIED TOLERANCES		 Singatron Enterprise Co., Ltd. 信音企業股份有限公司		
DECIMALS:	ANGLES:	TITLE	DC POWER JACK	
X :±0.5	X :±2°	DWN JIE-FU	<b>PART NO.2DC3105-004111F</b>	
X.X :±0.3	X.X :±1°	CHKD LUSSEN	SCALE:4:1	UNIT: mm
X.XX :±0.2		APVD LIAO	SIZE: A3	SHEET:2 OF 2
<b>REV:A</b>				
<b>CUSTOMER COPY</b>				