

REV.	ECN NO OR DESCRIPTION	REVISED	DATE
A	PDR NO. T171026-3A	Zhijun	2018.06.20

- SPECIFICATIONS:
- ELECTRICAL CHARACTERISTICS:
    - CURRENT RATING: 20V/7A.
    - CONTACT RESISTANCE: 30mΩ MAX.(AFTER LIFE TEST)
    - DIELECTRIC WITHSTANDING VOLTAGE: 500V AC FOR 1 MINUTE.
    - INSULATION RESISTANCE: 100MΩ MIN. BY 500V DC.
  - MECHANICAL CHARACTERISTICS:
    - INSERTION FORCE: 2.0KGF MAX.
    - WITHDRAWAL FORCE: 1.0~2.0KGF(INITIAL);0.3~2.0KGF(AFTER LIFE TEST).
  - TEMPERATURE RISE CAN'T EXCEE 30°C.
  - LIFE TEST: 5,000 CYCLES.
  - WEIGHT: 1.8g.
  - TO CONFORM TO THE SINGATRON HAZARDOUS SUBSTANCE FREE SPEC.
  - HALOGEN FREE PRODUCT IDENTIFICATION MARK ON JACK: Ⓢ
  - HALOGEN FREE PRODUCT IDENTIFICATION LABEL ON PACKAGING: Ⓢ
  - FOR REFLOW SOLDERING LEAD-FREE PROCESS.
  - PRINTED DATE CODE "YYMMDD" ON TOP OF CONNECTOR.

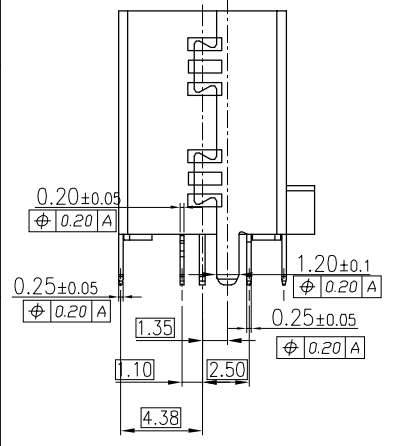
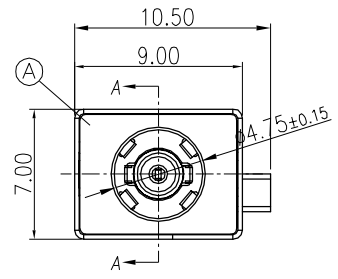
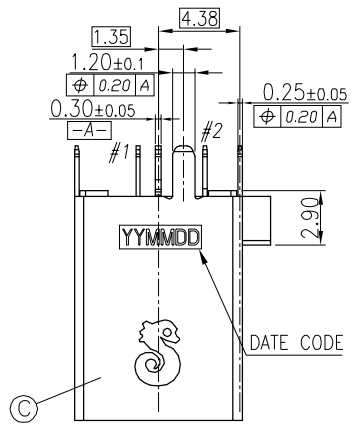
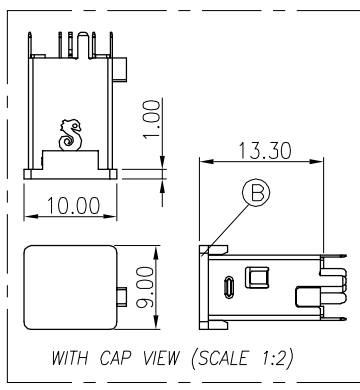
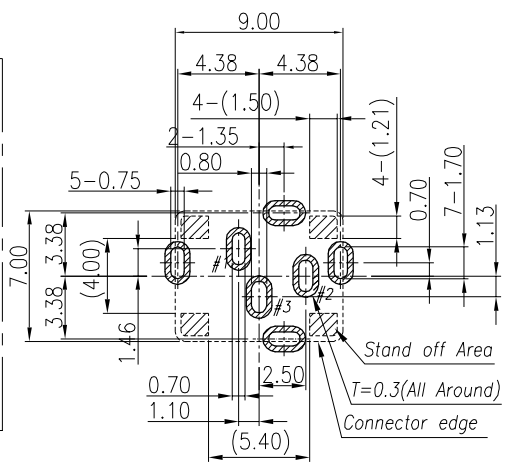
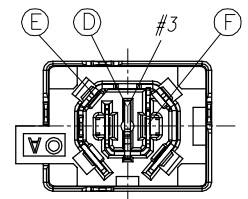
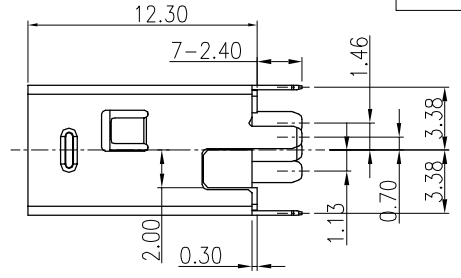
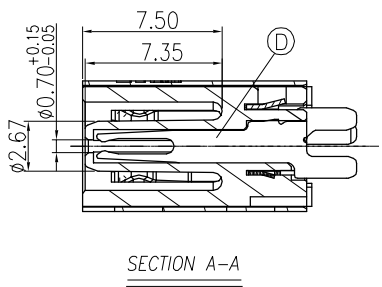
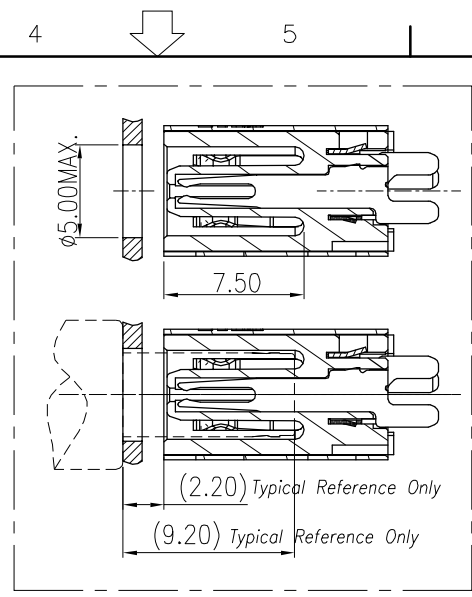
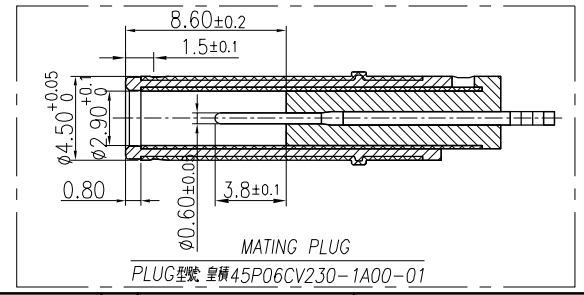
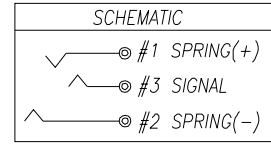

F	SPRING(+)	1	COPPER ALLOY 0.20T	Gold Flash On Contact Area.
E	SPRING(-)	1	COPPER ALLOY 0.25T	Matte Sn 120u"Min On Solder Tail.
D	SIGNAL	1	PHOSPHOR BRONZE 0.30T	All Over Ni 50u"Min.
C	SHELL	1	STAINLESS STEEL 0.25T	Ni 60u"Min.
B	CAP	1	PA4T (HALOGEN FREE)UL 94V-0	BLACK
A	BODY	1	LCP (HALOGEN FREE)UL 94V-0	BLACK
NO	DESCRIPTION	QTY	MATERIAL	PLATING & COLOR
UNLESS OTHERWISE SPECIFIED TOLERANCES			Singatron Enterprise Co., Ltd. 信音企業股份有限公司	
DECIMALS:		ANGLES:		
X	±0.5	X	±2°	
X.X	±0.3	X.X	±1°	
X.XX	±0.2			
TITLE		DC POWER JACK		
DWN	Zhijun	PART NO. 2DC3115-004111F		
CHKD	Sky	SCALE 4:1	UNIT: mm	Ⓢ
APVD	Lussen	SIZE: A3	SHEET: 1 OF 2	REV:A
CUSTOMER COPY				

REV.	EGN NO.	OR DESCRIPTION	REVISED	DATE
A	PDR NO.	1171026-3A	ZhiJun	2018.06.10

### 1. NEGATIVE CONTACT FIRST

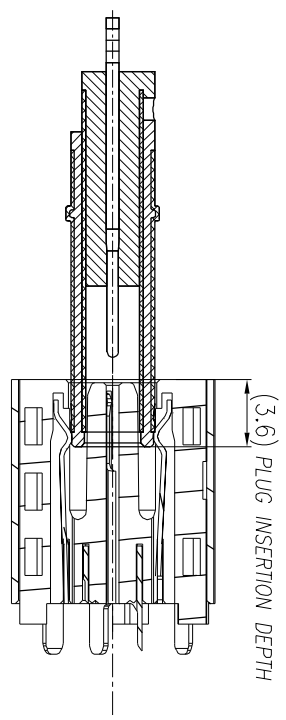

### 2. POSITIVE CONTACT

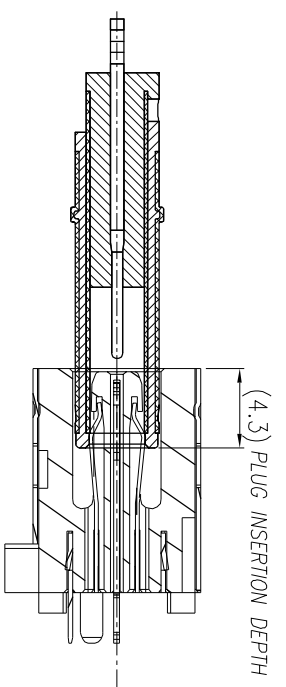

### 4. FULL INSERTION

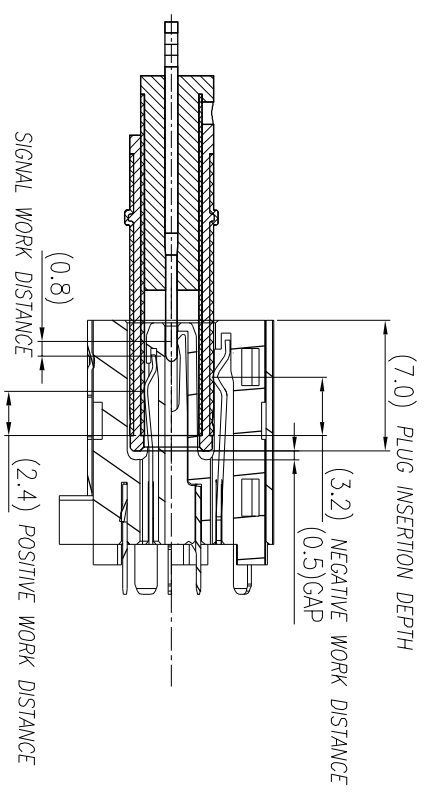

### 3. SIGNAL CONTACT

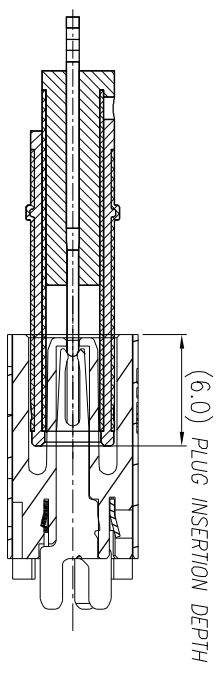

NO	DESCRIPTION	QTY	MATERIAL	PLATING & COLOR
UNLESS OTHERWISE SPECIFIED TOLERANCES				
DECIMALS: ANGLES:				
X	:±0.5	X	:±2°	
X.X	:±0.3	X.X	:±1°	
X.XX	:±0.2			
TITLE DC POWER JACK				
DWN	ZhiJun	PART NO. 2DC3115-004111F		
CHKD	Sky	SCALE 4:1	UNIT: mm	
APVD	Lussen	SIZE: A3	SHEET: 2 OF 2	REV: A

CUSTOMER COPY



Singatron Enterprise Co., Ltd.  
 信音企業股份有限公司