

1 2 3 4 5 6 7 8

REV.	ECN NO OR DESCRIPTION	REVISED	DATE
A	PDR NO. T180524-1A	Springwu	2019.3.8
B	ECN NO. S202010-C02	Ken	2020.12.16

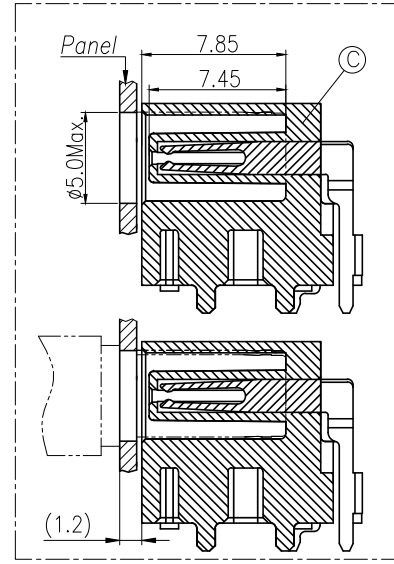
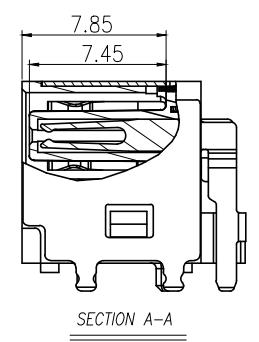
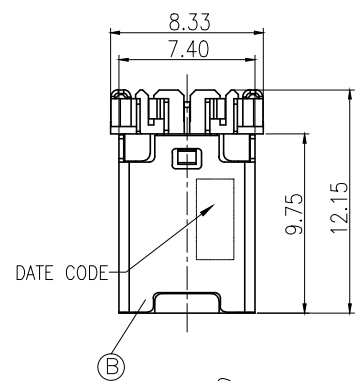

SPECIFICATIONS:

- ELECTRICAL CHARACTERISTICS:
  - RATING: 20V 6A
  - CONTACT RESISTANCE: 30mΩ MAX.
  - DIELECTRIC WITHSTANDING VOLTAGE: 500V AC FOR ONE MINUTE.
  - INSULATION RESISTANCE: 100MΩ MIN. MEASURED BY 500 VDC
- MECHANICAL CHARACTERISTICS:
  - INSERTION FORCE: 3.0 Kgf MAX.
  - WITHDRAWAL FORCE: 0.3~3.0Kgf.
- LIFE TEST: 5,000 CYCLES.
- TO CONFORM TO SINGATRON HAZARDOUS SUBSTANCE FREE SPEC.
- HALOGEN FREE PRODUCT IDENTIFICATION MARK ON PRODUCT:
- HALOGEN FREE PRODUCT IDENTIFICATION LOGO ON PACKAGING:
- FOR REFLOW SOLDERING LEAD-FREE PROCESS.

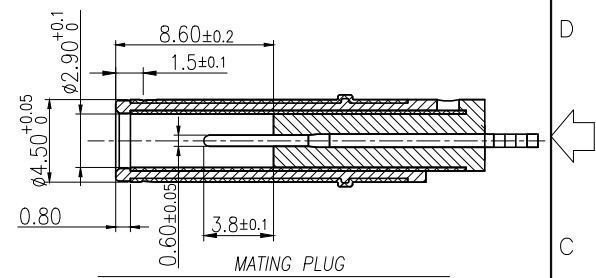
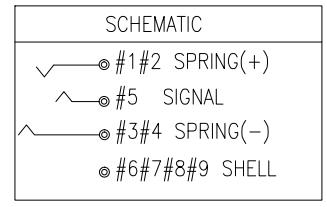
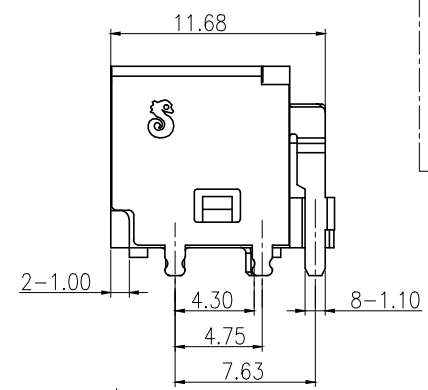
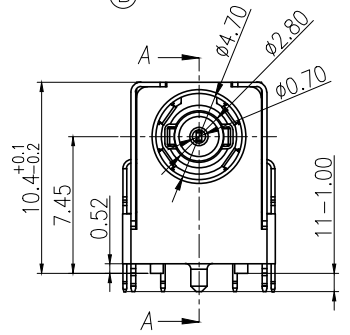

PLUG 型號 皇碩 45P06CV230-1A00-01

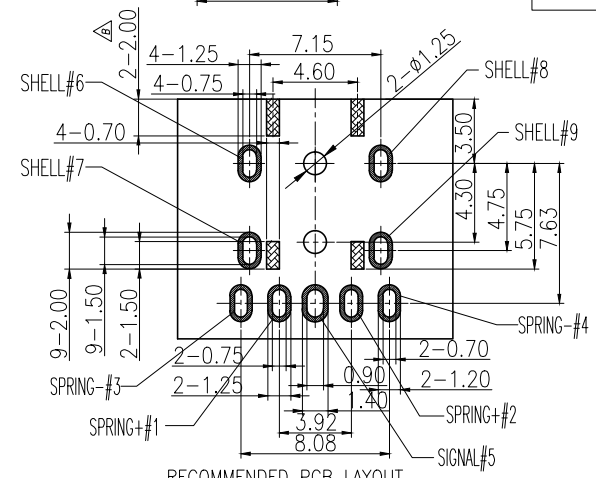
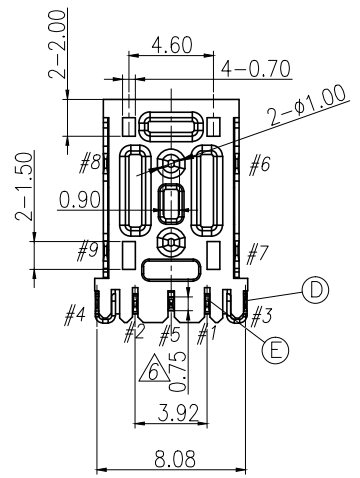

RECOMMENDED PCB LAYOUT  
COMPONENT SIDE (TOLERANCE: ±0.05)

NO	DESCRIPTION	QTY	MATERIAL	PLATING & COLOR
E	SPRING(+)	1	COPPER ALLOY 0.20T	Au 30u" ON CONTACT AREA;
D	SPRING(-)	1	COPPER ALLOY 0.25T	MATTE Sn 120u" ON SOLDER AREA OVER Ni 50u"Min.
C	SIGNAL	1	COPPER ALLOY 0.30T	G/F ON CONTACT, MATTE SN 120u" ON SOLDER, ALL OVER Ni 50u"Min.
B	SHELL	1	SUS 0.25T	Ni 50u"Min.
A	BODY	1	HIGH TEMP.THERMOPLASTIC UL 94V-0	BLACK
UNLESS OTHERWISE SPECIFIED TOLERANCES				
DECIMALS: ANGLES:				
X	:±0.5	X	:±2°	
X.X	:±0.3	X.X	:±1°	
X.XX	:±0.2			
TITLE		DC POWER JACK		
DWN	ken	PART NO. 2DC3122-011111F		
CHKD	Sky	SCALE 4:1	UNIT: mm	
APVD	Lussen	SIZE: A3	SHEET: 1 OF 2	REV: B
CUSTOMER COPY				

1 2 3 4 5 6 7 8 文件編號 RD-06-043-A

REV.	ECN NO OR DESCRIPTION	REVISED	DATE
A	PDR NO. T180524-1A	Springwu	2019.3.8
B	ECN NO. S202010-C02	Ken	2020.12.16

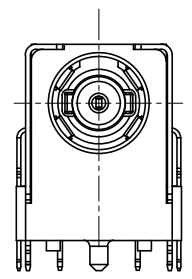
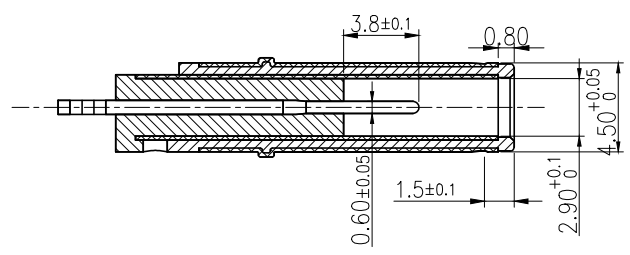

1. SPRING(-) CONTACT

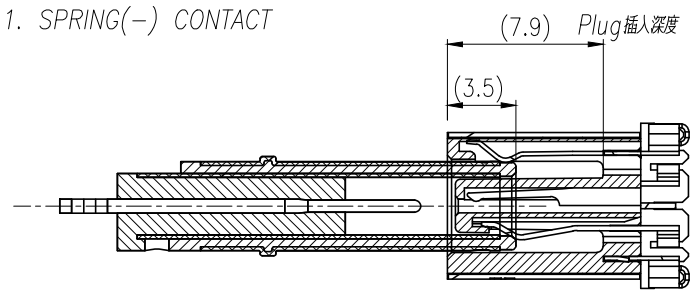

2. PIN(+) CONTACT

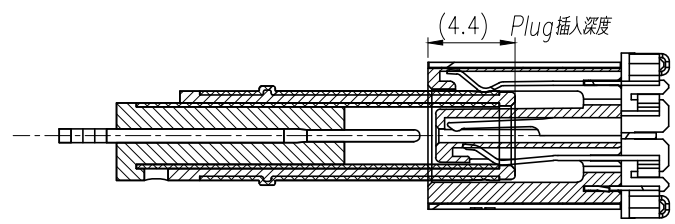

3. SIGNAL PIN CONTACT

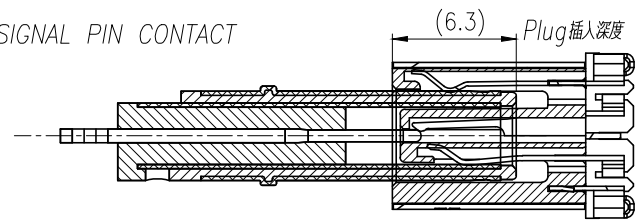

4. FULL INSERTION

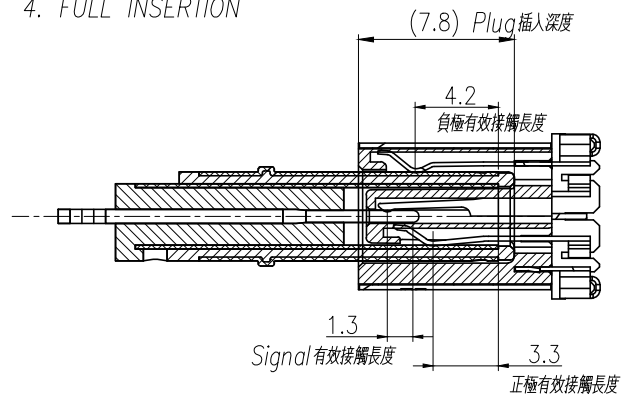

UNLESS OTHERWISE SPECIFIED TOLERANCES		Singatron Enterprise Co., Ltd. 信音企業股份有限公司	
DECIMALS:	ANGLES:	TITLE MATTING DRAWING	
X :±0.5	X :±2°	DWN	ken PART NO. 2DC3122-01111F
X.X :±0.3	X.X :±1°	CHKD	Sky SCALE 4:1 UNIT: mm
X.XX :±0.2		APVD	Lussen SIZE: A3 SHEET:2 OF 2 REV:B
CUSTOMER COPY			