

RECOMMEND P.C.B LAYOUT(T=1.0mm)

- SPECIFICATIONS:
- ELECTRICAL CHARACTERISTICS:
 - RATING: 20V 5A
 - CONTACT RESISTANCE: 15mΩ MAX.
 - DIELECTRIC WITHSTANDING VOLTAGE: 500V AC FOR ONE MINUTE.
 - INSULATION RESISTANCE: 100MΩ MIN. MEASURED BY 500 VDC
 - MECHANICAL CHARACTERISTICS:
 - INSERTION FORCE : 0.8~2.0kgf (INITIAL/AFTER LIFE TEST)
 - WITHDRAWAL FORCE : 0.8~2.0kgf (INITIAL/AFTER LIFE TEST)
 - TEMPERATURE RISE CAN'T EXCEED 30°C
 - LIFE TEST: 8,000 CYCLES .
 - WEIGHT: 1.157 g
 - TO CONFORM TO SINGATRON HAZARDOUS SUBSTANCE FREE SPEC.
 - HALOGEN FREE PRODUCT IDENTIFICATION MARK ON JACK: (H)
 - HALOGEN FREE PRODUCT IDENTIFICATION LABEL ON PACKAGING: (H)
 - FOR REFLOW SOLDERING LEAD-FREE PROCESS.
 - PRINTED DATE CODE "YYMMDD" ON TOP OF CONNECTOR.

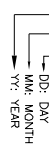

| ITEM | DESCRIPTION | QTY | MATERIAL | PLATING & COLOR |
|------|----------------|-----|-------------------------|---|
| C | SHELL | 1 | SPAINLESS STEEL, SUS304 | Ni 60U *MIN. |
| B | SPRING(-) | 1 | PHOSPHOR BRONZE, C5210 | MATTE Sn120U *Min, OVER Ni50U *Min. |
| A | INSERT MOLDING | 1 | PIN-BRASS, C2680 | GOLD FLASH ON CONTACT AREA Sn 120U * ON SOLDER TAIL ALL OVER Ni 50U * Min |
| | DESCRIPTION | 1 | BODY: PAAT, UJ941-0 | BLACK |

UNLESS OTHERWISE SPECIFIED TOLERANCES

| DECIMALS: | ANGLES: | TITLE | DC POWER JACK |
|-------------|-----------|-------------|-------------------------------|
| X : ±0.5 | X : ±2° | DWN Allen | PART NO. 2DC3137-007111F |
| X.X : ±0.3 | X.X : ±1° | CHKD Sky | SCALE 4:1 UNIT: mm |
| X.XX : ±0.2 | | APVD Lussen | SIZE: A3 SHEET: 1 OF 2 REV: A |

Singatron Enterprise Co., Ltd.
信音企業股份有限公司

CUSTOMER COPY

| REV. | ECN NO OR DESCRIPTION | REVISED | DATE |
|------|-----------------------|---------|------------|
| A | PDR NO.T150311-2A | Allen | 2015.08.27 |

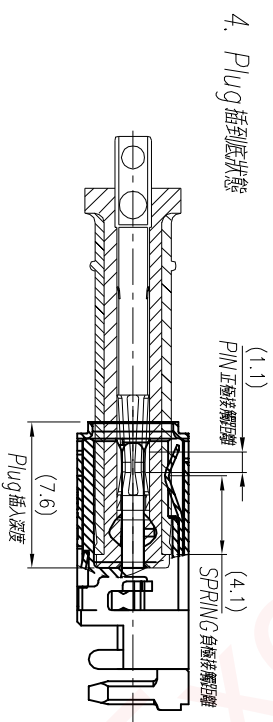
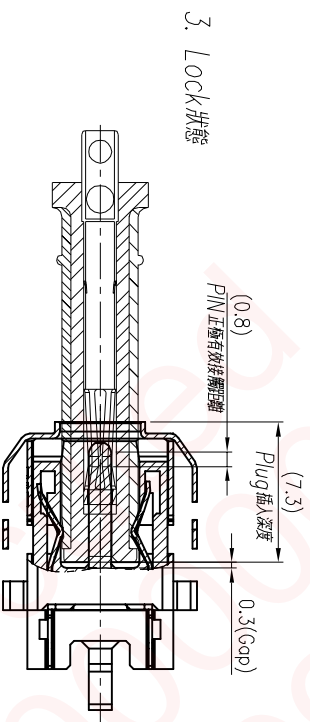
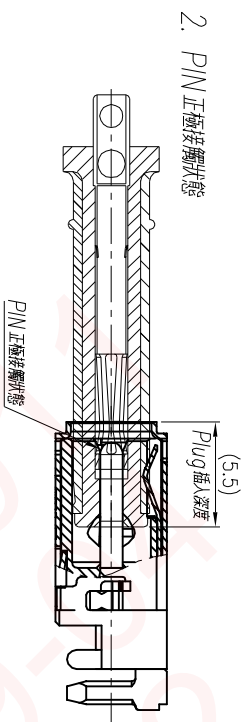
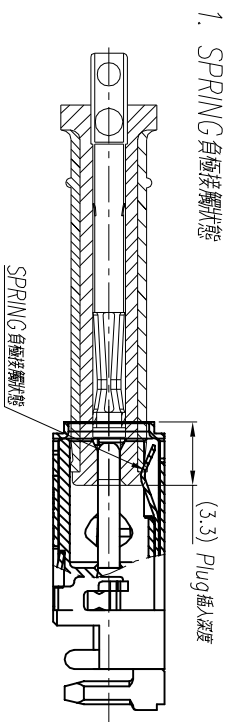

| REV. | ECN NO. OR DESCRIPTION | REVISED | DATE |
|------|------------------------|---------|------------|
| A | PDR NO. T150311-2A | Allen | 2015.08.27 |

| ITEM | DESCRIPTION | QTY | MATERIAL | PLATING & COLOR |
|---------------------------------------|------------------------------|--------------------------|----------|-----------------|
| UNLESS OTHERWISE SPECIFIED TOLERANCES | | | | |
| DECIMALS: | ANGLES: | | | |
| X : ±0.5 | X : ±2° | | | |
| X.X : ±0.3 | X.X : ±1° | | | |
| X.XX : ±0.2 | | | | |
| TITLE | DC POWER JACK_MATING DRAWING | | | |
| DWN | Allen | PART NO. 2DC3137-007111F | | |
| CHKD | Sky | SCALE | 4:1 | UNIT: mm |
| APVD | Lussen | SIZE: | A3 | SHEET: 2 OF 2 |
| REV: A | | | | |

CUSTOMER COPY