

(+) APPLICABLE WRE LUMTS : ANG #24 X 4  
 (-) APPLICABLE WRE LUMTS : ANG #24 X 4

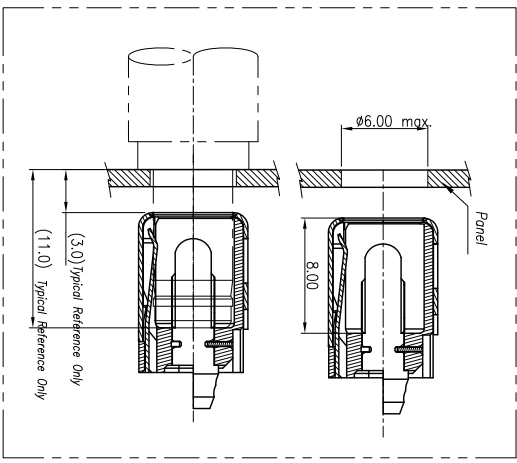

- SPECIFICATIONS:
- ELECTRICAL CHARACTERISTICS:
    - RATING: 20V 10A
    - CONTACT RESISTANCE: 15mΩ MAX.
    - DILECTRIC WITHSTANDING VOLTAGE: 500V AC FOR ONE MINUTE.
    - INSULATION RESISTANCE: 100MΩ MIN. MEASURED BY 500 VDC
  - MECHANICAL CHARACTERISTICS:
    - INSERTION FORCE: 0.8~2.0 kgf (INITIAL / AFTER LIFE TEST)
    - WITHDRAWAL FORCE: 0.8~2.0 kgf (INITIAL / AFTER LIFE TEST)
    - TEMPERATURE RISE CANT EXCEED 30°C
    - LIFE TEST: 6,000 CYCLES MIN.
    - WEIGHT: 1.98 g
    - OTHER GENERAL SPEC. TO REFER "2DC3156 SERIES SPEC."
    - TO CONFORM TO SINGATRON HAZARDOUS SUBSTANCE FREE SPEC.
    - HALOGEN FREE PRODUCT IDENTIFICATION MARK ON JACK
    - HALOGEN FREE PRODUCT IDENTIFICATION LABEL ON PACKAGING.
    - FOR HAND SOLDERING LEAD-FREE PROCESS.
    - PRINTED DATE CODE TMMDD ON TOP OF CONNECTOR.

SCHEMATIC

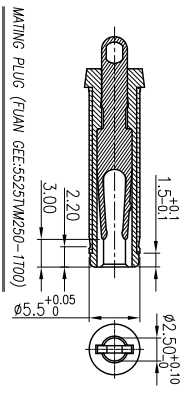
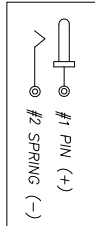

E	SHELL	1	STAINLESS 0.3T (SUS 304)	Ni: 60u" MIN.
D	TERMINAL	1	STAINLESS 0.3T (SUS 301)	N/A
C	PIN	1	BRASS BAR(HB99-1.99)	GOLD FLASH OVER Ni: 50u"
B	SPRING	1	PHOSPHOR BRONZE (C5210-EH 0.25T)	MATTE Sn 120u" OVER Ni: 60u"
A	BODY	1	PA 4T +308GF UL 94V-0	BLACK

UNLESS OTHERWISE SPECIFIED TOLERANCES

ITEM	DESCRIPTION	QTY	MATERIAL	PLATING & COLOR
Singatron Enterprise Co., Ltd. 信晉企業股份有限公司				
TITLE: DC POWER JACK				
DWN	Ron	PART NO. 2DC3156-000111F	SCALE: --	UNIT: mm
CHKD	Sky	SIZE: A3	SHEET: 1 OF 2	REV: A
APVD	Lussen	CUSTOMER COPY		

DECIMALS: ANGLES: X : ±0.5 X : ±2° X.X : ±0.3 X.X : ±1° X.XX : ±0.2

REV.	ECN NO.	OR DESCRIPTION	REVISED	DATE
A	PDR NO. T141119-4A	Ron		2016.01.13

1. 負極接觸狀態:

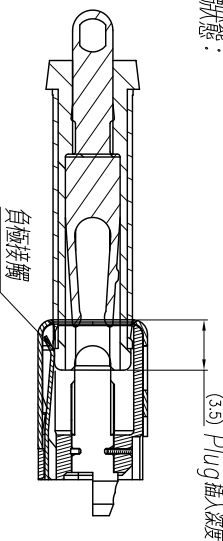

2. 正極接觸狀態:

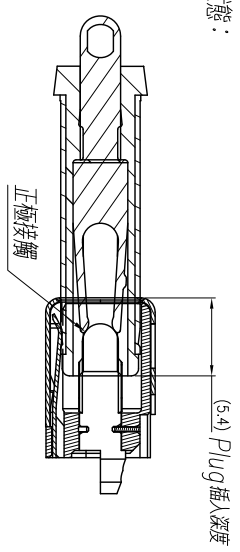

3. Lock 狀態狀態:

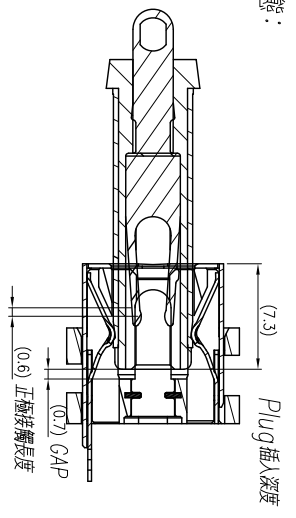

4. Full Mating 狀態:

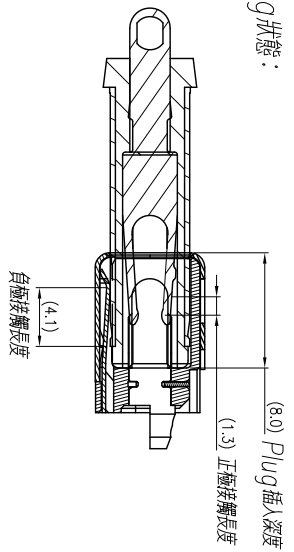

ITEM	DESCRIPTION	QTY	MATERIAL	PLATING & COLOR
UNLESS OTHERWISE SPECIFIED TOLERANCES				
DECIMALS: X :±0.5 X X.X :±0.3 X.X.X :±0.2				
ANGLES: X :±2° X.X :±1° X.X.X :±0.2				
TITLE	DC POWER JACK_MATING DRAWING			
DWN	Ron			
CHKD	Sky			
APVD	Lussen			
PART NO. 2DC3156-000111F				
SCALE: --				
UNIT: mm				
SIZE: A3				
SHEET: 2 OF 2				
REV: A				
CUSTOMER COPY				

 Singotron Enterprise Co., Ltd.  
 信普企業股份有限公司

