

REV.	ECN NO OR DESCRIPTION	REVISED	DATE
A	PDR NO.T170322-1A	Boru	2017.09.13

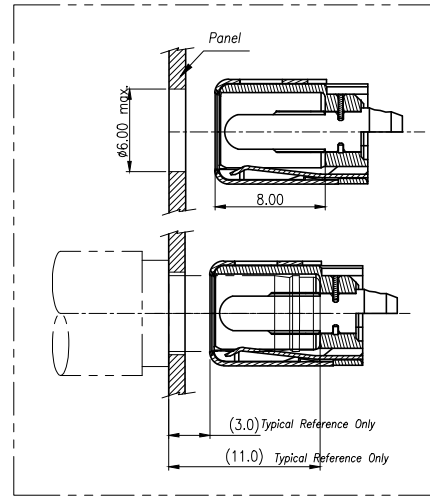
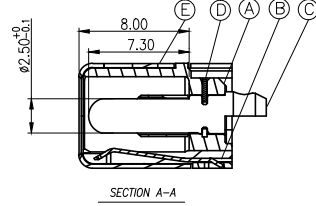
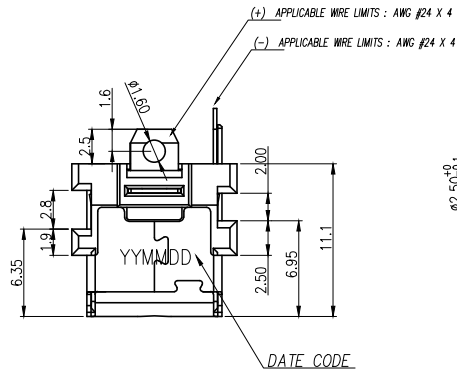

SPECIFICATIONS:

- ELECTRICAL CHARACTERISTICS:
  - 1-1. RATING: 20V 10A
  - 1-2. CONTACT RESISTANCE: 30mΩ MAX.
  - 1-3. DIELECTRIC WITHSTANDING VOLTAGE: 500V AC FOR ONE MINUTE.
  - 1-4. INSULATION RESISTANCE: 100MΩ MIN. MEASURED BY 500 VDC
- MECHANICAL CHARACTERISTICS:
  - 2-1. INSERTION FORCE : 3.0 kgf Max.
  - 2-2. WITHDRAWAL FORCE : 0.5~3.0 kgf
- TEMPERATURE RISE CAN'T EXCEED 30°C
- LIFE TEST: 8,000 CYCLES MIN.
- OTHER GENERAL SPEC. TO REFER "2DC3156-003111F SPEC".
- TO CONFORM TO SINGATRON HAZARDOUS SUBSTANCE FREE SPEC.
- HALOGEN FREE PRODUCT IDENTIFICATION MARK ON JACK: (C)
- HALOGEN FREE PRODUCT IDENTIFICATION LABEL ON PACKAGING: (C)
- FOR HAND SOLDERING LEAD-FREE PROCESS.
- PRINTED DATE CODE "YYMMDD" ON TOP OF CONNECTOR.

DD: DAY  
MM: MONTH  
YY: YEAR

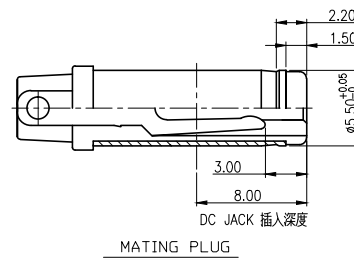
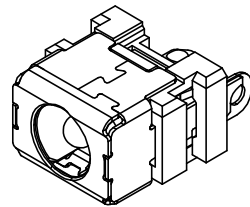
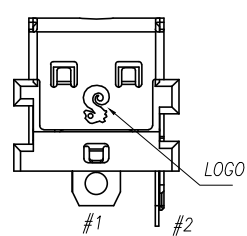
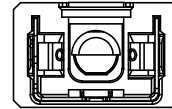
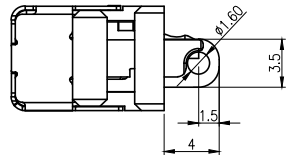
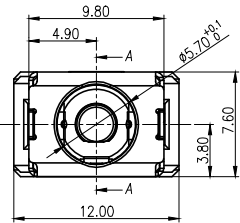
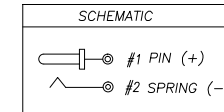

ITEM	DESCRIPTION	QTY	MATERIAL	PLATING & COLOR
E	SHELL	1	STAINLESS 0.3T	Ni 60u" MIN.
D	TERMINAL	1	STAINLESS 0.3T	N/A
C	PIN	1	BRASS BAR	GOLD FLASH OVER Ni 50u"
B	SPRING	1	PHOSPHOR BRONZE 0.25T	MATTE Sn 120u" OVER Ni 60u"
A	BODY	1	THERMOPLASTIC,UL94V-0	BLACK

UNLESS OTHERWISE SPECIFIED TOLERANCES

Singatron Enterprise Co., Ltd.  
信音企業股份有限公司

DECIMALS:	ANGLES:	TITLE	DC POWER JACK		
X :±0.5	X :±2°	DWN	Boru	PART NO.2DC3156-003111F	
X.X :±0.3	X.X :±1°	CHKD	Sky	SCALE --	UNIT: mm
X.XX :±0.2		APVD	Lussen	SIZE: A3	SHEET:1 OF 2

CUSTOMER COPY

REV.	ECN NO OR DESCRIPTION	REVISED	DATE
A	PDR NO.T170322-1A	Boru	2017.09.13

1. 負極接觸狀態：

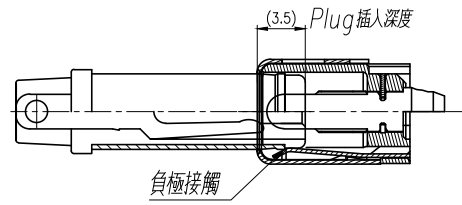

2. 正極接觸狀態：

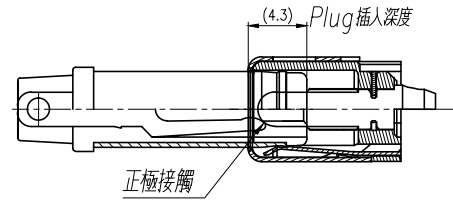

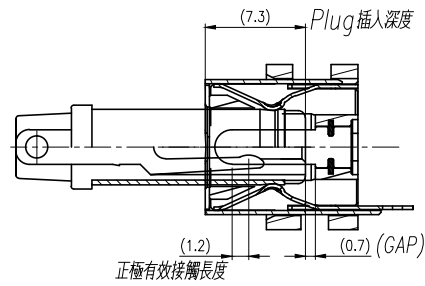

3. Lock 狀態狀態：

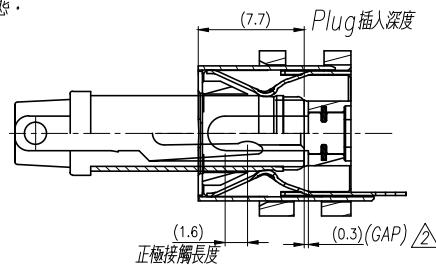

4. Full Mating 狀態：



ITEM	DESCRIPTION	QTY	MATERIAL	PLATING & COLOR
UNLESS OTHERWISE SPECIFIED TOLERANCES		 Singatron Enterprise Co., Ltd. 信音企業股份有限公司		
DECIMALS: ANGLES:		TITLE: DC POWER JACK_MATING DRAWING		
X	:±0.5 X :±2°	DWN	Boru	<b>PART NO.2DC3156-003111F</b>
X.X	:±0.3 X.X :±1°	CHKD	Sky	SCALE -- UNIT: mm 
X.XX	:±0.2	APVD	Lussen	SIZE: A3 SHEET:2 OF 2 <b>REV:A</b>
<b>CUSTOMER COPY</b>				