

- SPECIFICATIONS:
- ELECTRICAL CHARACTERISTICS:
    - RATING: 20V 5A;
    - CONTACT RESISTANCE: 30mΩ MAX.(INITIAL)
    - DIELECTRIC WITHSTANDING VOLTAGE: 500V AC FOR ONE MINUTE.
    - INSULATION RESISTANCE: 100M Ω·MIN. MEASURED BY 500 VDC
  - MECHANICAL CHARACTERISTICS:
    - INSERTION FORCE : 3.0 KGf MAX.
    - WITHDRAWAL FORCE : 1.0~2.5 KGf(INITIAL); 0.70~2.5KGf (MIN(AFTER LIFE TEST));
    - LIFE TEST: 5,000 CYCLES MIN.
    - OTHER GENERAL SPEC. TO REFER "2DC3187-000111F SPEC".
    - TO CONFORM TO SINGATRON HAZARDOUS SUBSTANCE FREE SPEC.
    - HALOGEN FREE PRODUCT IDENTIFICATION MARK ON JACK: Ⓢ
    - HALOGEN FREE PRODUCT IDENTIFICATION LABEL ON PACKAGING: Ⓢ
    - FOR REFLOW SOLDERING LEAD-FREE PROCESS.
    - PRINTED DATE CODE "YYMMDD" ON TOP OF CONNECTOR.

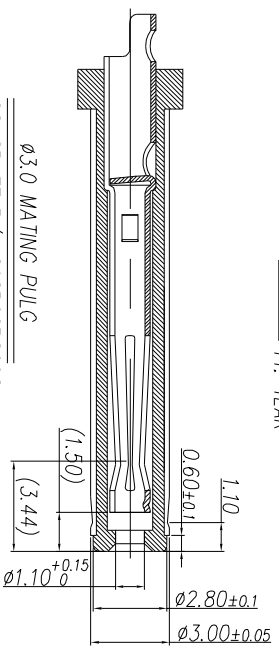

CONCRAFT P/N: 208P02BG00C

Ø3.0 MATING PULG

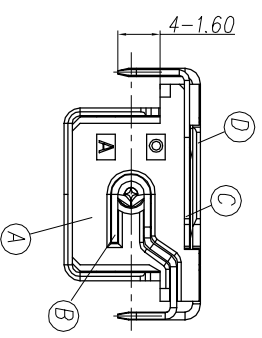
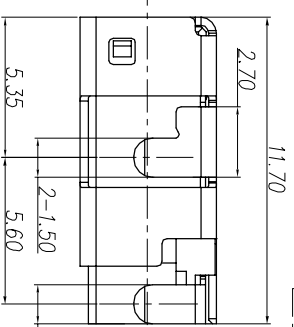
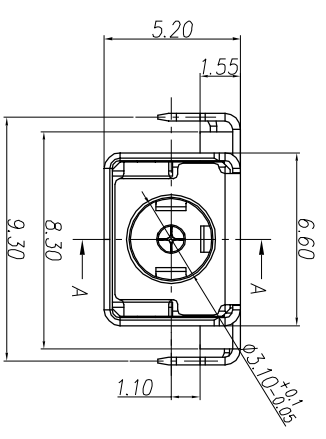
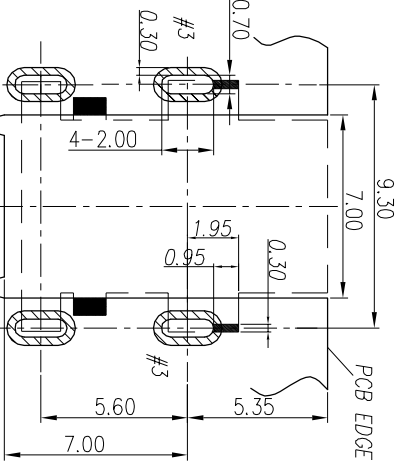
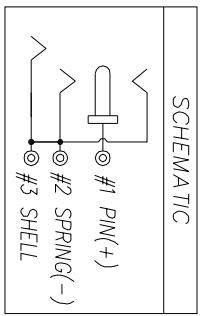
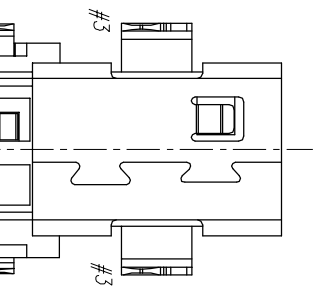

RECOMMENDED PCB LAYOUT TOLERANCE ±0.05(TOP VIEW)

NO	DESCRIPTION	QTY	MATERIAL	PLATING & COLOR
D	SHELL	1	STAINLESS	Ni 60u"
C	SPRING	1	COPPER ALLOY 0.2T	Matte Sn 80u" OVER Ni 50u" Δ
B	PIN	1	COPPER ALLOY 0.25T	GOLD FLASH ON CONTACT AREA; Matte Sn 120u" PLATED ON SOLDER TAIL; ALL OVER Ni 50u" MIN.
A	BODY	1	HIGH THERMOPLASTIC (HALOGEN FREE) U94V-0	BLACK

UNLESS OTHERWISE SPECIFIED TOLERANCES

DECIMALS: ANGLES:

X : ±0.5 X : ±2°

XX : ±0.3 X.X : ±1°

X.XX : ±0.2

TITLE: DC POWER JACK

DWG: Springwu PART NO. 2DC3187-000111F

CHKD: Sky SCALE 5:1 UNIT: mm

APVD: Lussen SIZE: A3 SHEET: 1 OF 2 REV: A

Singatron Enterprise Co., Ltd. 信達企業股份有限公司

REV.	ECN NO OR DESCRIPTION	REVISED	DATE
A	PDR NO: S170527-1A	Springwu	2017.9.20

1. Ground pin contact first.

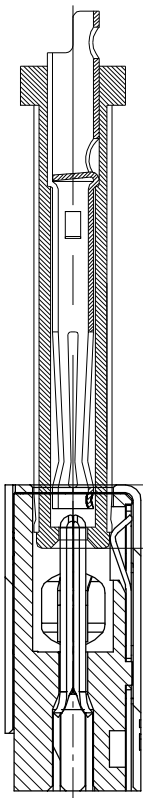

2. Positive pin contact.

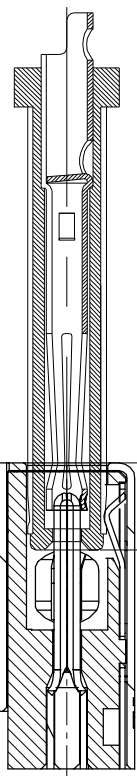

3. Lock position

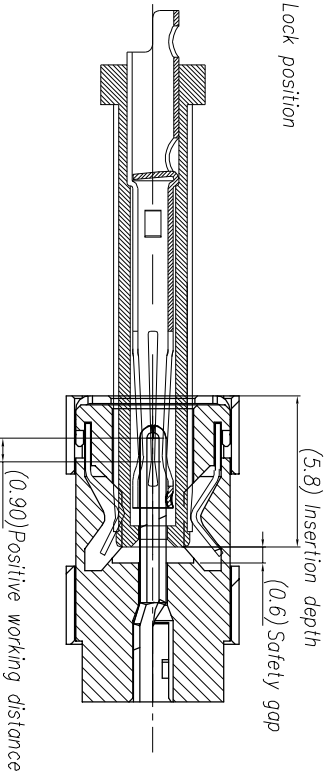

4. Full insertion

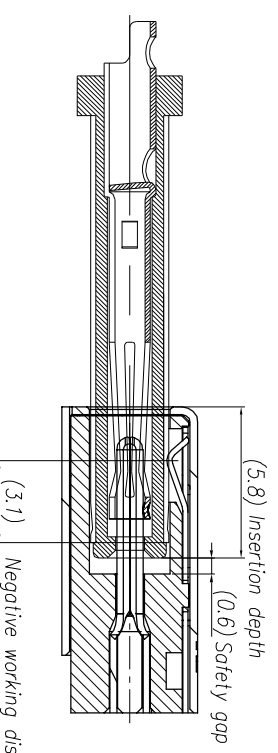
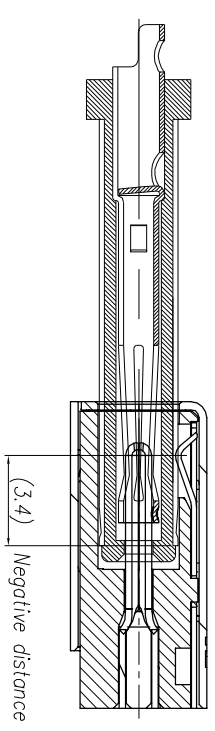
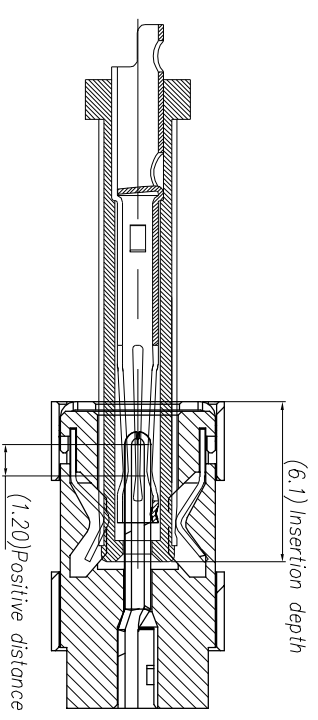

NO	DESCRIPTION	QTY	MATERIAL	PLATING & COLOR
UNLESS OTHERWISE SPECIFIED TOLERANCES				
 Singatron Enterprise Co., Ltd. 信音企業股份有限公司				
DC POWER JACK				
DECIMALS:		ANGLES:		
X	:±0.5	X	:±2°	
XX	:±0.3	XX	:±1°	
XXX	:±0.2			
TITLE		PART NO. 2DC3187-000111F		
DWM	Springwu	SCALE 5:1	UNIT: mm	
CHKD	Sky	SIZE: A3	SHEET: 2 OF 2	REV: A
APVD	Lussen	CUSTOMER COPY		