

REV.	ECN NO OR DESCRIPTION	REVISED	DATE
A	PDR NO: T210708-1A	Springwu	2022.02.22
B	ECN NO: S202212-C16	Springwu	2023.05.22
C	ECN NO: S202402-C03	Yizhou	2024.02.26

- SPECIFICATIONS:
- ELECTRICAL CHARACTERISTICS:
    - RATING: DC 20V 21A.
    - CONTACT RESISTANCE: 10mΩ MAX.(INITIAL)(ONLY FOR PIN+&SPRING-).  
CONTACT RESISTANCE: 30mΩ MAX.(INITIAL)(ONLY FOR DETECT).
    - DIELECTRIC WITHSTANDING VOLTAGE: 550V AC FOR ONE MINUTE.
    - INSULATION RESISTANCE: 100MΩ MIN. MEASURED BY 500 VDC.
  - MECHANICAL CHARACTERISTICS:
    - INSERTION FORCE: 0.8~3.0 Kgf (INITIAL&AFTER LIFE TEST).
    - WITHDRAWAL FORCE: 1.0~3.0 Kgf (INITIAL)  
0.8~3.0 Kgf (AFTER LIFE TEST).
  - LIFE TEST: 5,000 CYCLES.
  - OTHER GENERAL SPEC. TO REFER "2DC3215-003111F SPEC".
  - TO CONFORM TO SINGATRON HAZARDOUS SUBSTANCE FREE SPEC.
  - HALOGEN FREE PRODUCT IDENTIFICATION MARK ON JACK: Ⓞ
  - HALOGEN FREE PRODUCT IDENTIFICATION LABEL ON PACKAGING: Ⓞ
  - FOR IR REFLOW SOLDERING LEAD-FREE PROCESS.

Note: plug must fully mated with cover, any different shape must get approval from ID

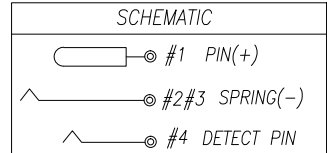
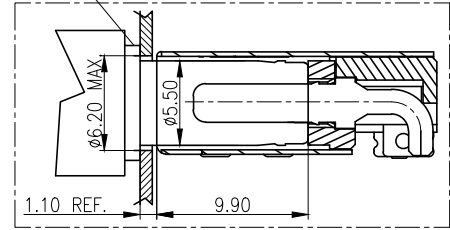

NO	DESCRIPTION	QTY	MATERIAL	PLATING & COLOR
F	SHIELDING	1	STAINLESS 0.3T	
E	DETECT PIN	1	OPPER ALLOY 0.2T	Ni 60u" Min..
D	SPRING(-)	1	COPPER ALLOY 0.25T	GOLD FLASH OVER Ni 60u" Min..
C	PIN(+)	1	BRASS	
B	BODY BASE	1	HIGH TEMP.THERMOPLASTIC (HALOGEN FREE)UL 94V-0	BLACK
A	BODY TOP	1		

UNLESS OTHERWISE SPECIFIED TOLERANCES		Singatron Enterprise Co., Ltd. 信音企業股份有限公司	
DECIMALS:	ANGLES:	TITLE: DC POWER JACK	
X :±0.5	X :±2°	DWN	Yizhou PART NO. 2DC3215-003111F
X.X :±0.3	X.X :±1°	CHKD	Boye SCALE 4:1 UNIT: mm
X.XX :±0.2		APVD	Liao SIZE: A3 SHEET: 1 OF 2 REV: C
<b>CUSTOMER COPY</b>			

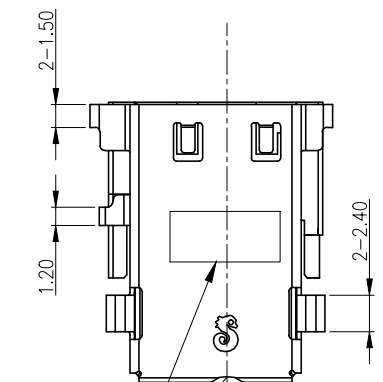

DATE CODE AREA  
YYMMDD OR YMD  
Y:YEAR  
M:MONTH  
D:DAY

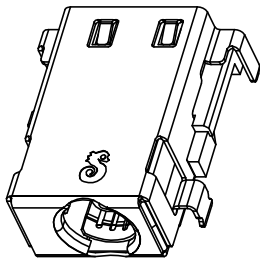

3D VIEW

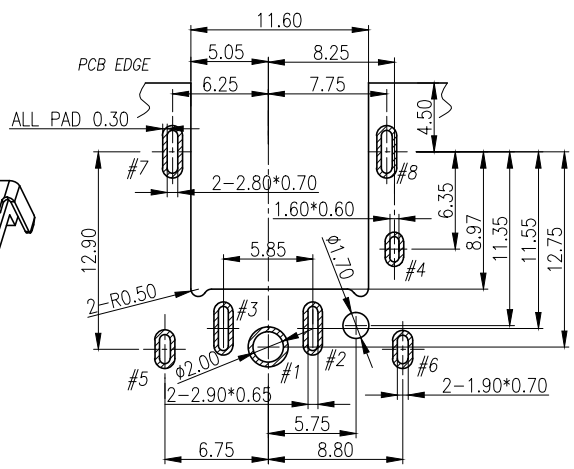

RECOMMENDED P.C.B LAYOUT  
TOP VIEW (Tolerance:±0.05)

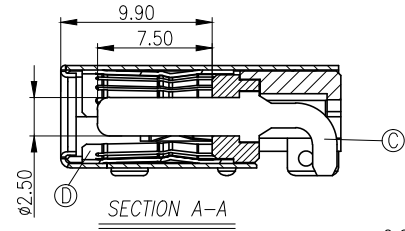
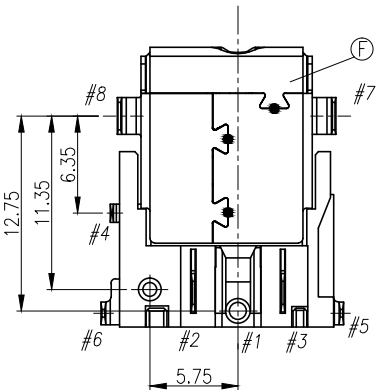
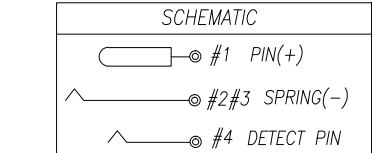
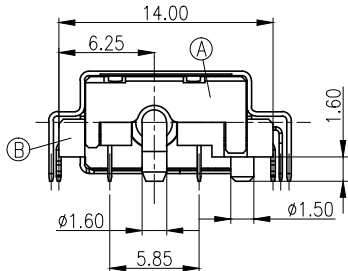
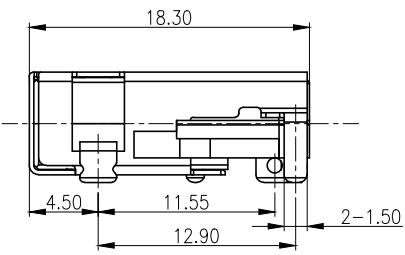
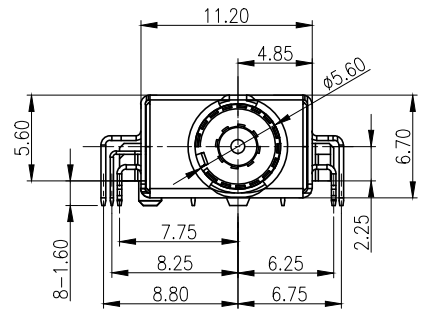

SECTION A-A

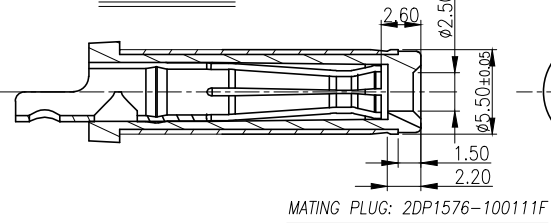

MATING PLUG: 2DP1576-100111F



REV.	ECN NO OR DESCRIPTION	REVISED	DATE
A	PDR NO: T210708-1A	Springwu	2022.02.22
B	ECN NO: S202212-C16	Springwu	2023.05.22
C	ECN NO: S202402-C03	Yizhou	2024.02.26

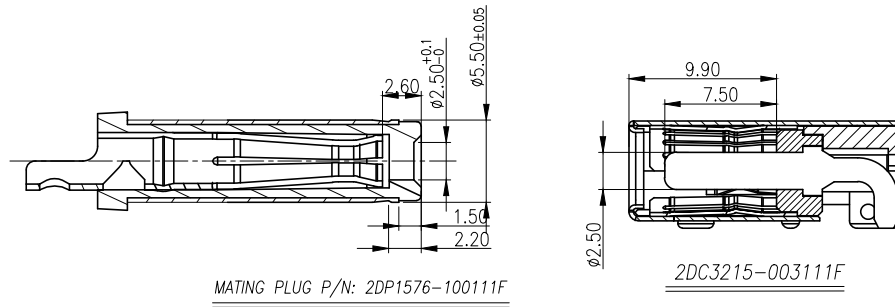

4. LOCK POSITION

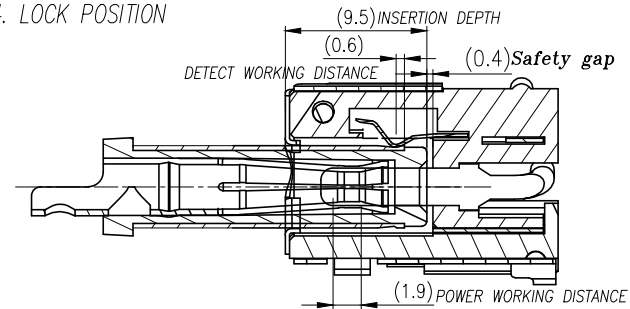

1. NEGATIVE CONTACT

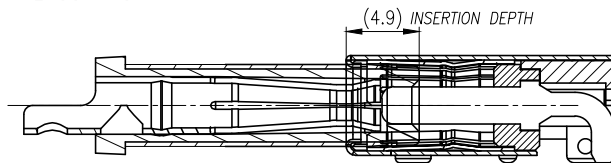

5. FULL INSERTION

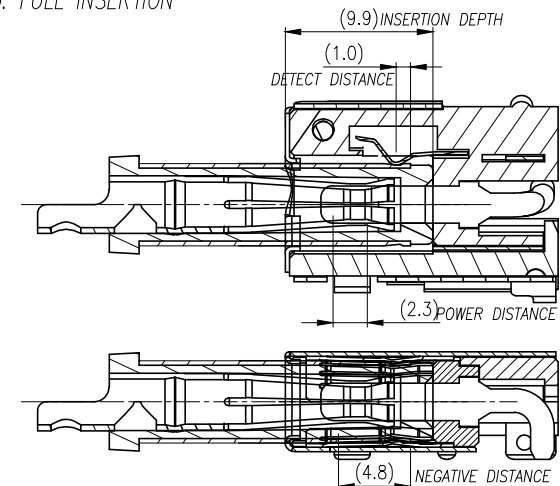

2. POWER PIN(+) CONTACT

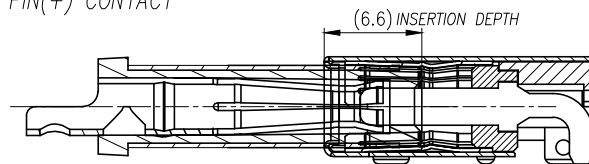

3. DETECT PIN CONTACT

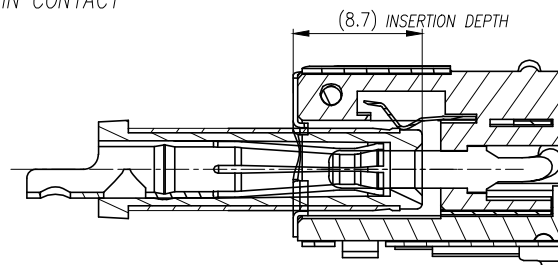

NO	DESCRIPTION	QTY	MATERIAL	PLATING & COLOR
UNLESS OTHERWISE SPECIFIED TOLERANCES			Singatron Enterprise Co., Ltd. 信音企業股份有限公司	
DECIMALS:	ANGLES:	TITLE	MATING DRAWING	
X :±0.5	X :±2°	DWN Yizhou	PART NO. 2DC3215-003111F	
X.X :±0.3	X.X :±1°	CHKD Boye	SCALE 4:1	UNIT: mm
X.XX :±0.2		APVD Liao	SIZE: A3	SHEET: 2 OF 2
REV: C				
CUSTOMER COPY				