

REV.	ECN NO OR DESCRIPTION	REVISED	DATE
A	PDR NO: T210813-3A	JIE-FU	2022.03.02

SPECIFICATIONS:

- ELECTRICAL CHARACTERISTICS:
 - RATING: DC 20V 20A.
 - CONTACT RESISTANCE: 10mΩ MAX.(INITIAL)(ONLY FOR PIN-&SPRING-). CONTACT RESISTANCE: 30mΩ MAX.(INITIAL)(ONLY FOR DETECT).
 - DIELECTRIC WITHSTANDING VOLTAGE: 550V AC FOR ONE MINUTE.
 - INSULATION RESISTANCE: 100MΩ MIN. MEASURED BY 500 VDC
- MECHANICAL CHARACTERISTICS:
 - INSERTION FORCE: 0.8~3.0 KgF (INITIAL&AFTER LIFE TEST).
 - WITHDRAWAL FORCE: 0.8~3.0 KgF (INITIAL&AFTER LIFE TEST).
- LIFE TEST: 5,000 CYCLES.
- OTHER GENERAL SPEC. TO REFER "2DC3215-003111F SPEC".
- TO CONFORM TO SINGATRON HAZARDOUS SUBSTANCE FREE SPEC.
- HALOGEN FREE PRODUCT IDENTIFICATION MARK ON JACK: Ⓞ
- HALOGEN FREE PRODUCT IDENTIFICATION LABEL ON PACKAGING: Ⓞ
- FOR IR REFLOW SOLDERING LEAD-FREE PROCESS.

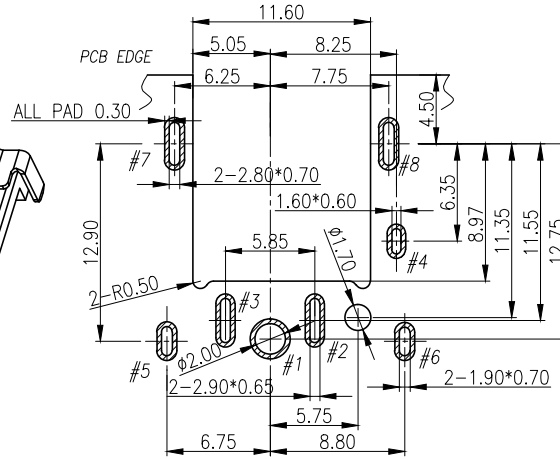
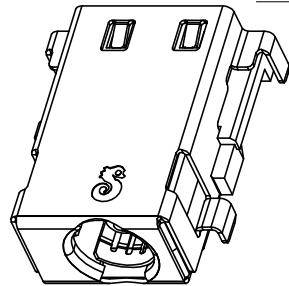
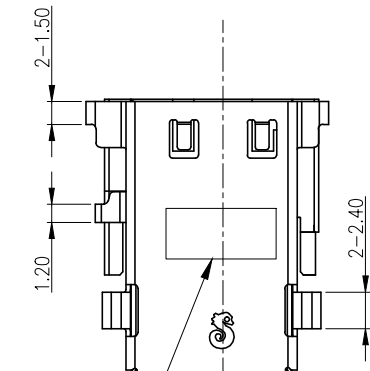

Note: plug must fully mated with cover, any different shape must get approval from ID

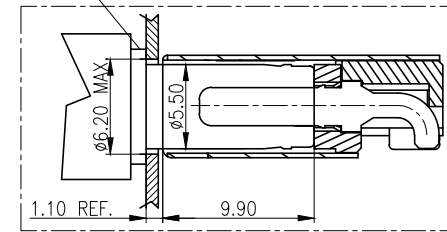

SCHEMATIC

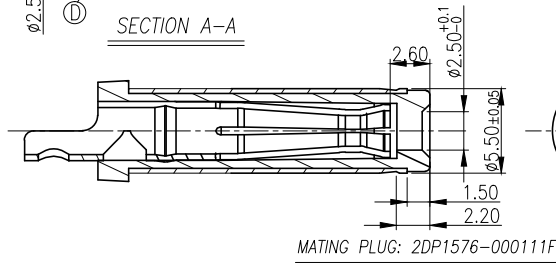
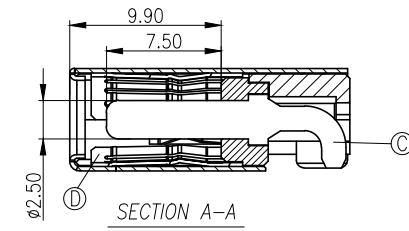
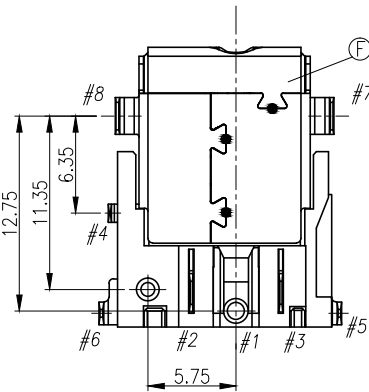
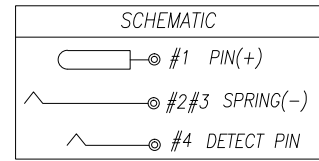
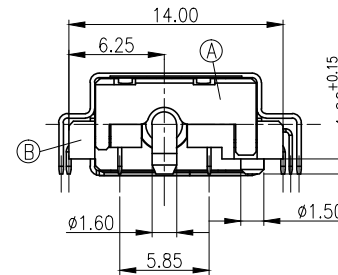
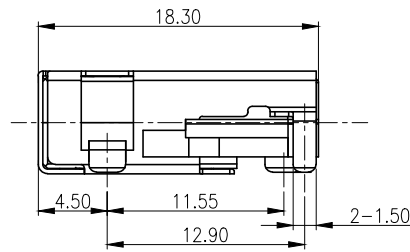
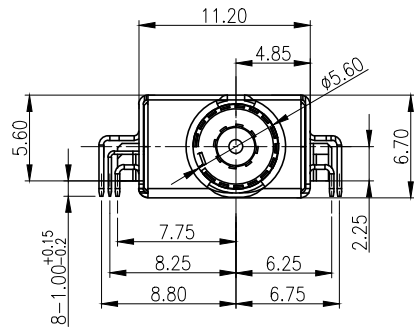
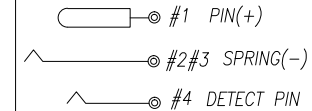

F	SHIELDING	1	STAINLESS 0.3T	
E	DETECT PIN	1	OPPER ALLOY 0.2T	Ni 60u" Min..
D	SPRING(-)	1	COPPER ALLOY 0.25T	
C	PIN(+)	1	BRASS	GOLD FLASH OVER Ni 60u" Min..
B	BODY BASE	1	HIGH TEMP.THERMOPLASTIC	
A	BODY TOP	1	(HALOGEN FREE)UL 94V-0	BLACK
NO	DESCRIPTION	QTY	MATERIAL	PLATING & COLOR
UNLESS OTHERWISE SPECIFIED TOLERANCES			Singatron Enterprise Co., Ltd. 信音企業股份有限公司	
DECIMALS:		ANGLES:		TITLE
X	:±0.5	X	:±2°	DC POWER JACK
X.X	:±0.3	X.X	:±1°	DWN JIE-FU PART NO. 2DC3215-005111F
X.XX	:±0.2			CHKD LUSSEN SCALE 4:1 UNIT: mm
				APVD LIAO SIZE: A3 SHEET: 1 OF 2 REV: A
CUSTOMER COPY				

REV.	ECN NO OR DESCRIPTION	REVISED	DATE
A	PDR NO: T210813-3A	JIE-FU	2022.03.02

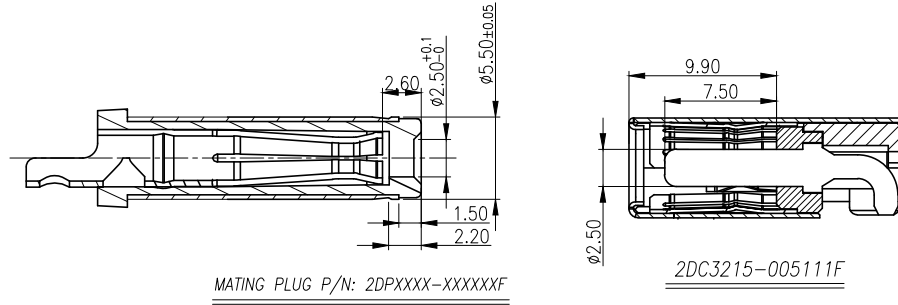

4. LOCK POSITION

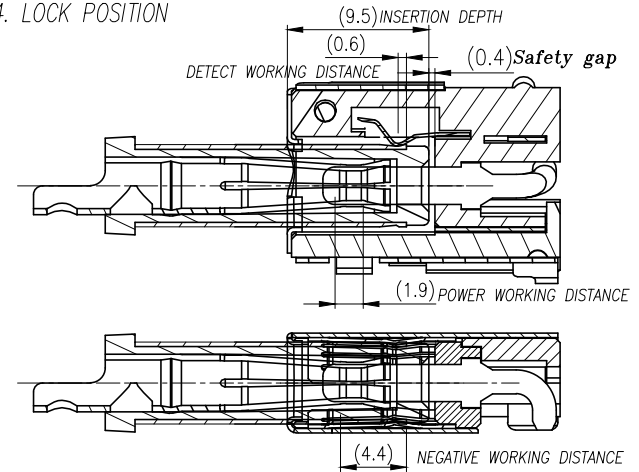

1. NEGATIVE CONTACT

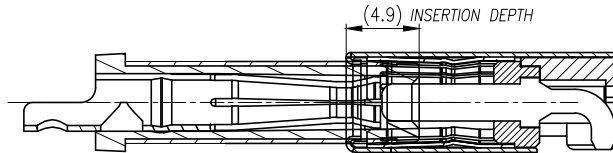

2. POWER PIN(+) CONTACT

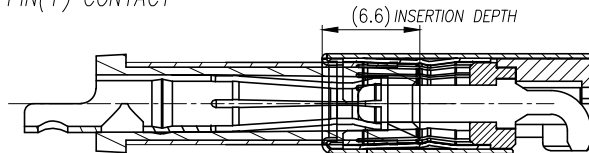

3. DETECT PIN CONTACT

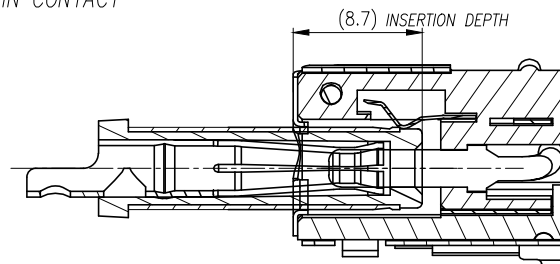

5. FULL INSERTION

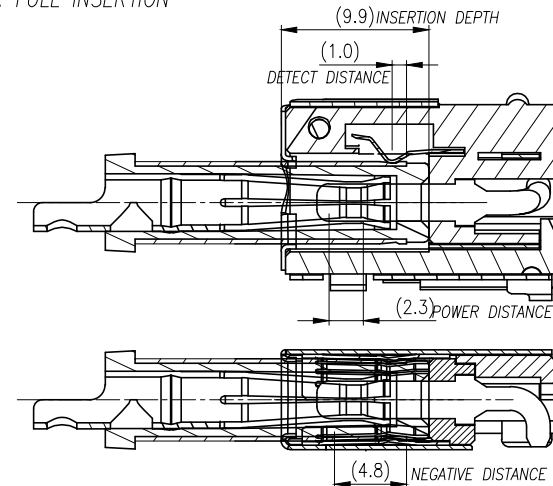

NO	DESCRIPTION	QTY	MATERIAL	PLATING & COLOR
UNLESS OTHERWISE SPECIFIED TOLERANCES		Singatron Enterprise Co., Ltd. 信音企業股份有限公司		
DECIMALS:	ANGLES:	TITLE	MATING DRAWING	
X :±0.5	X :±2°	DWN	JIE-FU	PART NO. 2DC3215-005111F
X.X :±0.3	X.X :±1°	CHKD	LUSSEN	SCALE 4:1 UNIT: mm
X.XX :±0.2		APVD	LIAO	SIZE: A3 SHEET:2 OF 2 REV:A
CUSTOMER COPY				