

DC JACK INSERT DEPTH

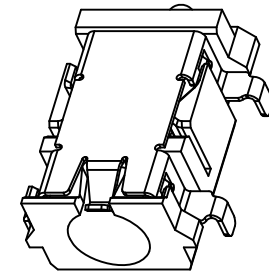

3D VIEW

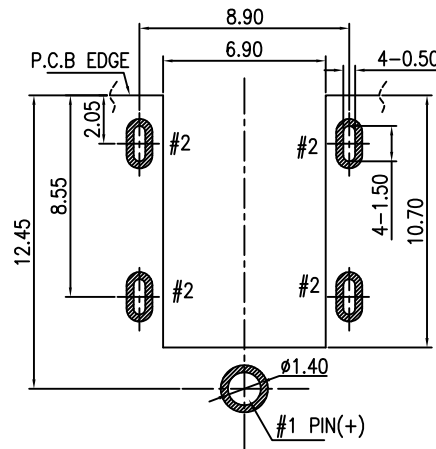
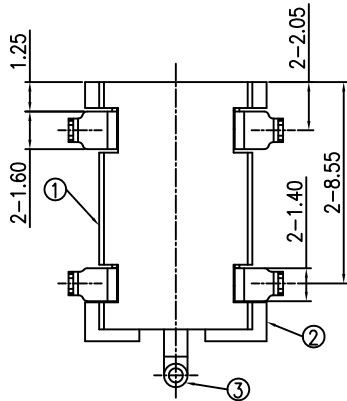

RECOMMENDED PCB LAYOUT

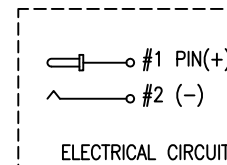

ELECTRICAL CIRCUIT

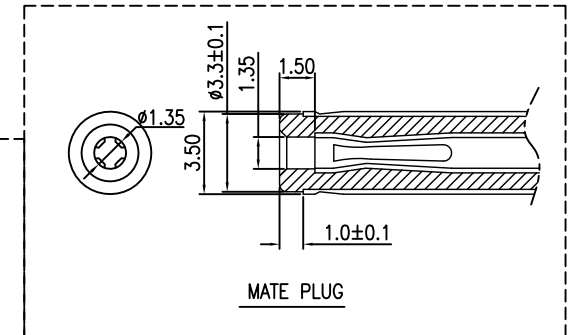

MATE PLUG

SPECIFICATIONS:

1. ELECTRICAL CHARACTERISTICS:

- 1-1. RATING: 24V 5A
- 1-2. CONTACT RESISTANCE: 30mΩ MAX.(INITIAL)
- 1-3. DIELECTRIC WITHSTANDING VOLTAGE: 500V AC FOR ONE MINUTE
- 1-4. INSULATION RESISTANCE: 100MΩ MIN. MEASURED BY 500V DC

2. MECHANICAL CHARACTERISTICS:

- 2-1. INSERTION FORCE : 0.3~3.0 KGF
- 2-2. WITHDRAWAL FORCE : 0.3~3.0 KGF

3. LIFE TEST: 5,000 CYCLES MIN.

4. FOR REFLOW SOLDERING LEAD-FREE PROCESS.

NO.	DESCRIPTION	QTY	MATERIAL	PLATING & COLOR
③	CENTER PIN	1	C3604 ϕ 1.3	Au
②	TERMINAL	1	C5210 0.2t	Au
①	HOUSING	1	P9PT	Black

UNLESS OTHERWISE SPECIFIED TOLERANCES

DECIMALS:		ANGLES:	
DIM	TOL	DIM	TOL
X.	\pm 0.50	X.	\pm 2°
X.X	\pm 0.30	X.X	\pm 1°
X.XX	\pm 0.20	X.XX	
X.XXX	\pm 0.10	X.XXX	

Singatron Enterprise Co., Ltd.

TITLE	ϕ 3.5 沉板式 DC POWER JACK		
DWN	Tony	PART NO.	2DC350135-0515300H
CHKD	2018.7.12	SCALE 1:1	UNIT: mm
APVD	Andy-liu	SIZE: A3	SHEET: 1 OF 2
		REV: A	

CUSTOMER COPY

1

2

3

4

5

6

7

8

F

F

E

E

D

D

C

C

B

B

A

A

1载带=1000PCS
 1外箱=1000PCSX10盘载带=10000PCS

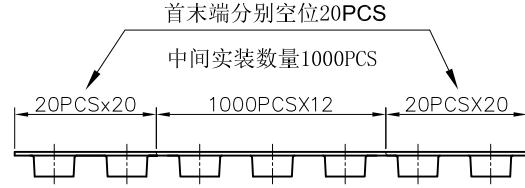

载带引出方向
 * 载带包装时请依此引出方向为标准

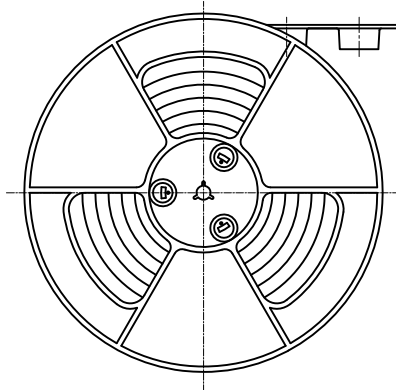

卷盘包装示意

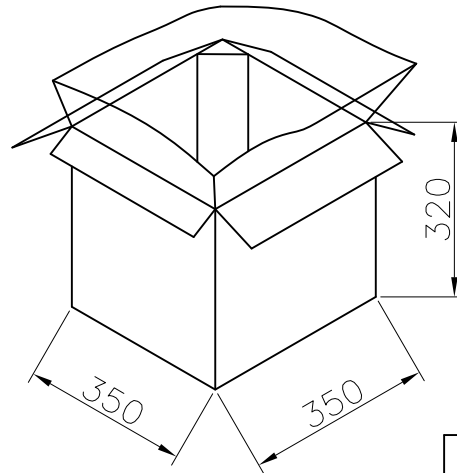
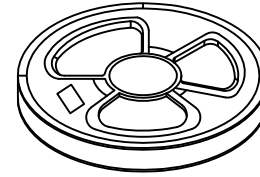
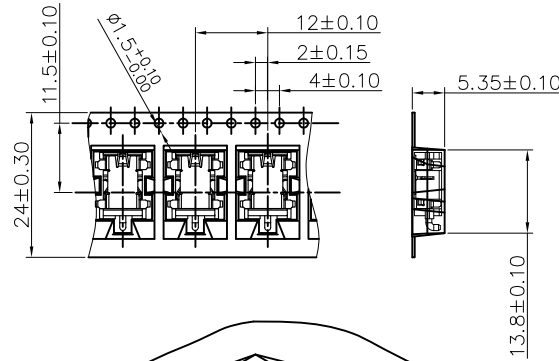

10KPCS/10卷/箱

UNLESS OTHERWISE SPECIFIED TOLERANCES				Singatron Enterprise Co., Ltd.			
DECIMALS:		ANGLES:		TITLE	ø3.5 沉板式 DC POWER JACK-包装图		
DIM	TOL	DIM	TOL	DWN	Tony	PART NO.	2DC350135-0515300H
X.	±0.50	X.	±2°	CHKD	2018.7.12	SCALE 1:1	UNIT: mm
X.X	±0.30	X.X	±1°	APVD	Andy-liu	SIZE: A3	SHEET: 2 OF 2
X.XX	±0.20	X.XX		REV: A			
X.XXX	±0.10	X.XXX		CUSTOMER COPY			