

REV	EGN NO	OR DESCRIPTION	REVISED	DATE
A	PDR	NO:T130312-6A	Eileen	2013.06.05

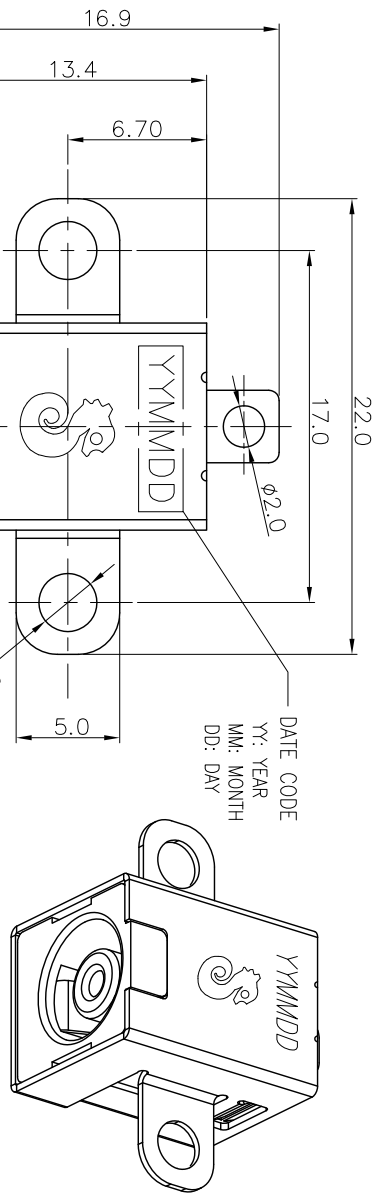

DATE CODE
 YY: YEAR
 MM: MONTH
 DD: DAY

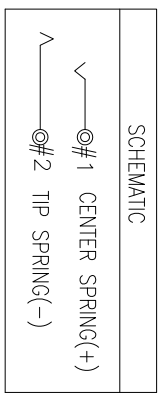
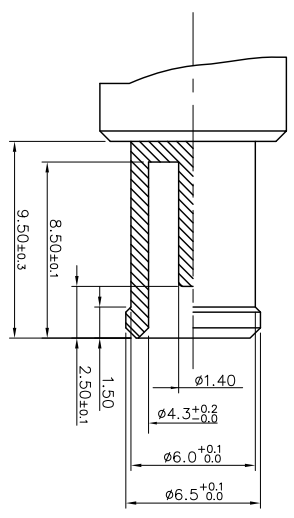
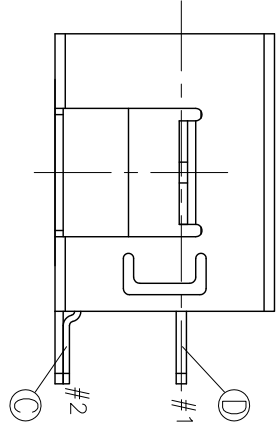
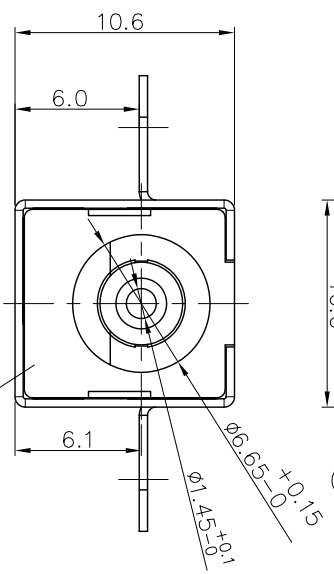

- SPECIFICATIONS:
- ELECTRICAL CHARACTERISTICS:
 - RATING: DC 20V 5A
 - CONTACT RESISTANCE: 30mΩ MAX. (INITIAL)
 - ELECTRIC WITHSTANDING VOLTAGE: 250V AC FOR ONE MINUTE.
 - INSULATION RESISTANCE: 100MΩ MIN. MEASURED BY 250V DC.
 - MECHANICAL CHARACTERISTICS:
 - INSERTION FORCE: 3.0kgf Max.
 - WITHDRAWAL FORCE: 1.0~3.0kgf (INITIAL), 0.5~3.0kgf (AFTER LIFE TEST).
 - LIFE TEST: 5000 CYCLES MIN.
 - OTHER GENERAL SPEC. TO REFER "2DC4002 SERIES SPEC".
 - TO CONFORM TO SINGATRON HAZARDOUS SUBSTANCE FREE SPEC.
 - HALOGEN FREE PRODUCT IDENTIFICATION MARK ON JACK:
 - HALOGEN FREE PRODUCT IDENTIFICATION LABEL ON PACKAGING:
 - PRINTED DATE CODE "YYMMDD" ON TOP OF CONNECTOR.
 - THE PANEL'S ID MUST BE GREATER THAN THE PLUG'S OD WHICH MUST HAVE A DIFFERENCE OF LESS THAN OR EQUAL TO 0.5 mm. (AS SHOWN IN FIGURE 1.)

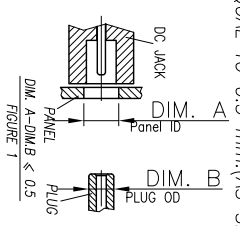

NO	DESCRIPTION	QTY	MATERIAL	PLATING & COLOR
D	CENTER SPRING	1	COPPER ALLOY 0.5t	GOLD FLASH ON CONTACT AREA SN 120μ" ON SOLDER TAIL ALL OVER Ni 50μ"
C	TIP SPRING	1	COPPER ALLOY 0.25t	GOLD FLASH ON CONTACT AREA SN 120μ" ON SOLDER TAIL ALL OVER Ni50μ"
B	SHELL	1	COPPER ALLOY 0.4t	Ni: 60 μ"
A	BODY	1	HIGH TEMP. PLASTIC UL94 V-0	BLACK

UNLESS OTHERWISE SPECIFIED TOLERANCES

DECIMALS:	ANGLES:
X : ±0.5	X : ±2°
X.X : ±0.3	X.X : ±1°
X.XX : ±0.2	

TITLE	DC POWER JACK
DWN	Eileen PART NO. 2DC4002-000006F
CHKD	Sky SCALE: 4:1 UNIT: mm
APVD	Lussen SIZE: A3 SHEET: 1 OF 1 REV: A

Singatron Enterprise Co., Ltd.
 信營企業股份有限公司

CUSTOMER COPY