

1 2 3 4 5 6 7 8

Notes:

- 1.Current Rating: 24V&5A max.
- 2.Contact Resistance: 50mOhms Max.(initial)
- 3.Insulation Resistance: 100M Ohms Min./500V DC
- 4.Dielectric Withstanding Voltage: 500V AC/1Minute
- 5.Mating Force: 35N Max, Withdrawal Force: 3N Min.
- 6.Durability: 5,000 Cycles
- 7.Operating Temperature:-25°C to+85°C

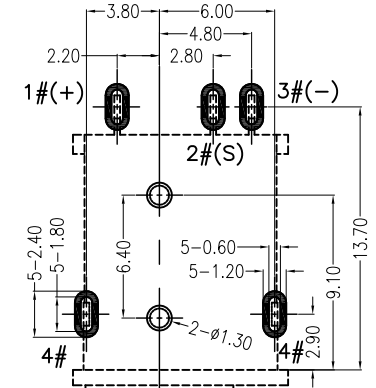
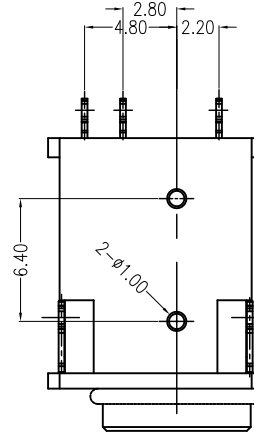
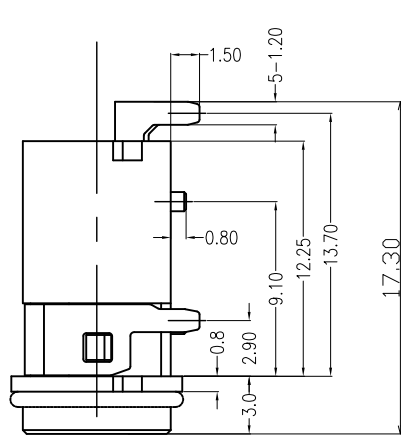
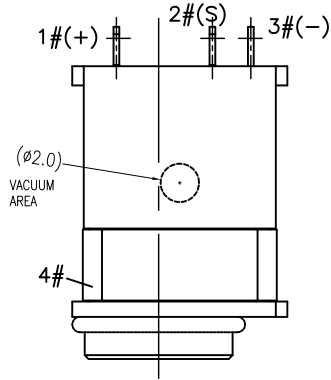
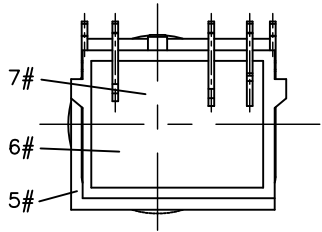

RECOMMEND PCB LAYOUT
TOLERANCE:±0.05

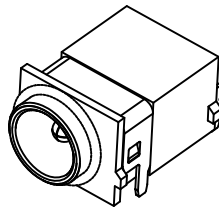
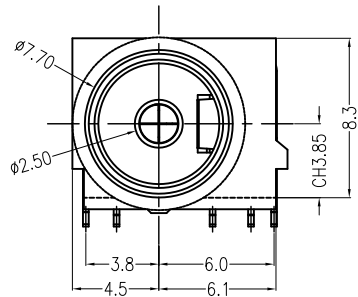
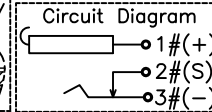
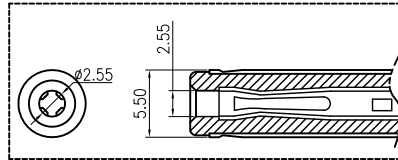
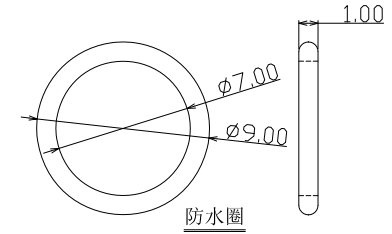

7	BOND	1	EPOXY; BLACK
6	BACK COVER	1	HIGH TEMPERATURE; BLACK
5	HOUSING	1	HIGH TEMPERATURE; BLACK
4	TERMINAL 4#	1	STAINLESS STEEL; NICKEL PLATING
3	TERMINAL 3#	1	COPPER ALLOY; NICKEL UNDER PLATING OVERALL, Sn PLATING ON SOLDER AREA, GOLD FLASH PLATING ON CONTACT AREA
2	TERMINAL 2#	1	COPPER ALLOY; NICKEL UNDER PLATING OVERALL, Sn PLATING ON SOLDER AREA, GOLD FLASH PLATING ON CONTACT AREA
1	CENTER PIN	1	COPPER ALLOY; NICKEL UNDER PLATING OVERALL, Sn PLATING ON SOLDER AREA, NI FLASH PLATING ON CONTACT AREA
ITEM	NAME	QTY	DESCRIPTION

UNLESS OTHERWISE SPECIFIED TOLERANCES

DECIMALS:		ANGLES:	
DIM	TOL	DIM	TOL
X.	±0.50	X.	±2°
X.X	±0.30	X.X	±1°
X.XX	±0.20	X.XX	///
X.XXX	±0.10	X.XXX	///

Singatron Enterprise Co., Ltd.

TITLE	DC POWER JACK 防水型		
DWN	Tony	PART NO.	2DC550250-1127W00H
CHKD	2022.5.10	SCALE 1:1	UNIT: mm
APVD	Andy	SIZE: A3	SHEET: 1 OF 1
		REV: A1	

CUSTOMER COPY

REV.	ECN NO.	DESCRIPTION	DESIGN	DATE
------	---------	-------------	--------	------

1 2 3 4 5 6 7 8