

REV.	ECN NO OR DESCRIPTION	REVISED	DATE
A	PDR RELEASE	IVY-C	2015.06.09

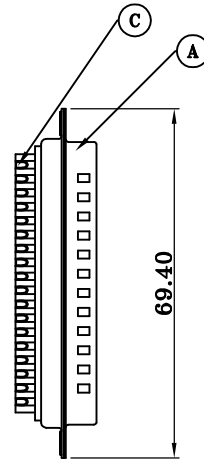

SPECIFICATIONS:

- ELECTRICAL CHARACTERISTICS:
  - CONTACT CURRENT RATING : 5.0 A
  - CONTACT RESISTANCE : 10 mΩ MAX.
  - DIELECTRIC WITHSTANDING VOLTAGE : 1000 V AC MIN.
  - INSULATION RESISTANCE : 5GΩ MIN.
- TEMPERATURE RATING: -55°C ~ +125°C
- OTHER GENERAL SPEC. TO REFER "2DS1607-000111H SPEC".
- TO CONFORM TO SINGATRON HAZARDOUS SUBSTANCE FREE SPEC.
- GREEN PRODUCT IDENTIFICATION LABEL ON PACKAGING: **G.P. PASS**
- PACKAGE: SEE "2DS1607-000111H" PACKAGE.

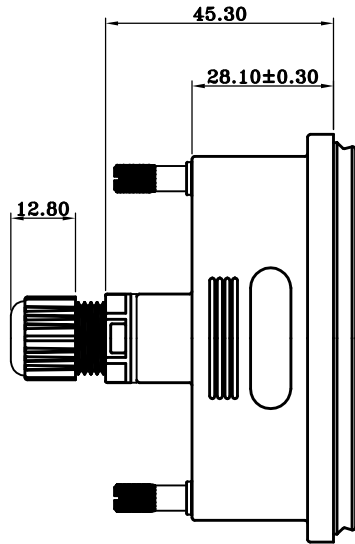
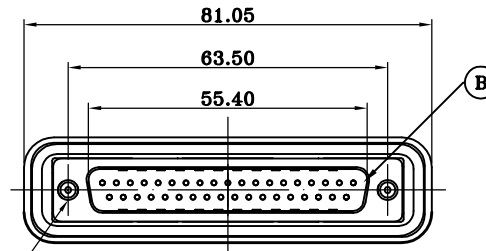
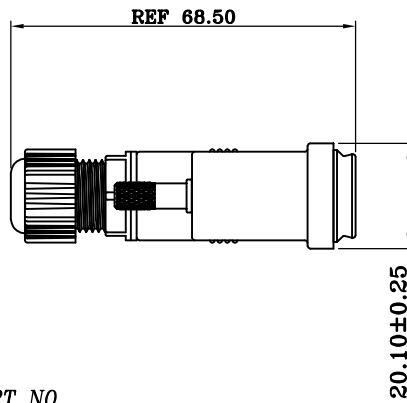

#4-40UNC

PART NO.  
2DS1607-000111H

- SUFFIX: HALOGEN FREE
- PACKAGE  
1: TRAY
- INSULATOR COLOR  
1: BLACK
- CONTACT PLATING  
1: GOLD FLASH

C	CONTACT	37	COPPER ALLOY	GOLD FLASH
B	INSULATOR	1	PBT UL 94V-0	BLACK
A	SHELL	1	STEEL MATERIA	NICKEL
NO	DESCRIPTION	QTY	MATERIAL	PLATING & COLOR
UNLESS OTHERWISE SPECIFIED TOLERANCES			Singatron Enterprise Co., Ltd. 信音企業股份有限公司	
DECIMALS:		ANGLES:		TITLE
X	:±0.5	X	:±2°	WATERPROOF D-SUB MALE 37PIN
X.X	:±0.3	X.X	:±1'	DWN
X.XX	:±0.2			IVY-C 2015.06.09
				CHKD
				ANGELA2015.06.09
				APVD
				ANGELA2015.06.09
				SCALE: 1:1
				UNIT: mm
				SIZE: A3
				SHEET: 1 OF 1
				REV: A

CUSTOMER COPY