

REV.	ECN NO OR DESCRIPTION	REVISED	DATE
A	PDR RELEASE	EVEN	2016.11.16

SPECIFICATION:

- 1-1.ELECTRICAL CHARACTERISTICS:
 1-1-1.CURRENT RATING: 3A.
 1-1-2.VOLTAGE RATING: 100V AC (RMS) CONTINUOUS MAX.
 1-1-3.CONTACT RESISTANCE:30 MILLIOHMS MAX.
 1-1-4.DIELECTRIC WITHSTANDING VOLTAGE:1000V AC RMS.
 1-1-5.INSULATION RESISTANCE: 1000MEGOHMS MIN. 500V DC.
- 1-2.MECHANICAL CHARACTERISTICS
 1-2-1 MATING FORCE: 5.1kgf MAX.
 1-2-2 UNMATING FORCE:1.0~4.0 Kgf
 1-2-3 SCREW RECEDE AND TWIST FORCE: 6.0kgf. min
- 1-3.ENVIRONMENT CHARACTERISTICS:
 OPERATING TEMPERATURE:-25°C TO +85°C
2. TO CONFORM TO THE SINGATRON HAZARDOUS SUBSTANCE FREE SPEC.
3. HALOGEN FREE PRODUCT IDENTIFICATION LABEL ON PACKAGING:
 4. 2DS1618-000111F PACKAGE: SEE "2DS1618-000111F PACKAGE."
 2DS1618-000112F PACKAGE: SEE "2DS1618-000112F PACKAGE."
 5. FOR WAVE SOLDERING LEAD-FREE PROCESS.
 6. OTHER GENERAL SPEC. TO REFER "2DS1618-000111XF SPEC".

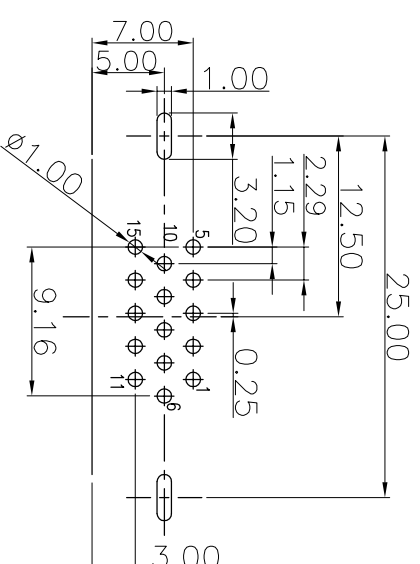
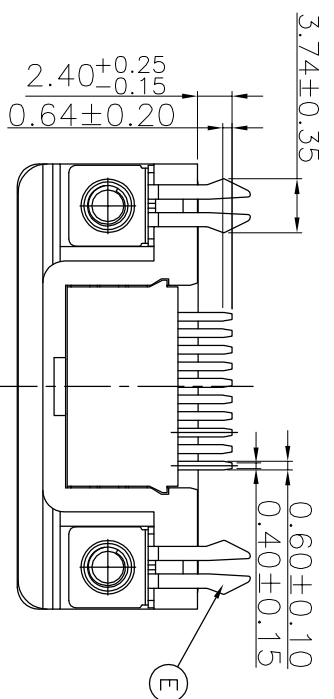
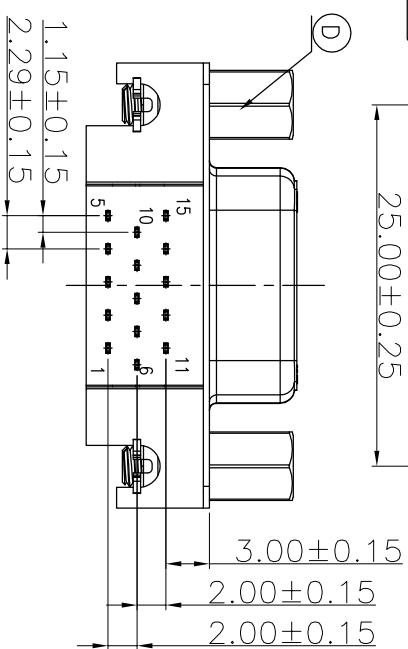
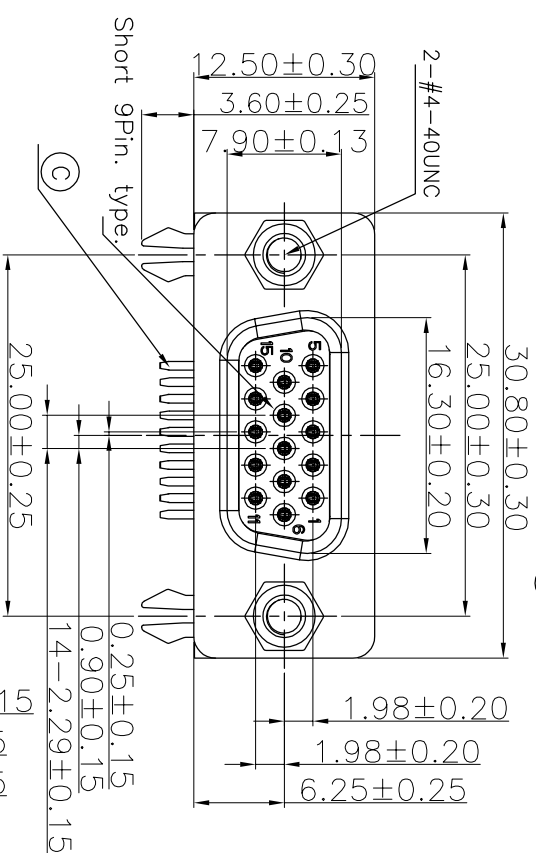
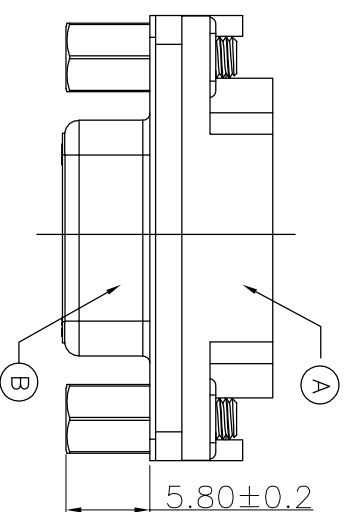
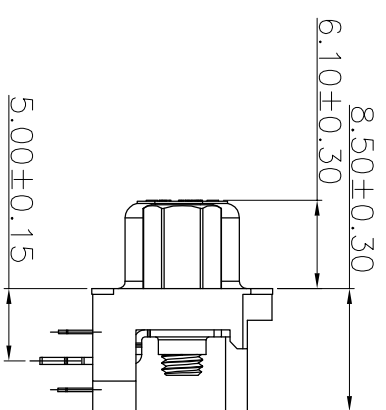
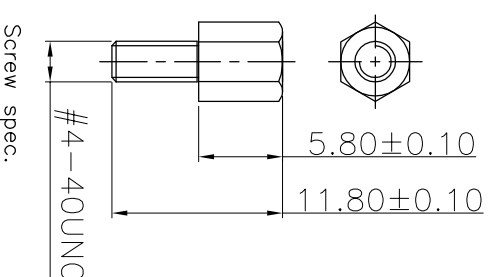

PART NO.
2DS1618-000111XF

SUFFIX: HALOGEN FREE

PACKAGE

1: TRAY

2: TAPE & REEL

HOUSING COLOR

1: BLUE

CONTACT PLATING

1: 80u" MIN. BRIGHT TIN PLATED OVERALL

NO	DESCRIPTION	QTY	MATERIAL	PLATING & COLOR
E	BOARD LOCKS	2	FERRORALLOY	TIN
D	SCREW	2	FERRORALLOY	NICKEL
C	TERMINAL	15	C2680	SEE PART NO.
B	FRONT SHELL	2	SPCC	NICKEL
A	HOUSING	1	PBT UL 94V-0	BLUE(661C)
NO	DESCRIPTION	QTY	MATERIAL	PLATING & COLOR

UNLESS OTHERWISE SPECIFIED TOLERANCES

Singatron Enterprise Co., Ltd.
信音企業股份有限公司

TITLE	D-SUB Connector
DECIMALS:	ANGLES:
X : ±0.5	X : ±2°
X.X : ±0.3	X.X : ±1°
X.XX : ±0.2	

APVD	ANGEL	SCALE	SIZE	SHEET	REV.
ANGEL2016.11.16	1:1	A3	1 OF 1	A	

CUSTOMER COPY