

REV.	ECN NO OR DESCRIPTION	REVISED	DATE
A	NEW RELEASE	LY	2013.05.10
B	ECN:C150119 Modify drawing	Longjiang	2016.02.29

SPECIFICATIONS:

- ELECTRICAL CHARACTERISTICS:
 - RATING: 240V AC MAX. 1A .
 - CONTACT RESISTANCE: 30mΩ MAX.
 - INSULATION RESISTANCE: 1,000 MEGAOHMS MIN. BY 500V DC.
 - DIELECTRIC WITHSTANDING VOLTAGE: 500V AC FOR 1 MINUTE.
- MECHANICAL CHARACTERISTICS:
 - INSERTION FORCE :4.5 KGF MAX.
 - WITHDRAWAL FORCE :0.5 KGF MIN.
- LIFE TEST: 5,000 CYCLES MIN.
- OTHER GENERAL SPEC. TO REFER "2DS2Y38 SERIES SPEC".
- INTERMATEABLE WITH STANDARD H/D 15P.MALE D-SUB.
- HALOGEN FREE PRODUCT IDENTIFICATION LABEL ON PACKAGING: 
- FOR REFLOW SOLDERING LEAD-FREE PROCESS.

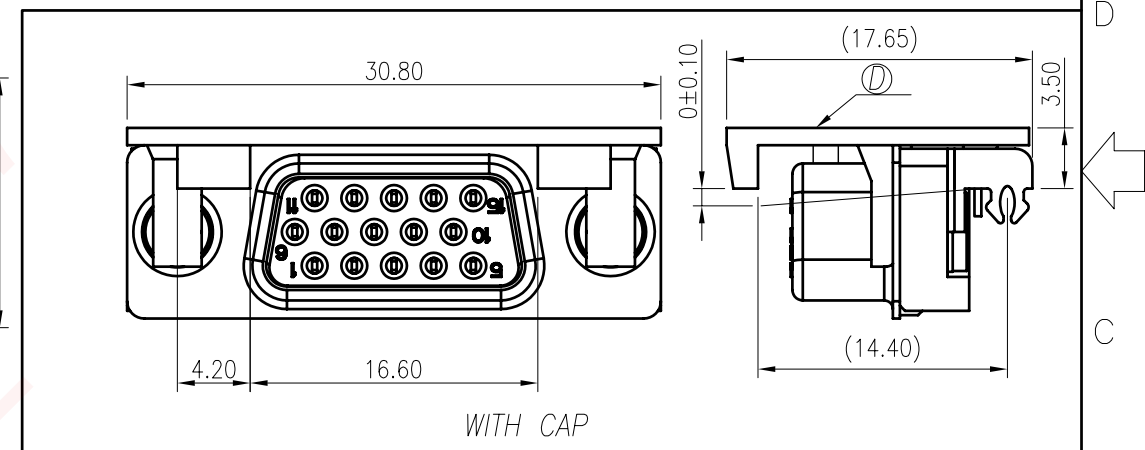

F	RIVET	2	METAL	NICKEL PLATING
E	FORK	2	METAL	MATTE TIN PLATING
D	COVER	1	HIGH TEMP. THERMOPLASTIC UL 94V-0	BLACK
C	SHELL	1	STEEL	BLACK NICKEL PLATING
B	CONTACT	15	COPPER ALLOY	GOLD FLASH ON CONTACT AREA AND SN PLATING SOLDER TAIL ALL OVER NICKEL PLATING
A	HOUSING	1	HIGH TEMP. THERMOPLASTIC UL 94V-0	BLACK
NO	DESCRIPTION	QTY	MATERIAL	PLATING & COLOR

UNLESS OTHERWISE SPECIFIED TOLERANCES		Singatron Enterprise Co., Ltd. 信音企業股份有限公司		
DECIMALS:	ANGLES:	TITLE	D-SUB 15 PIN CONNECTOR	
X :±0.5	X :±2°	DWN	Longjiang-Cao 16/03/17	PART NO. 2DS2Y38-000111F
X.X :±0.3	X.X :±1°	CHKD	Yan-Zhang 16/03/17	SCALE A:1 UNIT: mm
X.XX :±0.2		APVD	Justin-Kuo 16/03/17	SIZE: A3 SHEET:1 OF 1 REV: B
CUSTOMER COPY				

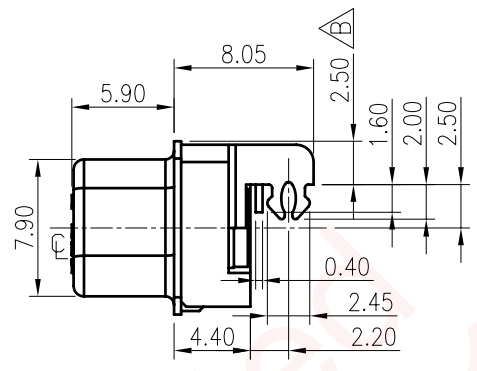
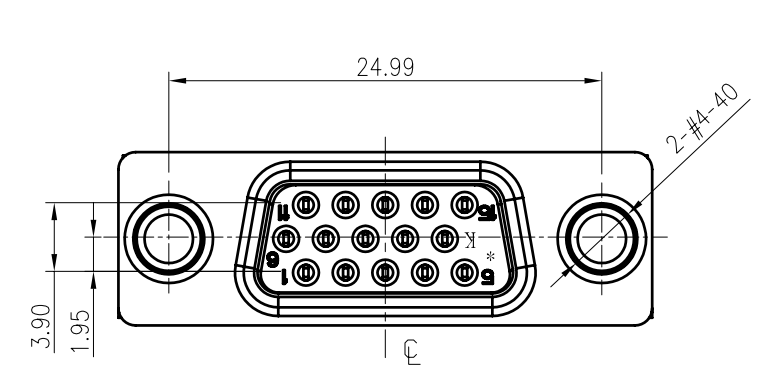

/// CAP STAND OFF ▨ PRODUCT STAND OFF

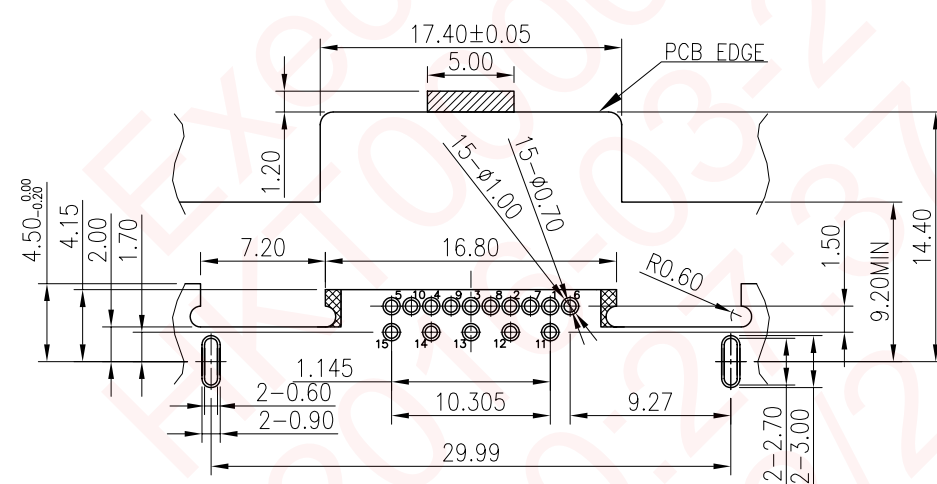

RECOMMENDED P.C.B LAYOUT THICKNESS=1.20mm
(TOP VIEW. TOL±0.05)

