

REV.	ECN NO. OR DESCRIPTION	REVISED	DATE
A	PRODUCT RELEASE	Longjiang	2017.06.22
B	ECN NO: C190107 DIMENSIONS CHANGE	SHUNZHONG	2019.01.15

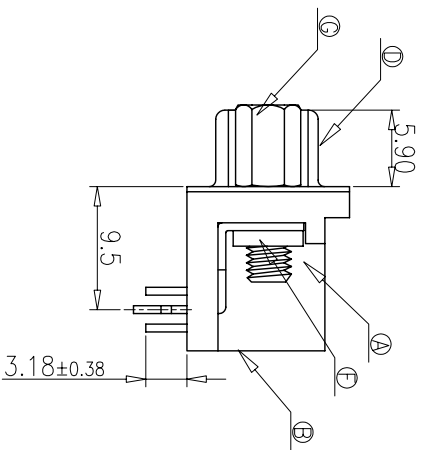

- SPECIFICATIONS:**
- ELECTRICAL CHARACTERISTICS:**
    - 1-1. RATING: 3A MAX.
    - 1-2. CONTACT RESISTANCE: 30 mΩ MAX. FOR INITIAL, 50 mΩ MAX. AFTER 1,500 CYCLES.
    - 1-3. INSULATION RESISTANCE: 1,000 MΩ MIN. AT 500V DC.
    - 1-4. DIELECTRIC WITHSTANDING VOLTAGE: 500V AC FOR ONE MINUTE.
  - MECHANICAL CHARACTERISTICS:**
    - 2-1. INSERTION FORCE :4.5 KGF MAX.
    - 2-2. WITHDRAWAL FORCE :0.5 KGF MIN.
  - LIFE TEST:** 1,500 CYCLES MIN.
  - OTHER GENERAL SPEC.** TO REFER "2DS2Y45-000111H SPEC".
  - GREEN PRODUCT IDENTIFICATION MARK ON PRODUCT:**
  - GREEN PRODUCT IDENTIFICATION LABEL ON PACKAGING:**
  - TO CONFORM TO SINGATRON HAZARDOUS SUBSTANCE FREE SPEC.**
  - FOR WAVE SOLDERING LEAD-FREE PROCESS.**

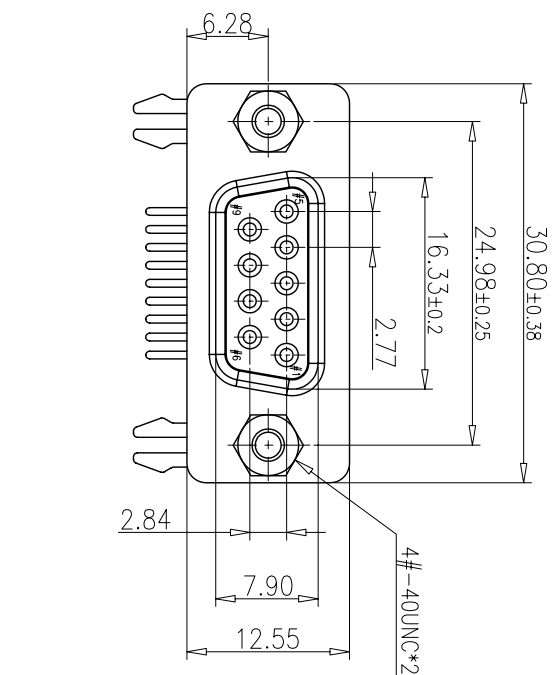
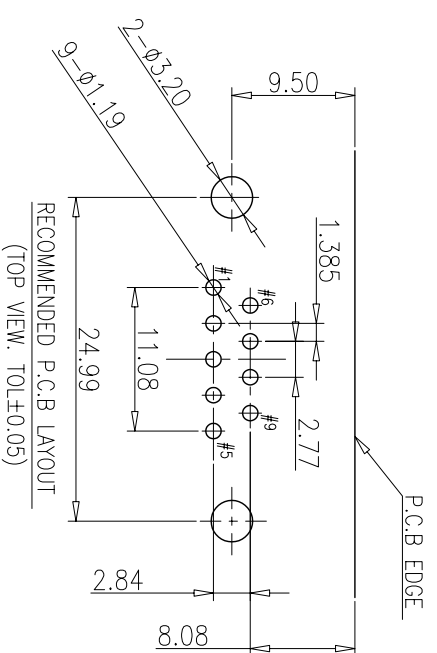
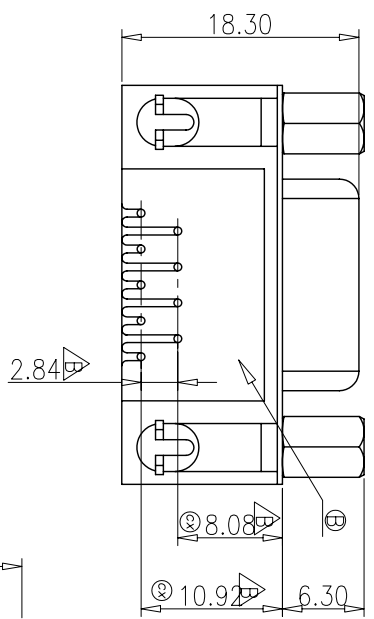

G	NUT	2	BRASS	NICKEL PLATING
F	RVET	2	BRASS	NICKEL PLATING
E	BOARD LOCK	2	SPCC	TIN PLATING
D	SHELL	1	SPCC	NICKEL PLATING
C	CONTACT	9	BRASS	GOLD FLASH ON CONTACT AREA TIN PLATING ON SOLDER TAIL ALL OVER NICKEL PLATING
B	COVER	1		BLACK
A	HOUSING	1	PBT UL 94V-0	
NO	DESCRIPTION	QTY	MATERIAL	PLATING & COLOR

UNLESS OTHERWISE SPECIFIED TOLERANCES

Singatron Enterprise Co., Ltd.  
信音企業股份有限公司

DECIMALS:	ANGLES:	TITLE
X :±0.5	X :±2°	D-SUB 9 PIN FEMALE CONNECTOR
X.X :±0.3	X.X :±1°	Shunzhong-Yuan 19/01/18
X.XX :±0.2		Stone-Zhu 19/01/18
		CHKD 19/01/18
		APVD 19/01/18

CUSTOMER COPY