

REV.	ECN NO OR DESCRIPTION	REVISED	DATE
A	PDR NO.:T130827-1A	JF	2014.01.24

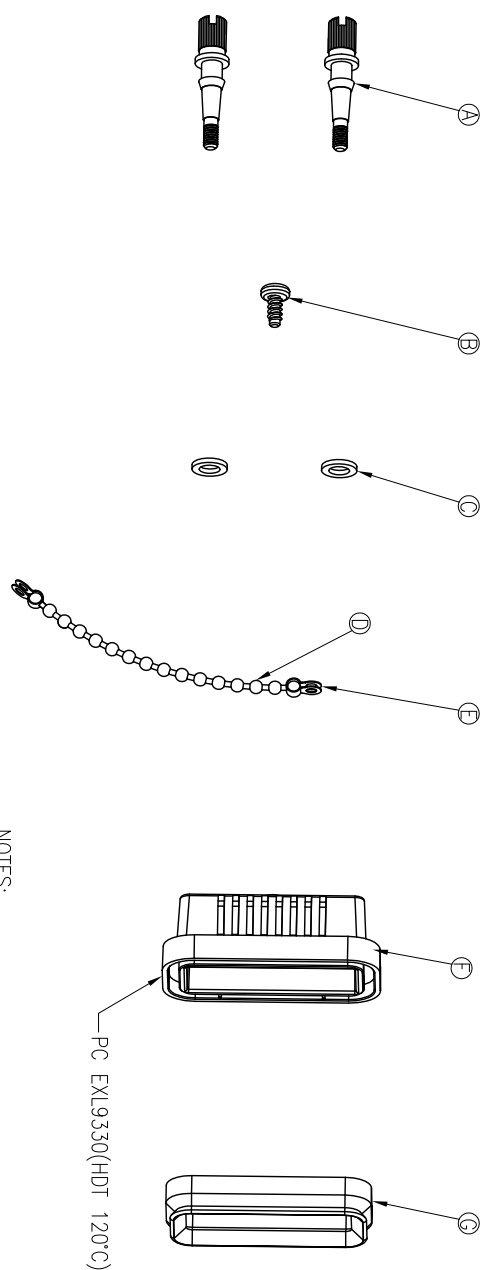

- NOTES:
1. WATERPROOF RATE: IP67
  2. SPECIFICATIONS:SEE "D-SUB SERIES SPECIFICATIONS".
  3. OPERATING TEMPERATURE: -40°C TO+80°C
  4. TO CONFORM TO SINGATRON HAZARDOUS SUBSTANCE FREE SPEC.
  5. GREEN PRODUCT IDENTIFICATION LABEL ON PACKAGING: **GR.PASS**

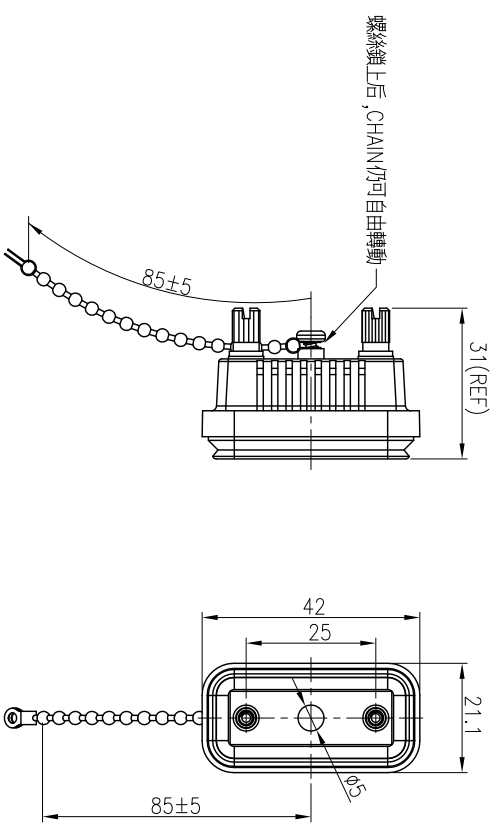

NO	DESCRIPTION	QTY	MATERIAL	PLATING & COLOR
G	GASKET	1	SILICONE	BLACK
F	HOUSING	1	PC 9330	BLACK
E	EARS	2	SUS 304	NATURAL
D	CHAIN	1	SUS 304	NATURAL
C	O-RING	2	SILICONE	GRAY
B	SCREW	1	STAINLESS STEEL	N/A
A	SCREW	2	SUS 304	N/A

UNLESS OTHERWISE SPECIFIED TOLERANCES

Singatron Enterprise Co., Ltd.  
信亨企業股份有限公司

DECIMALS:	ANGLES:	TITLE
X :±0.5	X :±2°	D-SUB 9 PIN WATERPROOF CAP
XX :±0.3	XX :±1°	DMN JF
XXX :±0.2		CHKD Harden
		APVD Quon

PART NO.2DS3000-W0902WH  
SCALE 1:1 UNIT: mm

SIZE: A3 SHEET:1 OF 1 REV: A

CUSTOMER COPY