

REV.	ECN NO. OR DESCRIPTION	REVISED	DATE
A	PDR NO.:S101221-6C	Glen	2011.06.15

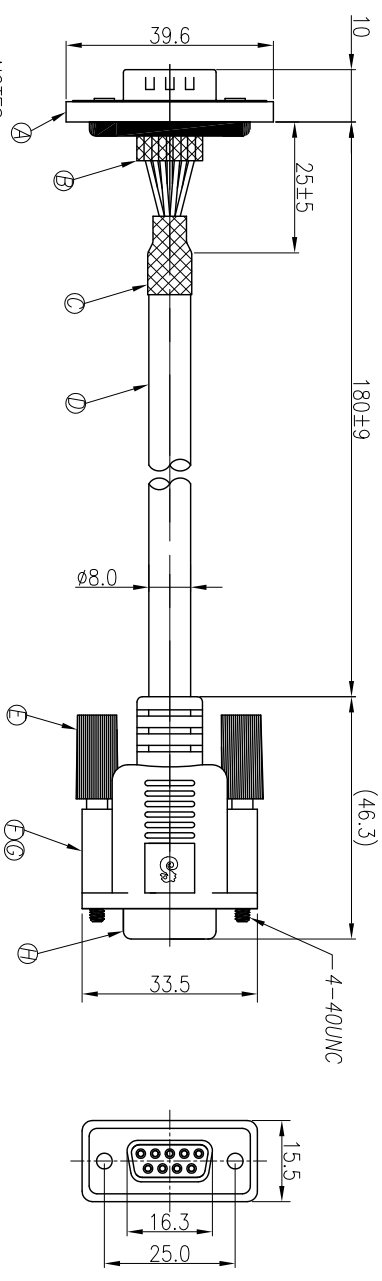

CONN. WATERPROOF RATE: IP67

NON-WATERPROOF

- NOTES:
1. WATERPROOF RATE: IP67(WHEN PROPERLY MATED)
 2. DO MATING TEST AFTER GLUED
 3. DIELECTRIC WITHSTANDING VOLTAGE: AC 1000 V R.M.S
 4. INSULATION RESISTANCE: 500 MEGOHMS MINIMUM AT DC 500V.
 5. CONTACT RESISTANCE: 25 MILLIOHMS MAXIMUM.
 6. OPERATING TEMPERATURE: -20°C TO+85°C.
 7. OTHER GENERAL SPEC. TO REFER "D-SUB SERIES SPEC".
 8. TO CONFORM TO SINGATRON HAZARDOUS SUBSTANCE FREE SPEC.
 9. GREEN PRODUCT IDENTIFICATION LABEL ON PACKAGING.
 10. FOR PANEL THICKNESS MAX OF 2.0mm

9	BLACK	9
8	RED	8
7	ORANGE	7
6	GREY	6
5	YELLOW	5
4	GREEN	4
3	WHITE	3
2	BLUE	2
1	BRONW	1
CONN.2		CONN.1
PIN OUT		

I	WATERPROOF CAP	1	P/N:2DS3000-W0900W	N/A
H	D-SUB 9 Pin Female Connector	1	PBT+BRASS	(1~3)u" GOLD PLATING OVER NICKEL PLATING
G	INNER MOLD	1	TPU	NATURAL
F	OVER MOLD	1	PVC	BLACK
E	SCREW	2	#4-40 4*23.5	NICKEL PLATING 100u"
D	CABLE	1	UL2464 22AWG*9C+CY AL/MT OD:8.0	BLACK(PVC JACKET)
C	SHRINK TUBE	1	ø10*15	BLACK
B	SHRINK TUBE	9	ø2.0*10	BLACK
A	MALE CONN	1	P/N:2DS3012-W09300	N/A
NO	DESCRIPTION	QTY	MATERIAL	PLATING & COLOR

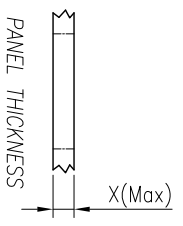

SCREW L=5.0 FOR PANEL THICKNESS UNDER 1.2mm
SCREW L=6.0 FOR PANEL THICKNESS BETWEEN 1.2~2.0mm

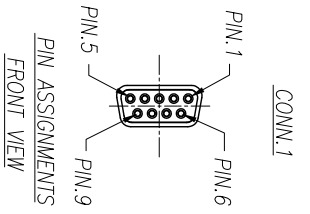
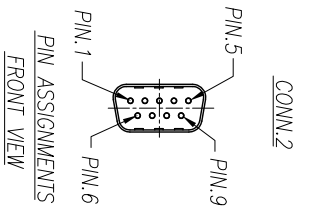
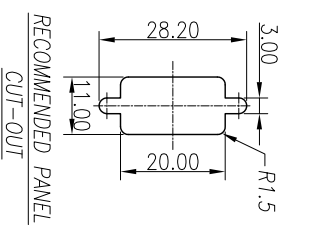

DECIMALS:	ANGLES:
X :±0.5	X :±2°
X.X :±0.3	X.X :±1°
X.XX :±0.2	

UNLESS OTHERWISE SPECIFIED TOLERANCES		Singatron Enterprise Co., Ltd. 信管企業股份有限公司	
TITLE	D-SUB 9 PIN CONN	SOLDER TYPE	
DWN	Glen	PART NO.2DS3012-W09303	
CHKD	Steve	SCALE 1:1	UNIT: mm
APVD	Tony	SIZE: A3	SHEET:1 OF 1
CUSTOMER COPY			

1 2 3 4 5 6 7 8