

REV.	ECN NO.	OR DESCRIPTION	REVISED	DATE
A	PDR NO.:S170517-3C	Wicky	2017.5.18	

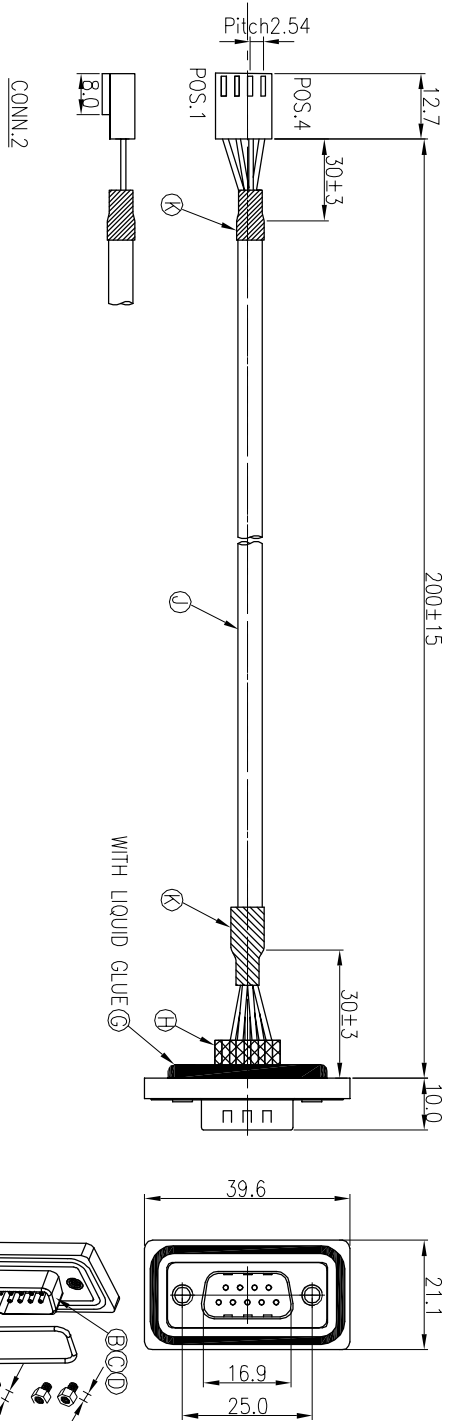
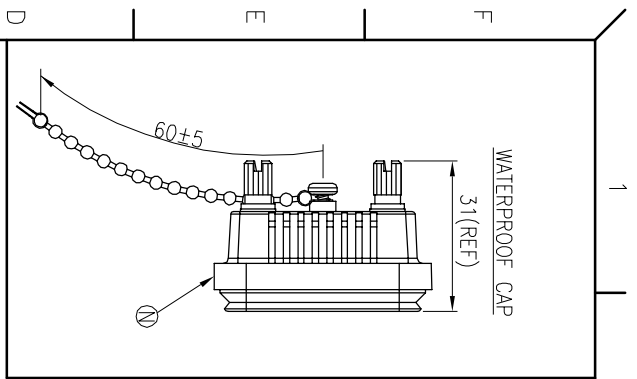

4	ORANGE	5
1	RED	9
2	BROWN	3
3	BLACK	2

CONN.2 WIRE COLOR

CONN.1

PIN OUT

- NOTES:
1. WATERPROOF RATE: IP67
 2. OPERATING TEMPERATURE: -40°C TO+80°C(PANEL).
 3. OTHER GENERAL SPEC. TO REFER "D-SUB SERIES SPEC".
 4. TO CONFORM TO SINGATRON HAZARDOUS SUBSTANCE FREE SPEC.
 5. GREEN PRODUCT IDENTIFICATION LABEL ON PACKAGING:
 6. FOR PANEL THICKNESS MAX OF 2.0mm

G.P. PASS

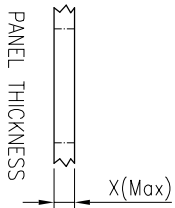
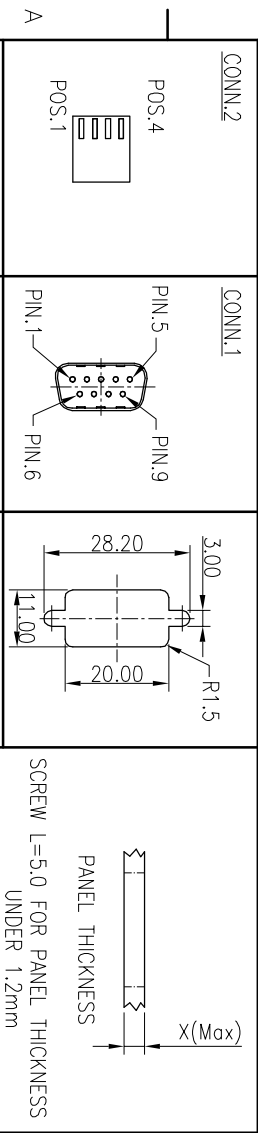

SCREW L=5.0 FOR PANEL THICKNESS UNDER 1.2mm
SCREW L=6.0 FOR PANEL THICKNESS BETWEEN 1.2~2.0mm

N	WATERPROOF CAP	1	P/N:2DS3000-W0900W	N/A
M	TERMINAL	4	PHOSPHOR BRONZE	TIN-PLATED
L	HOUSING	1	NYLON 66 UL 94V-0	WHITE
K	HEAT SHRINK TUBE	2	Ø6.0 L=20MM	BLACK
J	CABLE	1	UL2464 22AWG*4C,0D:5.0	BLACK
H	HEAT SHRINK TUBE	4	Ø1.5 L=10mm	BLACK
G	LIQUID GLUE	1	N/A	BLACK
F	SCREW	4	BRASS	N/A
E	O-RING	1	SILICON 94V-0	LIGHT BLUE
D	MALE PIN	9	BRASS	GOLD PLATED
C	SHELL	2	COLD ROLLER STEEL	NI PLATED
B	INSULATOR	2	PBT 94V-0	BLACK
A	BODY	1	PA66+30GF%	BLACK

UNLESS OTHERWISE SPECIFIED TOLERANCES

NO	DESCRIPTION	QTY	MATERIAL	PLATING & COLOR
A	BODY	1	PA66+30GF%	BLACK
B	INSULATOR	2	PBT 94V-0	BLACK
C	SHELL	2	COLD ROLLER STEEL	NI PLATED
D	MALE PIN	9	BRASS	GOLD PLATED
E	O-RING	1	SILICON 94V-0	LIGHT BLUE
F	SCREW	4	BRASS	N/A
G	LIQUID GLUE	1	N/A	BLACK
H	HEAT SHRINK TUBE	4	Ø1.5 L=10mm	BLACK
J	CABLE	1	UL2464 22AWG*4C,0D:5.0	BLACK
K	HEAT SHRINK TUBE	2	Ø6.0 L=20MM	BLACK
L	HOUSING	1	NYLON 66 UL 94V-0	WHITE
M	TERMINAL	4	PHOSPHOR BRONZE	TIN-PLATED
N	WATERPROOF CAP	1	P/N:2DS3000-W0900W	N/A

DECIMALS:	ANGLES:
X :±0.5	X :±2'
X.X :±0.3	X.X :±1'
X.XX :±0.2	

Singatron Enterprise Co., Ltd.
信譽企業股份有限公司

TITLE	D-SUB 9 PIN CONN SOLDER TYPE
DMW	Wicky
CHKD	Horlen
APVD	Steve

PART NO.2DS3012-W09309H
SCALE 1:1 UNIT: mm
SIZE: A3 SHEET: 1 OF 1
REV: A
CUSTOMER COPY