

REV.	ECN NO OR DESCRIPTION	REVISED	DATE
A	PDR NO.S11104-6A	LILY	2011.12.27

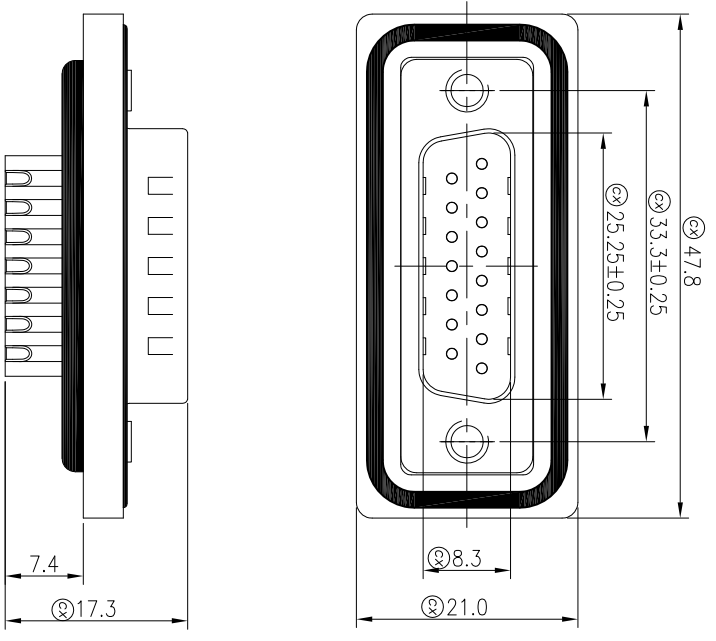

- NOTES:
1. WATERPROOF RATE: IP68(WHEN PROPERLY MATED)
IP68: IMMERSED IN 1M WATER FOR 24 HOURS
 2. DO MATING TEST AFTER GLUED
 3. DIELECTRIC WITHSTANDING VOLTAGE: AC 1000 V R.M.S
 4. INSULATION RESISTANCE: 5000 MEGOHMS MINIMUM,AT DC 500V.
 5. CONTACT RESISTANCE: 25 MILLIOHMS MAXIMUM.
 6. OPERATING TEMPERATURE: -20°C TO+105°C.
 7. OTHER GENERAL SPEC. TO REFER "D-SUB SERIES SPEC."
 8. TO CONFORM TO SINGATRON HAZARDOUS SUBSTANCE FREE SPEC.
 9. GREEN PRODUCT IDENTIFICATION LABEL ON PACKAGING: **G.P. PASS**
 10. ⊕REPRESENT CRITICAL DIMENSIONS.

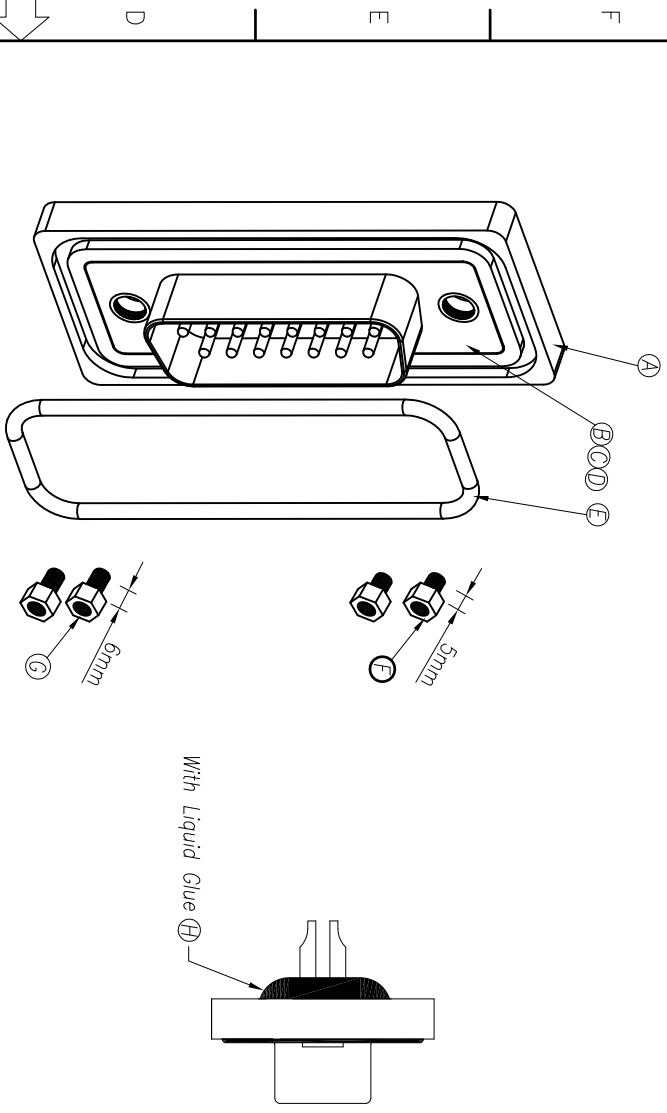
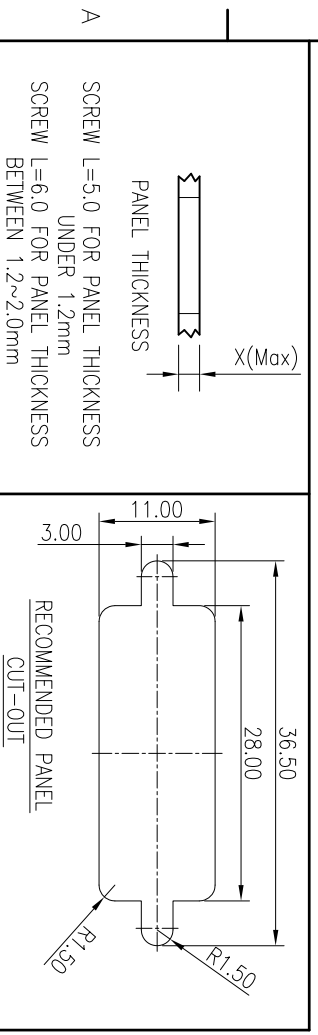

PANEL THICKNESS

SCREW L=5.0 FOR PANEL THICKNESS UNDER 1.2mm

SCREW L=6.0 FOR PANEL THICKNESS BETWEEN 1.2~2.0mm

H	LIQUID GLUE	1	N/A	BLACK
G	SCREW	2	BRASS L=6mm	NI PLATED 80U"
F	SCREW	2	BRASS L=5mm	NI PLATED 80U"
E	O-RING	1	SILICONE(SHORE 70°)	LIGHT BLUE
D	MALE PIN	15	Phosphor Bronze	GOLD PLATED
C	SHELL	2	COLD ROLLER STEEL	NI PLATED
B	INSULATOR	2	PBT	BLACK
A	D-SUB 15 PIN CORE	1	NNYLON+33%GF(70G33L)	BLACK
NO	DESCRIPTION	QTY	MATERIAL	PLATING & COLOR
UNLESS OTHERWISE SPECIFIED TOLERANCES				
Singatron Enterprise Co., Ltd. 信音企業股份有限公司				
DECIMALS:		ANGLES:	TITLE	
X	:±0.3	X	:±1°	D-SUB 15 PIN MALE CONN
X.X	:±0.2	X.X	:±0.5°	MALE PIN FOR SOLDER TYPE
X.XX	:±0.1			PART NO.2DS3012-W15300H
X.XXX	:±0.05			SCALE:1:1 UNIT: mm
				APVD Tony SIZE: A3 SHEET:1 OF 1 REV: A
ENGINEERING COPY				