

DATE CORÐ: YYMMDD
(YY=YEAR; MM=MONTH; DD=DAY)

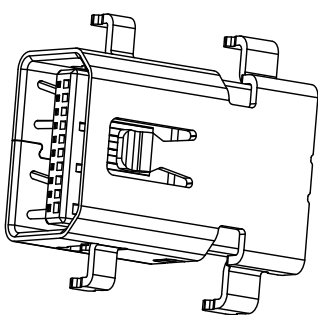

3D VIEW

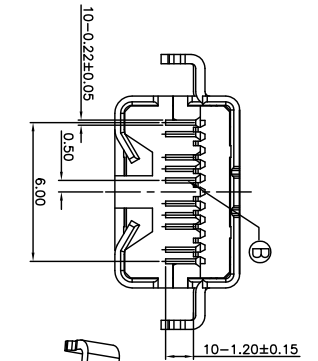
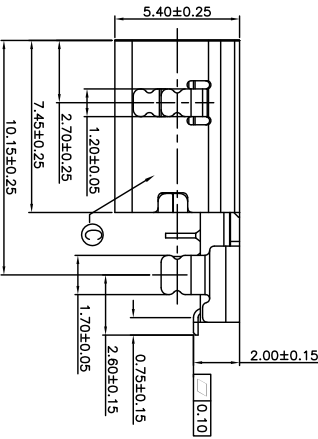
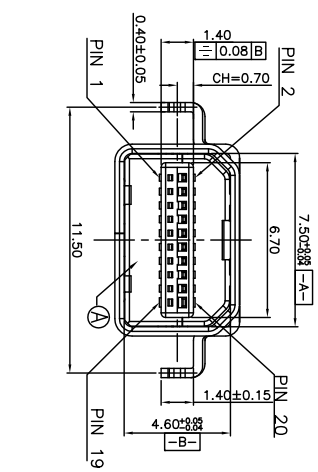
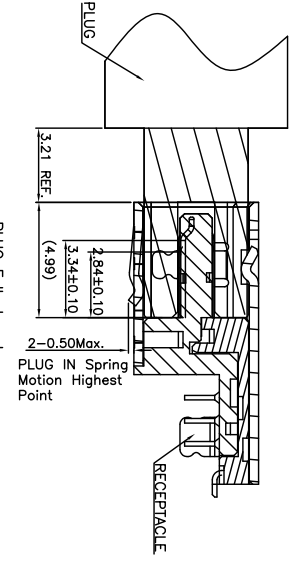
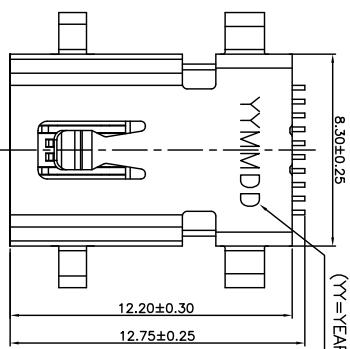
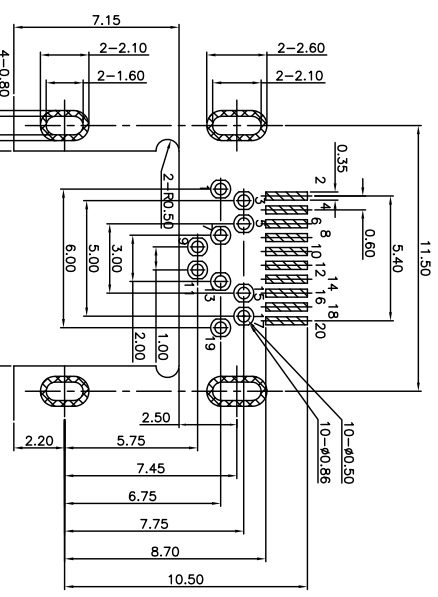
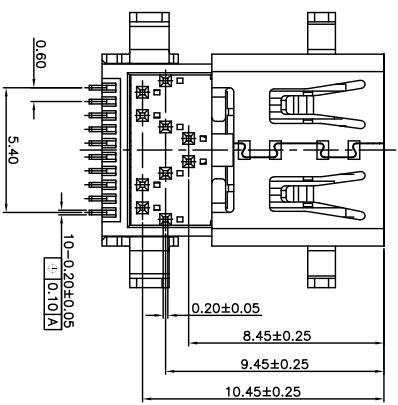

RECOMMENDED PCB LAYOUT(TOP VIEW)
(THICKNESS=1.60±0.05mm)
(TOLERANCE=±0.05mm)

SPECIFICATIONS:

1. TO CONFORM TO THE SINGATRON HAZARDOUS SUBSTANCE FREE SPEC.
2. HALOGEN FREE PRODUCT IDENTIFICATION LABEL ON PACKAGING.
3. PACKAGE: SEE "2D71533-000111F" PACKAGE.
4. FOR REFLOW SOLDERING LEAD-FREE PROCESS.
5. OTHER GENERAL SPEC. TO REFER "2D71533-000111F SPEC".

PART NO.
2D71533-000111F

- SUFFIX: HALOGEN FREE
- PACKAGE
- 1: TAPE AND REEL
- HOUSING COLOR
- 1: BLACK

- CONTACT PLATING
- 1: GOLD FLASH ON CONTACT AREA
- 60U" MIN. MATTE TIN PLATED ON SOLDER AREA,
- 40U" MIN. NICKEL UNDERPLATE OVER ALL.

PIN	SIGNAL TYPE	PIN NAME
1	GND	GND
2	In	Hot Plug Detect
3	Out	M.Lone 0 (g)
4	CONTRIC	CONTRIC
5	Out	M.Lone 0 (n)
6	CONTRIC (see note 1)	CONTRIC2
7	GND	GND
8	GND	GND
9	Out	M.Lone 1 (g)
10	Out	M.Lone 3 (g)
11	Out	M.Lone 1 (n)
12	Out	M.Lone 3 (n)
13	GND	GND
14	GND	GND
15	Out	M.Lone 2 (g)
16	I/O	AUX CH (g)
17	Out	M.Lone 2 (n)
18	I/O	AUX CH (n)
19	GND	GND
20	DR_PINS	DR_PINS

C	SHELL	1	SUS304	50U" MIN. BLACK NICKEL
B	CONTACT	20	C2680	SEE PART NO.
A	HOUSING	1	LCP UL 94V-0	BLACK
NO	DESCRIPTION	QTY	MATERIAL	PLATING & COLOR

UNLESS OTHERWISE SPECIFIED TOLERANCES

Singatron Enterprise Co., Ltd.
信登企業股份有限公司

TITLE: MINI DISPLAYPORT RECEPTACLE CONNECTOR

DWN: 2020/04/20
CHKD: 2020/04/20
APVD: 2020/04/20

PART NO. 2D71533-000111F
SCALE: 1/1 UNIT: mm
SIZE: A3 SHEET: 1 OF 1 REV: A

CUSTOMER COPY

REV./ECN NO. OR DESCRIPTION	REVISED	DATE
A PDR RELEASE	Even	2020/04/20