

REV.	ECN NO.	OR DESCRIPTION	REVISED	DATE
B	ECN NO: 950003		EVEN	2006.6.21

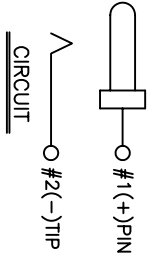

SPECIFICATIONS:

- 1.RATING: DC 19V 7A
- 2.INSERTION FORCE: 3.0Kgf Max.
- 3.WITHDRAWAL FORCE: 1.0Kg~3.0Kg
- 4.ADJACENT TERMINALS SHALL NOT BE LESS THAN 100 MEGOHMS BY 500 VOLTS MEGGER.
- 5.JACK SHALL WITHSTAND 500 VOLTS BETWEEN ANY ADJACENT TERMINAL FOR ONE MINUTE.
- 6.JACK CONTACT RESISTANCE SHALL NOT EXCEED 0.015 OHMS.
- 7.JACK SHALL WITHSTAND 5,000 CYCLES OF INSERTION AND WITHDRAWAL WITH TESTING PLUG, AND CONTACT RESISTANCE SHALL NOT EXCEED 0.015 OHMS.
- 7.MEASURING CONDITION:
TEMPERATURE: FROM 5°C TO 35°C.
RELATIVE HUMIDITY: FROM 40% TO 85%.
- 8.SOLDER HEAT RESISTANCE: WAVE SOLDERING 260°C 10SECS.
- 9.TO CONFORM TO THE "SE-01-001" & "ROHS DIRECTIVE"
- 10.GREEN PRODUCT IDENTIFICATION MARK IN JACK:
- 11.GREEN PRODUCT IDENTIFICATION LABEL IN PACKING: G.P. PASS
- 12.FOR WAVE SOLDERING LEAD-FREE PROCESS.
- 13.PRINTED DATE CODE "YYMMDD" ON TOP OF CONNECTOR.

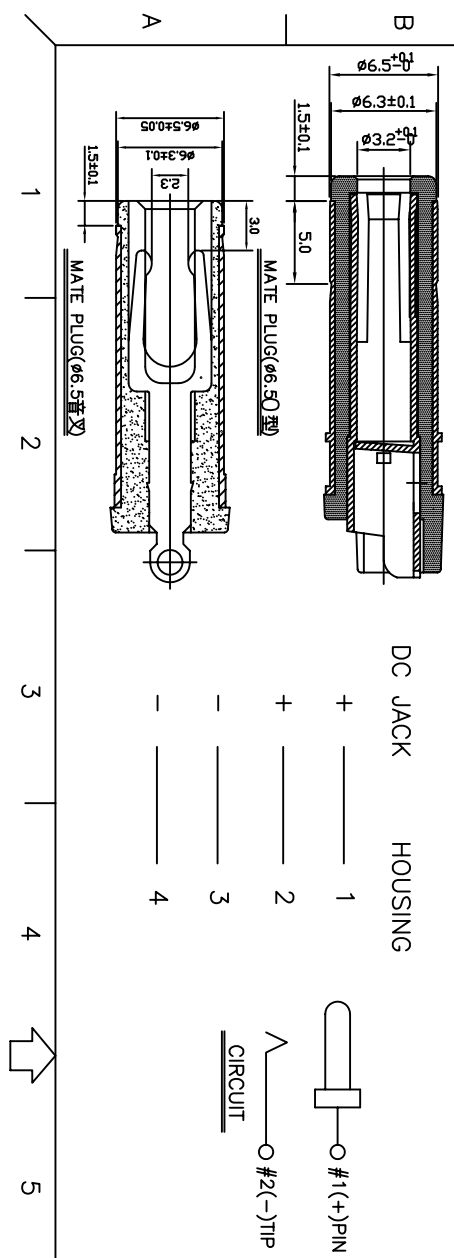
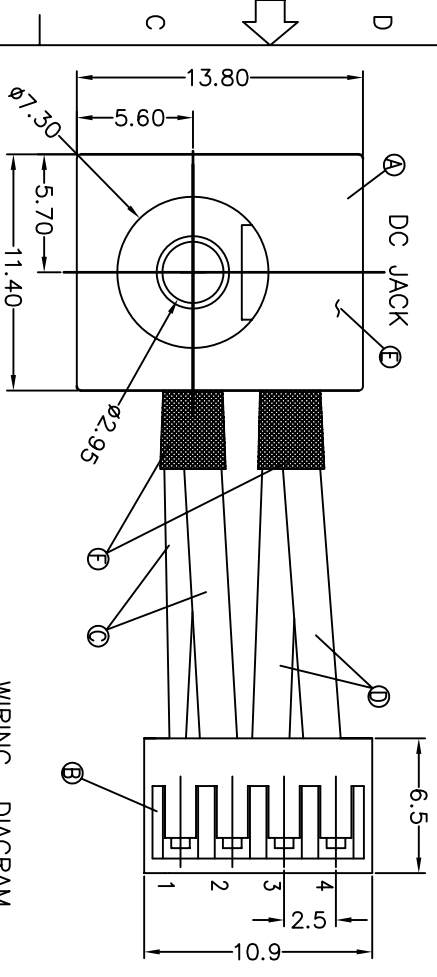
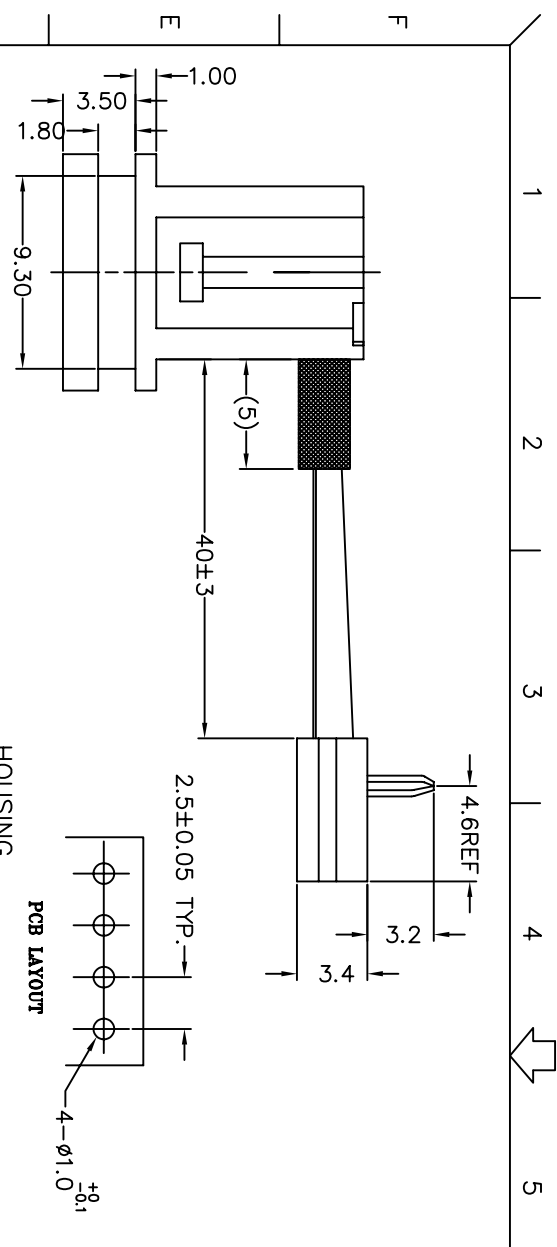
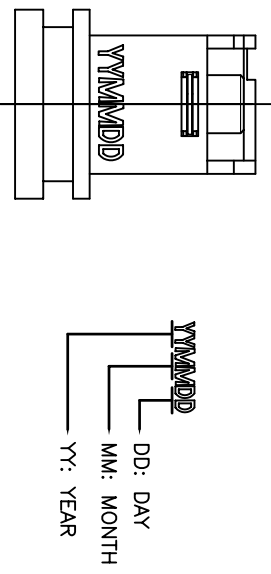

F	HEAT SHRINK TUBE	2	Ø3.5 L=10mm	BLACK COLOR
E	COVER	1	PBT UL94V-0	BLACK COLOR
D	WIRE	2	UL1430 22AWG	BLACK COLOR
C	WIRE	2	UL1430 22AWG	RED COLOR
B	HOUSING	1	Nylon UL94V-0	WHITE COLOR
A	DC JACK	1	SEE "SINGATRON P/N: 2DC-0057L100"	
NO	DESCRIPTION	QTY	MATERIAL	PLATING & COLOR
UNLESS OTHERWISE SPECIFIED TOLERANCES				
Singatron Enterprise Co., Ltd. 信登企業股份有限公司				
TITLE DC POWER JACK WITH WIRE				
DWN	DN 2006.6.21	PART NO.	2DW-0005-003	
CHKD	DN 2006.6.21	SCALE: 4/1	UNIT: mm	
APVD	DN 2006.6.21	SIZE: A3	SHEET: 1 OF 1	REV: B

CUSTOMER COPY