

REV.	ECN NO.	OR DESCRIPTION	REVISED	DATE
A	PDR NO: 20060804-4		Roy-yang	2007.2.24
B	ECN NO: S070212		Roy-yang	2007.2.26
C	ECN NO: S070807		Bill	2007.8.22
D	ECN NO: S070911		Bill	2007.9.22

SPECIFICATIONS:

- CONNECT(A)  
INSERTION FORCE: 3.0kg MAX. WITHDRAWAL FORCE: 1.0~3.0kg MIN.
- CONNECT(B)  
CONTACT RESISTANCE 20mΩ MAX.
- INSULATION RESISTANCE BETWEEN ANY ADJACENT TERMINALS SHALL NOT BE LESS THAN 100 MEGOHMS BY 500 VOLTS MEGGER.
- JACK SHALL WITHSTAND 250 VOLTS BETWEEN ANY ADJACENT TERMINAL FOR ONE MINUTE.
- CONTACT RESISTANCE SHALL NOT EXCEED 0.03 OHMS.
- JACK SHALL WITHSTAND 5,000 CYCLES OF INSERTION AND WITHDRAWAL WITH TESTING PLUG, AND CONTACT RESISTANCE SHALL NOT EXCEED 0.06 OHMS.
- MEASURING CONDITION:  
TEMPERATURE: FROM 5°C TO 35°C.  
RELATIVE HUMIDITY: FROM 40% TO 85%.
- ENVIRONMENTAL SPECIFICATIONS:  
7.1 HUMIDITY TEST: HUMIDITY 90% TO 95%; TEMPERATURE 40°C ±2°C FOR 96 HOURS.  
7.2 HEAT TEST: TEMPERATURE 70°C ± 2°C (HUMIDITY BELOW 50%) FOR 96 HOURS.  
7.3 COLD TEST: TEMPERATURE -40°C ± 2°C FOR 96 HOURS.
- RATING: DC 20V 7A 43uF AND DC 20V 10A 43uF DEPEND ON MATING PLUG DETAIL TYPE
- TO CONFORM TO THE 'SE-01-001' & 'THE EUROPEAN RESTRICTIONS-ON HAZARDOUS SUBSTANCES (ROHS) DIRECTIVE'  
11.GREEN PRODUCT IDENTIFICATION MARK IN JACK:  
12.GREEN PRODUCT IDENTIFICATION LABEL IN PACKING: G.P.PASS  
13.FOR LEAD FREE PROCESS.

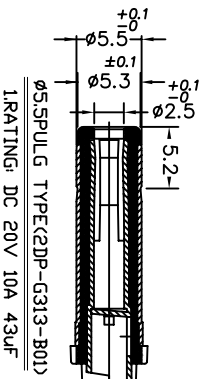
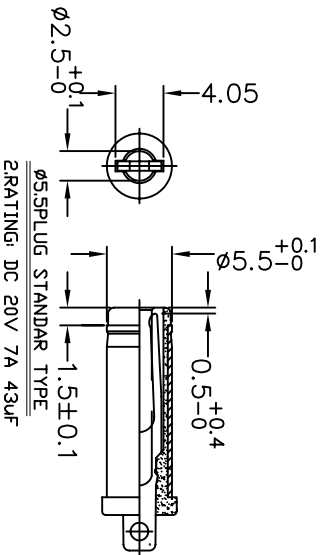
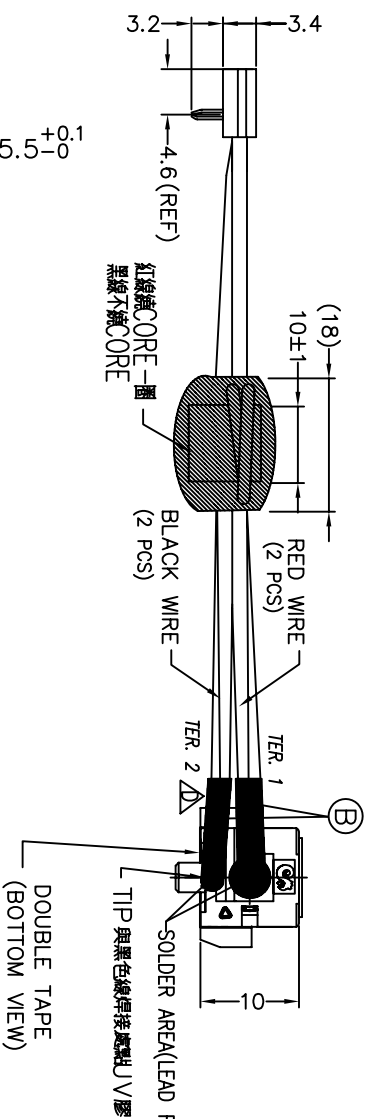
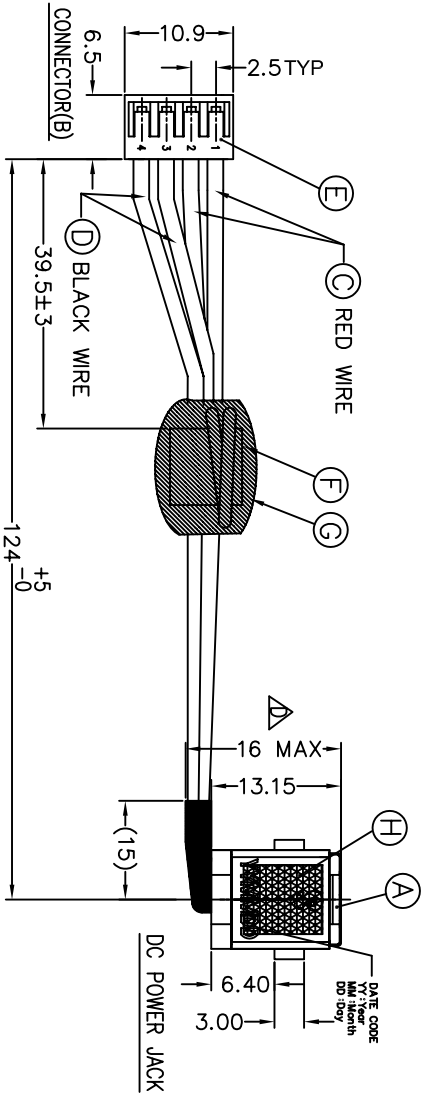

WIRE DIRGRAM		WIRE COLOR	CONNECTOR(B)
TERMINAL 1 (+)	RED COLOR	POS.(1,2)	
TERMINAL 2 (-)	BLACK COLOR	POS.(3,4)	

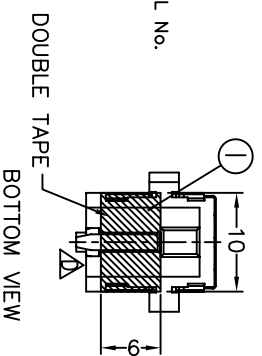
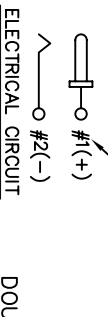

I	DOUBLE TAPE	1	L:6 * W:10 * T:0.06	N/A
H	GASKET	1	L:8 * W:7 * T:0.3	GRAY COLOR
G	HEAT SHRINKABLE TUBING	1	POLYOLEFINØ10(125.300V)	BLACK COLOR
F	CORE	1	OD:6*L:10*D:4	BLACK COLOR
E	CONNECTOR(B)	1	HOUSING: INCON 66 UL 94V-0	WHITE COLOR
		4	TERMINAL: BRASS	TIN PLATING
D	WIRE	2	UL 1430 #24 AWG	BLACK COLOR
C	WIRE	2	UL 1430 #24 AWG	RED COLOR
B	HEAT SHRINKABLE TUBING	2	POLYOLEFINØ5.5(125.300V)	BLACK COLOR
A	DC POWER JACK	1	SEE "SINGATRON P/N: 2DC-G233-B03"	
NO	DESCRIPTION	QTY	MATERIAL	PLATING & COLOR

UNLESS OTHERWISE SPECIFIED TOLERANCES

Singatron Enterprise Co., Ltd.  
信音企業股份有限公司

TITLE: DC POWER JACK-WIRE

DWN: 2007.04.06

CHKD: SCALE: ---

APVD: SIZE: A3

CUSTOMER COPY(SZ)

A  
B  
C  
D  
E  
F

1  
2  
3  
4  
5  
6  
7  
8