

REV.	ECN NO OR DESCRIPTION	REVISED	DATE
A	PDR NO:T100923-5A	QIANG	2011.01.07

- SPECIFICATIONS:
- 1.ELECTRICAL CHARACTERISTICS:
- 1-1.RATING:20V 3A
 - 1-2.CONTACT RESISTANCE:30mΩ MAX.(INITIAL)
 - 1-3.DIELECTRIC WITHSTANDING VOLTAGE:250V AC FOR ONE MINUTE.
 - 1-4.INSULATION RESISTANCE:100MΩ MIN. MEASURED BY 500V DC.
- 2.MECHANICAL CHARACTERISTICS:
- 2-1.INSERTION FORCE:3.0 KG MAX.
 - 2-2.WITHDRAWAL FORCE:0.5~3.0 KG.
- 3.LIFE TEST:5000 CYCLES MIN.
- 4.OTHER GENERAL SPEC. TO REFER "2DC-6756-B69 SPEC".
- 5.TO CONFORM TO SINGATRON HAZARDOUS SUBSTANCE FREE SPEC.
- 6.HALOGEN FREE PRODUCT IDENTIFICATION MARK ON JACK: ●
- 7.HALOGEN FREE PRODUCT IDENTIFICATION LABEL ON PACKAGING: ●

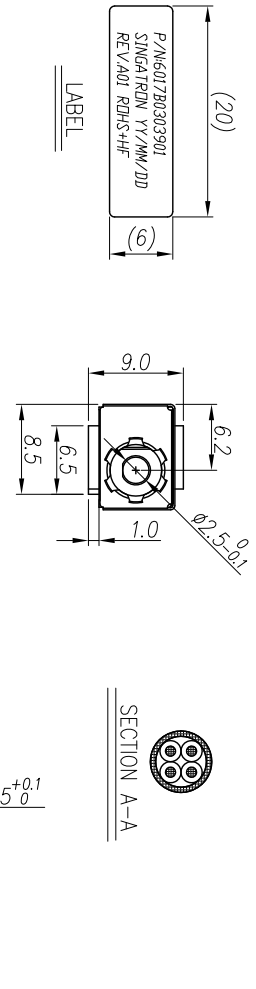

WIRE DIAGRAM		
DC JACK	WIRE COLOR	CONNECTOR
CENTER PIN(+)	RED	POS.(1,2)
SPRING(-)	BLACK	POS.(3,4)

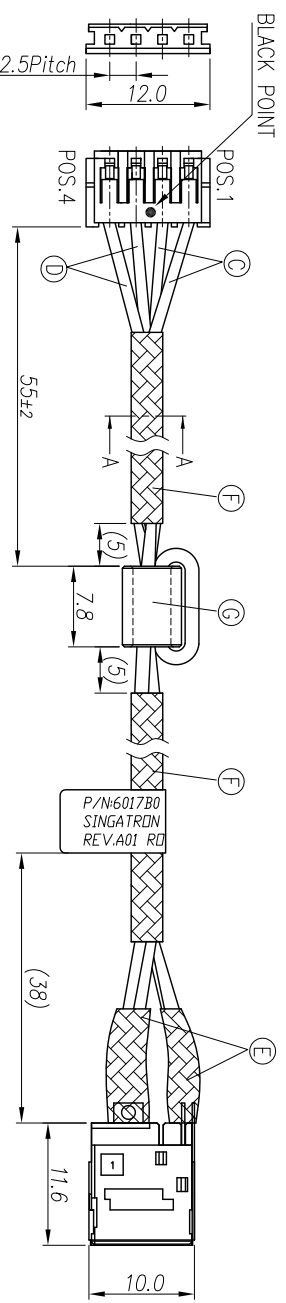
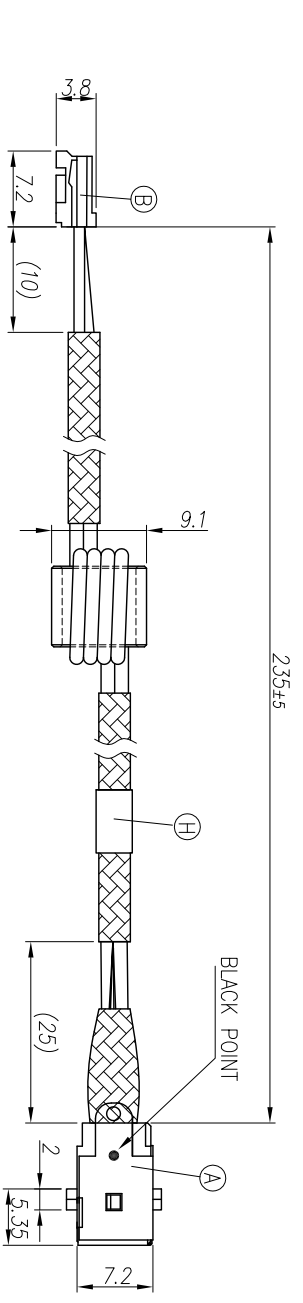
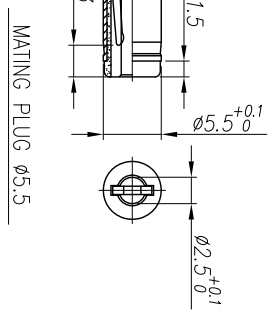

H	DESCRIPTION	QTY	MATERIAL	PLATING & COLOR
H	LABEL	1	20*6mm	WHITE
G	EMI CORE	1	9.1*5.6*7.8	BLACK
F	HEAT SHRINK TUBE	2	FOLYOLFEN Φ3.0mm(125°.300V)	BLACK
E	HEAT SHRINK TUBE	2	FOLYOLFEN Φ3.0mm(125°.300V)	BLACK
D	WIRE	2	UL10368 26AWG	BLACK
C	WIRE	2	UL10368 26AWG	RED
B	CONNECTOR	4	TERMINAL-PHOSPHOR BRONZE	TIN-PLATED
A	DC POWER JACK	1	HOUSING:NYLON66 UL 94V-0	WHITE
A	DC POWER JACK	1	TO SEE SINGATRON DC JACK P/N:2DC-6756-B69	

UNLESS OTHERWISE SPECIFIED TOLERANCES

DECIMALS: ANGLES:

X :±0.5 X :±2°

X.X :±0.3 X.X :±1°

X.XX :±0.2

TITLE	DC POWER JACK+WIRE
DWN	DATE:2011.01.07
CHKD	SCALE:--
APVD	UNIT: mm
	SIZE: A3
	SHEET:1 OF 1
	REV:A

Singatron Enterprise Co., Ltd.
信亨企業股份有限公司

CUSTOMER COPY