

REV.	ECN NO OR DESCRIPTION	REVISED	DATE
A	PDR No.:T120613-1A	Summer	2012.08.05
B	ECN NO.:S130837	YUREN	2014.02.09

SPECIFICATIONS:

1. ELECTRICAL CHARACTERISTICS:
- 1-1. RATING: 20V 12.5A
 - 1-2. CONTACT RESISTANCE: 30mΩ MAX. (INITIAL) (Only for DC Jack)
 - 1-3. INSULATION RESISTANCE: 100MΩ MIN.
 - 1-4. DIELECTRIC WITHSTANDING VOLTAGE: 150V RMS AFTER 1 MINUTE.
2. MECHANICAL CHARACTERISTICS:
- 2-1. INSERTION FORCE: 0.35~1.5KGf
 - 2-2. WITHDRAWAL FORCE: 0.35~1.5KGf
 3. LIFE TEST: 20000 CYCLES Min.
 4. OTHER GENERAL SPEC. TO REFER "2DC2018-005111F SPEC".
 5. TO CONFORM TO SINGATRON HAZARDOUS SUBSTANCE FREE SPEC.
 6. HALOGEN FREE PRODUCT IDENTIFICATION LABEL ON JACK: (C)
 7. HALOGEN FREE PRODUCT IDENTIFICATION LABEL ON PACKAGING: (E)
 8. THE PANEL'S ID MUST BE GREATER THAN THE PLUG'S OD WHICH MUST HAVE A DIFFERENCE OF LESS THAN OR EQUAL TO 0.5 mm. (AS SHOWN IN FIGURE 1.)

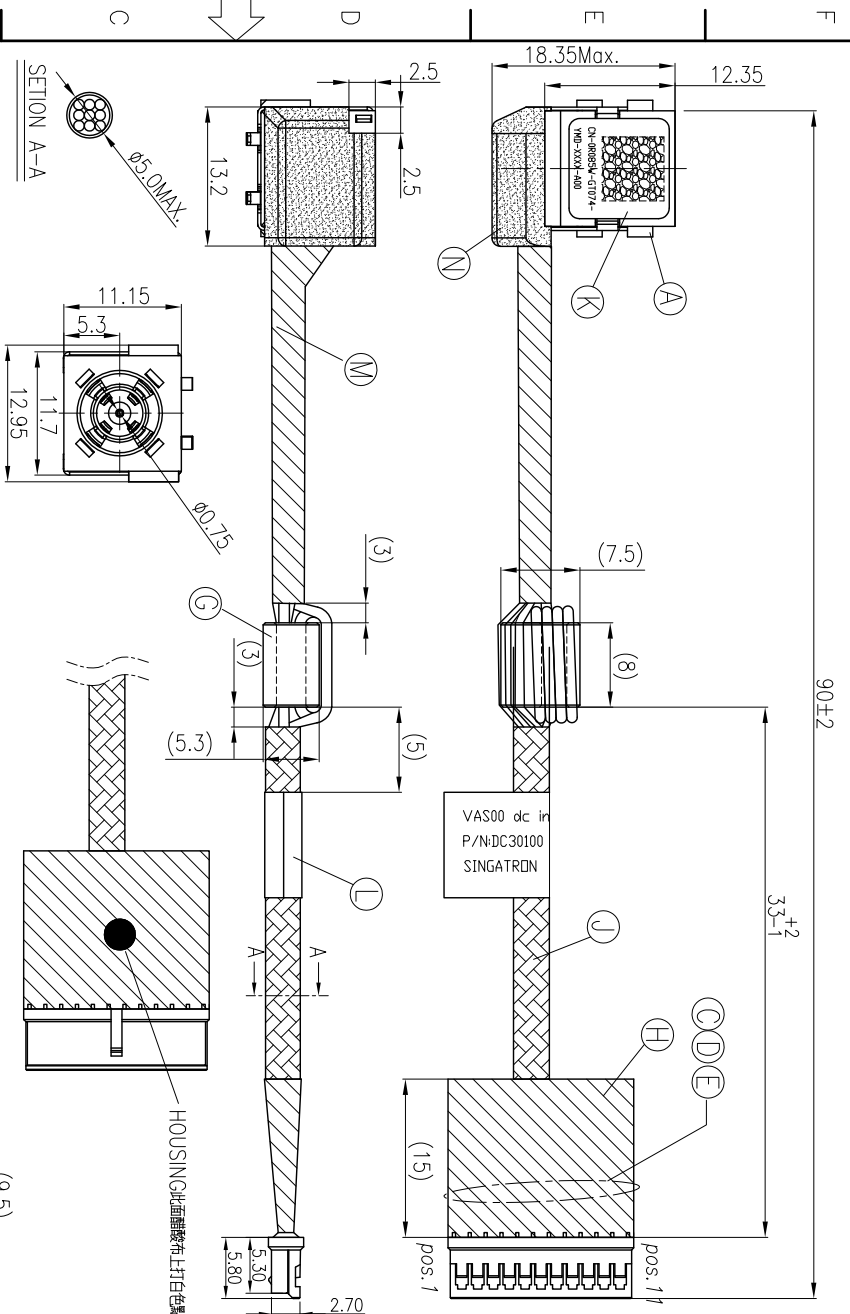
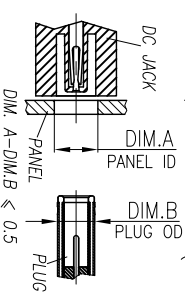
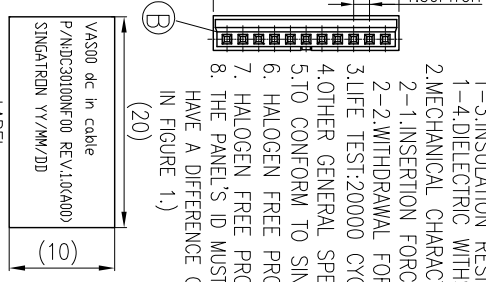

DC JACK	HOUSING	CABLE
20V	50V	300V
13A	3A/Per Pin	4.47A
OPERATION TEMPERATURE(°C)	-10 ~ 85	-25 ~ 85
RANGE(°C)	3.0 MAX.	105
重量 (KG)	0.4 MIN.	

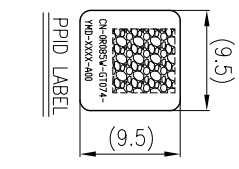

ITEM	DESCRIPTION	QTY	UNIT	REMARKS
N	MACROMELT	0.5g	MACROMELT 6208	AMBER
M	ACETATE CLOTH	1	W10*0.12T	BLACK
L	LABEL	1	20*10mm	WHITE
K	PPID LABEL	1	9.5*9.5mm	WHITE
J	HEAT SHRINK TUBE	1	FOLYUFEN φ4.0(125° 300V)	BLACK
H	ACETATE CLOTH	1	W15 *0.12T	BLACK
G	CORE	1	Model:NI-Mentn-600 Size:7.5*5.3*8 Manu:Sincores Electronics(D.G.)Corp	BLACK
E	WIRE	1	UL10368 26AWG	BROWN
D	WIRE	4	UL10368 26AWG	BLACK
C	WIRE	4	UL10368 26AWG	RED
B	CONNECTOR	9	TER. COPPER ALLOY	TIN-PLATED
A	DC JACK	1	HSG:THERMOPLASTIC UI94V-0	WHITE
NO			SINGATRON DC JACK P/N:2DC2018-005111F	PLATING & COLOR

CONNECTOR	WIRE COLOR	DC POWER JACK
pos. 1	BROWN (26AWG)	N/A
pos. 2	BLACK (26AWG)	SIGNAL (S)
pos. 3	BLACK (26AWG)	
pos. 4	BLACK (26AWG)	SPRING (-)
pos. 5	BLACK (26AWG)	
pos. 6	RED (26AWG)	
pos. 7	RED (26AWG)	
pos. 8	RED (26AWG)	SPRING (+)
pos. 9	RED (26AWG)	
pos. 10	RED (26AWG)	
pos. 11		N/A

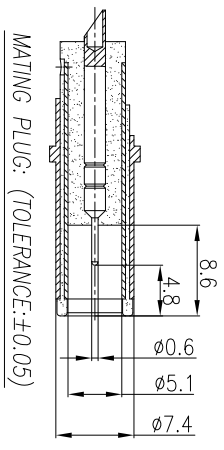

UNLESS OTHERWISE SPECIFIED TOLERANCES

Singaton Enterprise Co., Ltd.
信音企業股份有限公司

TITLE	DC JACK WITH WIRE
DWN	YUREN
CHKD	CERRY
APVD	MAX

PART NO. 2DW2018-010111F
SCALE: --
UNIT: mm
SIZE: A3
SHEET: 1 OF 1
REV: B

CUSTOMER COPY