

REV.	ECN NO OR DESCRIPTION	REVISED	DATE
A	PDR NO.T220804-3A	XIAO	2024.01.09

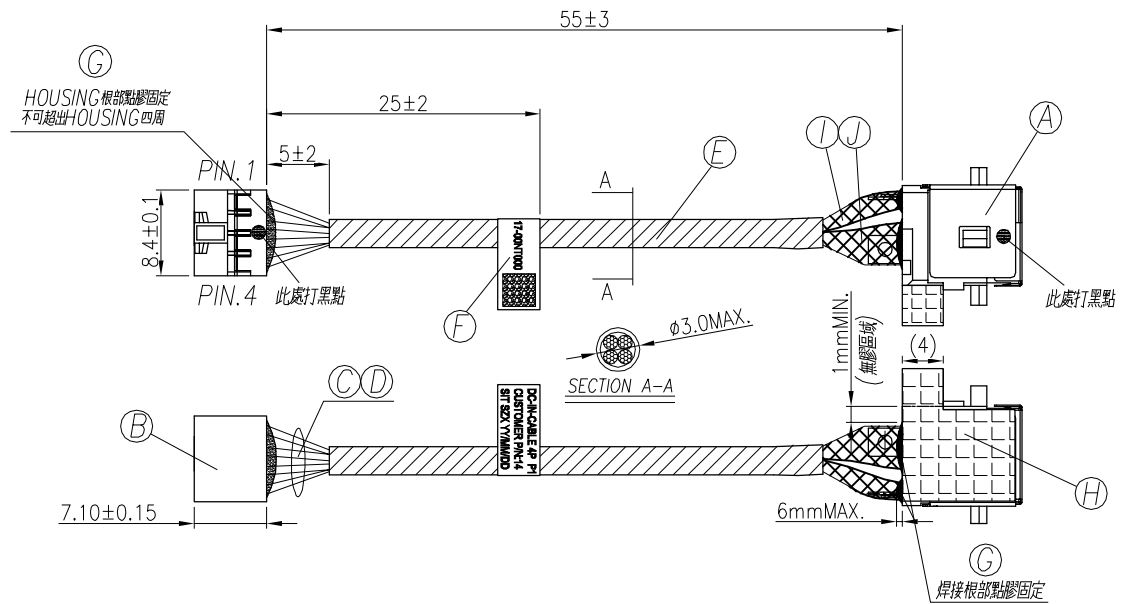

SPECIFICATIONS:

- DC POEWR JACK WITH WIRE AND WIRE TO BOARD CONNECTOR
 - RATING: 30V 3.6A
 - TEMPERATURE RISE : THE TEMPERATURE RISE SHALL NOT EXCEED 30 DEGREE C
- DC POEWR JACK- P/N: 2DC3120-002111F
 - RATING: 20V 7A
 - CONTACT RESISTANCE :30mΩMAX.(INITIAL)(ONLY FOR DC JACK)
 - DIELECTRIC WITHSTANDING VOLTAGE:500V AC FOR ONE MINUTE.
 - INSULATION RESISTANCE:100MΩMIN. MEASURED BY 500V DC.
 - INSERTION FORCE: 3.0 Kgf MAX.
 - WITHDRAWAL FORCE: 0.5~3.0Kgf
 - LIFT TEST: 5000 CYCLES
- WIRE TO BOARD CONNECTOR - VENDER : ACES P/N: 50303-004H0H0-001
 - RATING CURRENT : 3.0A /PER PIN (AWG #24 OR MORE)
- OTHER GENERAL SPEC. REFER TO "2DW3120-040111F SPEC."
- TO CONFORM TO SINGATRON HAZARDOUS SUBSTANCE FREE SPEC.
- HALOGEN FREE PRODUCT IDENTIFICATION MARK ON JACK:
- HALOGEN FREE PRODUCT IDENTIFICATION LOGO ON PACKAGING:
- PRINTED DATE CODE"YYMMDD" ON TOP OF JACK.

YY: YEAR
MM: MONTH
DD: DAY
- THE PANEL'S ID MUST BE GREATER THAN THE PLUG'S OD WHICH MUST HAVE A DIFFERENCE OF LESS THAN OR EQUAL TO 0.5 mm.(AS SHOWN IN FIGURE 1.)
- TEST CONDITION:
 - INSULATION RESISTANCE:20MΩMIN. MEASURED BY 500V DC.
 - DIELECTRIC WITHSTANDING VOLTAGE:500V AC FOR ONE MINUTE.
 - CONTACT RESISTANCE :2 OHM MAX.
 - OPEN/SHORT:100% TEST

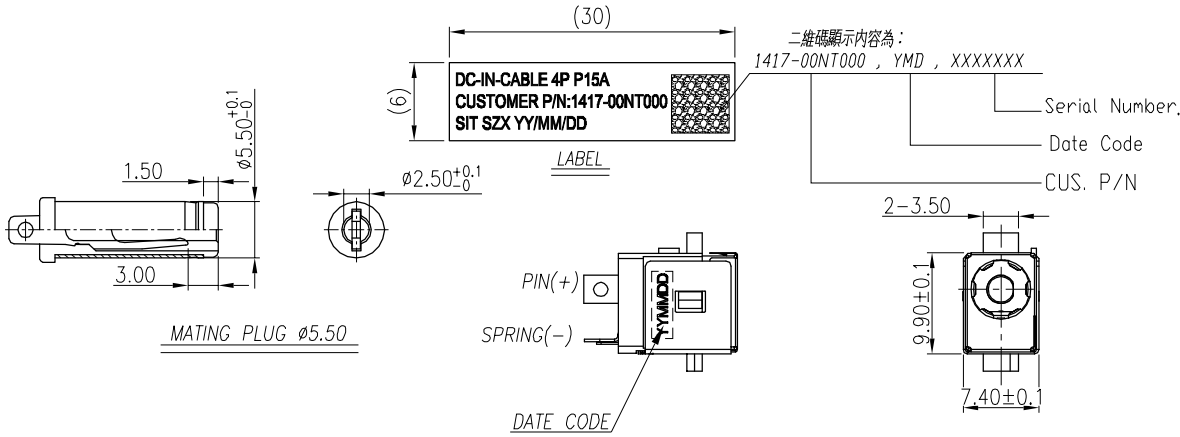

CONNECTOR	DC JACK	CABLE TYPE/AWG#	COLOUR
PIN.1	SPRING(-)	UL10064 24AWG VW-1	BLACK
PIN.2	SPRING(-)	UL10064 24AWG VW-1	
PIN.3	PIN(+)	UL10064 24AWG VW-1	RED
PIN.4	PIN(+)	UL10064 24AWG VW-1	

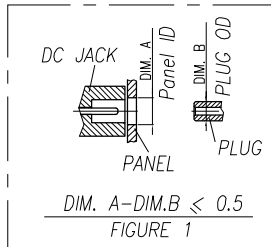

J	HEAT SHRINK TUBE	1	φ3.5(125°,300V)	BLACK
I	HEAT SHRINK TUBE	1	φ3.0(125°,300V)	BLACK
H	ADHESIVE TAPE	1	G9000	WHITE
G	UV GLUE	2	UV GLUE	WHITE
F	LABEL	1	L30*W6	WHITE
E	ACETATE TAPE	1	T0.12	BLACK
D	WIRE	2	UL10064 24AWG VW-1 (清線)	BLACK
C	WIRE	2	UL10064 24AWG VW-1 (清線)	RED
B	CONNECTOR (HSG :ACES 50303-004H0H0-001) (TER :ACES 88301-W-GOLD FLASH)	4	TER:PHOSPHOR BRONZE	GOLD FLASH
		1	HSG:NYLON 66 UL 94V-0	WHITE
A	DC POWER JACK	1	SINGATRON DC POWER JACK P/N:2DC3120-002111F	
NO	DESCRIPTION	QTY	MATERIAL	PLATING & COLOR

UNLESS OTHERWISE SPECIFIED TOLERANCES

Singatron Enterprise Co., Ltd.
信音企業股份有限公司

DECIMALS:	ANGLES:	TITLE	DC POWER JACK WITH WIRE HARNESS	
X :±0.5	X :±2°	DWN	XIAO	PART NO.2DW3120-040111F
X.X :±0.3	X.X :±1°	CHKD	ALLEN	SCALE:-- UNIT: mm
X.XX :±0.2		APVD	BOYE	SIZE: A3 SHEET:1 OF 2

REV:A

CUSTOMER COPY

REV.	ECN NO OR DESCRIPTION	REVISED	DATE
A	PDR NO.T220804-3A	XIAO	2024.01.09

1. 負極先接觸狀態：

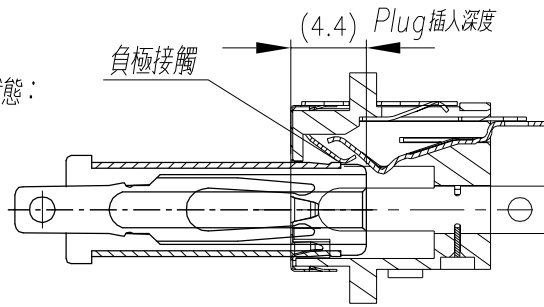

2. 正極接觸狀態：

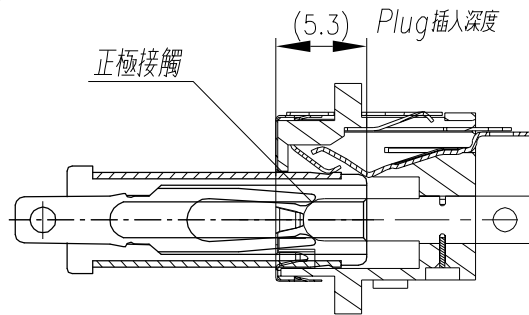

3. Lock 狀態狀態：

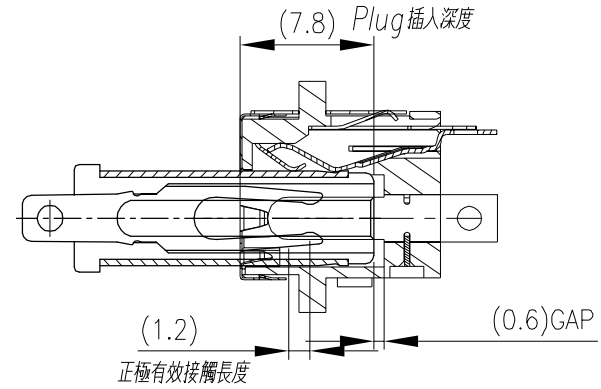

4. Full Mating 狀態：

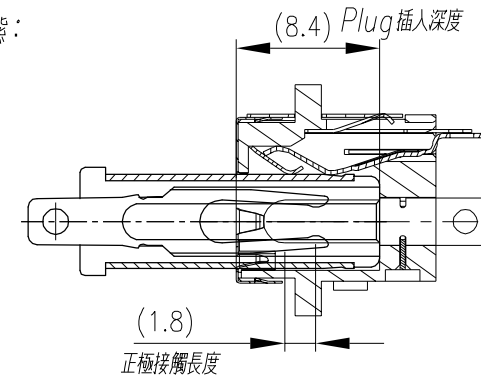

ITEM	DESCRIPTION	QTY	MATERIAL	PLATING & COLOR
UNLESS OTHERWISE SPECIFIED TOLERANCES		 Singatron Enterprise Co., Ltd. 信音企業股份有限公司		
DECIMALS:	ANGLES:	TITLE	DC POWER JACK_MATING DRAWING	
X :±0.5	X :±2°	DWN	XIAO	PART NO.2DW3120-040111F
X.X :±0.3	X.X :±1°	CHKD	ALLEN	SCALE -- UNIT: mm
X.XX :±0.2		APVD	BOYE	SIZE: A3 SHEET:2 OF 2 REV:A
CUSTOMER COPY				