

REV.	ECN NO.	OR DESCRIPTION	REVISED	DATE
A	DCN NO.T150923-10A		Meifeng	2016.12.28
B	ECN NO.S170236-C		Ken	2017.04.06
C	ECN NO.S170927-E		Ken	2017.12.1

SPECIFICATIONS:
 1.ELECTRICAL CHARACTERISTICS:
 1-1.RATING:19V 3.3A
 1-2.CONTRACT RESISTANCE:30mΩ MAX.(INITIAL ONLY FOR DC JACK)
 1-3.IDELECTRIC WITHSTANDING VOLTAGE:500V AC FOR ONE MINUTE.
 1-4.INSULATION RESISTANCE:100MΩ MIN. MEASURED BY 500V DC.
 2.MECHANICAL CHARACTERISTICS:
 2-1.INSERTION FORCE:1.2~2.7kgf(INITIAL); 1.0~2.7kgf (AFTER LIFE TEST)
 2-2.WITHDRAWAL FORCE:1.0~2.7kgf (INITIAL & AFTER LIFE TEST)
 3.LIFE TEST:5000 CYCLES MIN.

4.OTHER GENERAL SPEC. TO REFER "2DW3127-012111F SERIES SPEC".
 5.TO CONFORM TO SINGATRON HAZARDOUS SUBSTANCE FREE SPEC.
 6.HALOGEN FREE PRODUCT IDENTIFICATION MARK ON JACK.☉
 7.HALOGEN FREE PRODUCT IDENTIFICATION LABEL ON PACKAGING.☉
 8.PRINTED DATE CODE" YMMDD " ON TOP OF CONNECTOR.
 DATE CODE:YMMDD (YY:YEAR MM:MONTH DD:DAY)

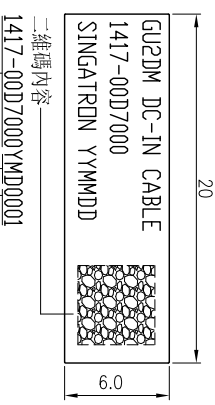
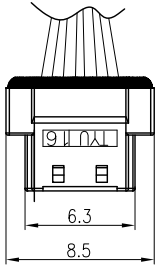
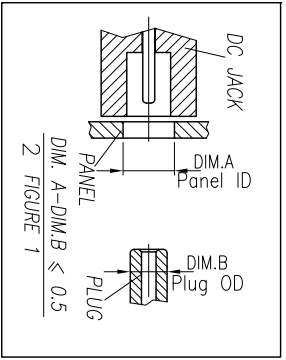
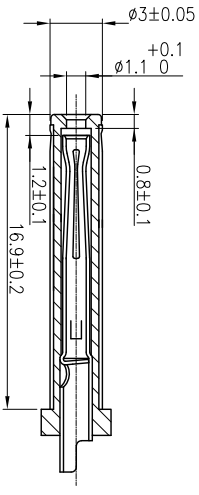
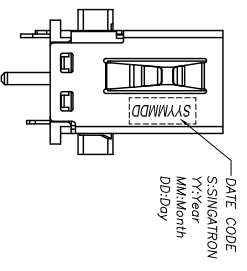
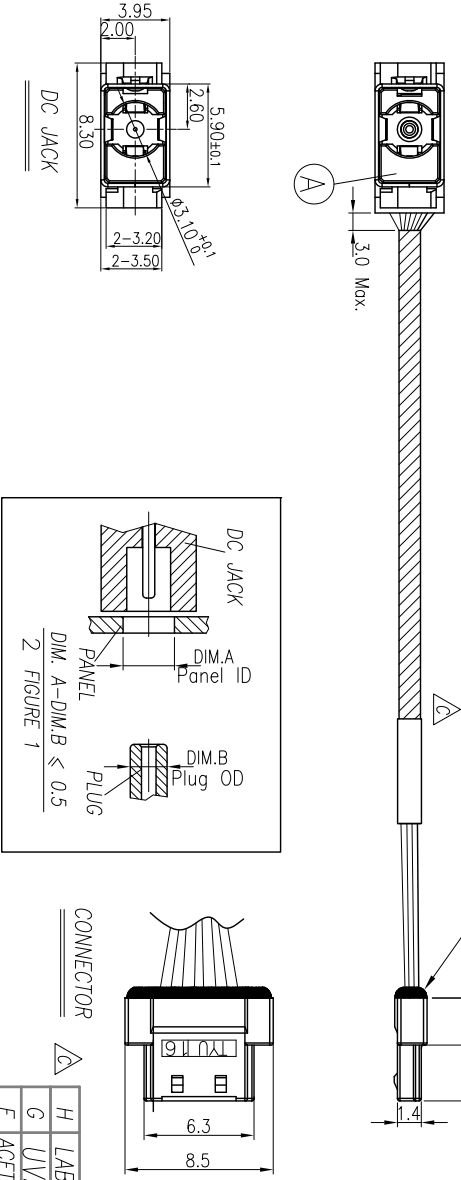
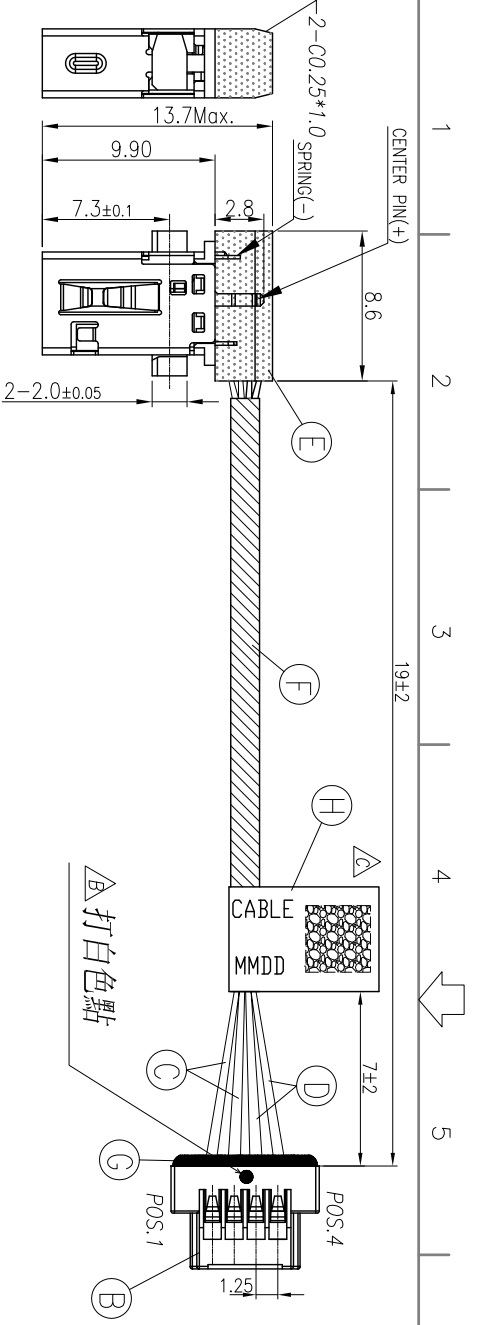

1417-00D7000YMMDD001
 SERIAL NO.(0~9, A~Z)
 DATE CODE
 PEGA P/N
 *0代表數字*0*
 *□代表字母*0*

WIRE DIAGRAM			
DC JACK	WIRE COLOR	CONNECTOR	
CENTER PIN(+)	RED	POS.(1,2)	
SPRING(-)	BLACK	POS.(3,4)	

H	LABEL	1	L20*W6	WHITE COLOR
G	UV膠	N/A	8860 膠電子	WHITE COLOR
F	ACETATE CLOTH TAPE	1	W12*H0.12	BLACK COLOR
E	MACROMELT	0.3g	MACROMELT 6208	AMBER COLOR
D	WIRE	2	UL10064 28AWG	BLACK
C	WIRE	2	UL10064 28AWG	RED
B	CONNECTOR	4	TER:Phosphor Bronze	TIN-PLATED
A	DC JACK	1	HSG:Nylon 66 UL94V-0	BLACK
NO	DESCRIPTION	1	TO SEE SINGATRON DC P/N:2DC3127-000111F	
			MATERIAL	PLATING & COLOR

UNLESS OTHERWISE SPECIFIED TOLERANCES

DECIMALS: ANGLES:

X :±0.5 X :±2°
 X.X :±0.3 X.X :±1°
 X.XX :±0.2

DC JACK WITH WIRE

PART NO.2DW3127-012111F

SCALE:-- UNIT: mm

SIZE: A3 SHEET:1 OF 1 REV:C

CUSTOMER COPY

Singatron Enterprise Co., Ltd.
 信普企業股份有限公司