

REV.	ECN NO.	OR DESCRIPTION	REVISED	DATE
A	PDR NO.:S150520-4A		Lin	2015.05.12
B	ECN NO.:S151212-C		Vicky	2016.03.16
C	ECN NO.: S160801-R		Harlen	2016.08.01

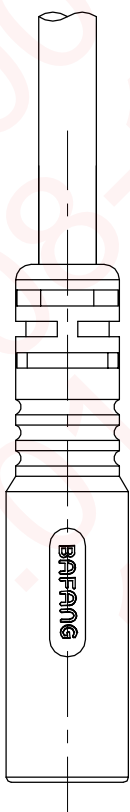
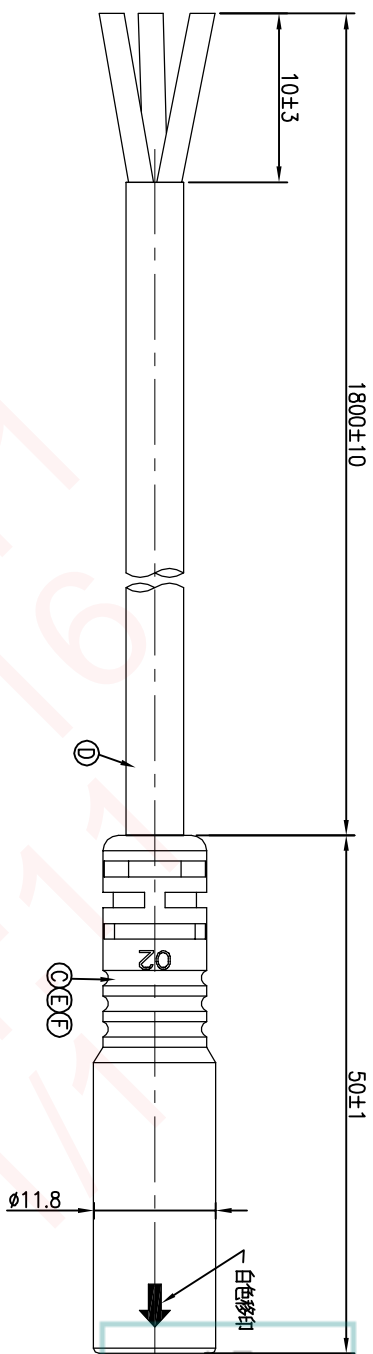

A VIEW

3	YELLOW
2	BLUE
1	GREEN
CONN.	WIRE COLOR

PIN OUT

CONN.

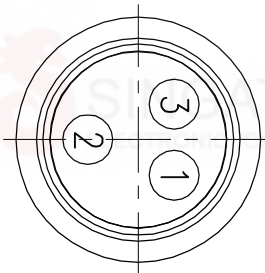

Pin Assignments
Front View

- NOTES:
1. WATERPROOF RATE: IP65
 2. CURRENT RATING: 10A
 3. CONTACT RESISTANCE: 3 Ohm Max.
 4. HI-POT TEST 800V AC, 5mA(1SEC)
 5. INSULATION RESISTANCE: 30Mohm MIN. BY 500V DC
 6. SPECIFICATIONS:SEE "E-BIKE SERIES SPECIFICATIONS"
 7. TO CONFORM TO THE SINGATRON HAZARDOUS SUBSTANCE FREE SPEC.
 8. GREEN PRODUCT IDENTIFICATION LABEL ON PACKAGING:

E	INNER MOLD	1	PVC	BLACK
D	CABLE	1	16#*3C+24#*3C OD5.6	BLACK(PVC JACKET)
C	OVER MOLD	1	HYTREL	BLACK
B	FEMALE PIN	3	Phosphor Bronze	1~3u" GOLD PLATING OVER NICKEL PLATING
A	BODY	1	PA66+GF	BLACK
NO	DESCRIPTION	QTY	MATERIAL	PLATING & COLOR

UNLESS OTHERWISE SPECIFIED TOLERANCES

DECIMALS: ANGLES:

X :±0.5 X :±2
X.X :±0.3 X.X :±1'
X.XX :±0.2

Singatron Enterprise Co., Ltd.
信管企業股份有限公司

TITLE: E-BIKE SERIES 180° 3 PIN FEMALE CONN.
DWG: Vicky PART NO. 2EB3004-W03432H
CHKD: Harlen SCALE 2:1 UNIT: mm
APVD: Steve SIZE: A3 SHEET: 1 OF 1 REV: C

CUSTOMER COPY