

REV.	ECN NO OR DESCRIPTION	REVISED	DATE
A	PDR NO.:S160713-9A	Vcky	2016/07.14

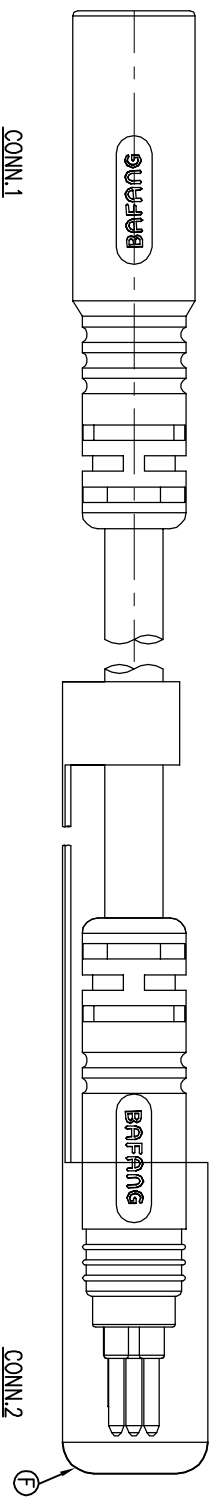

CONN.1	WIRE COLOR	CONN.2
3	YELLOW	3
2	BLUE	2
1	GREEN	1

PIN OUT

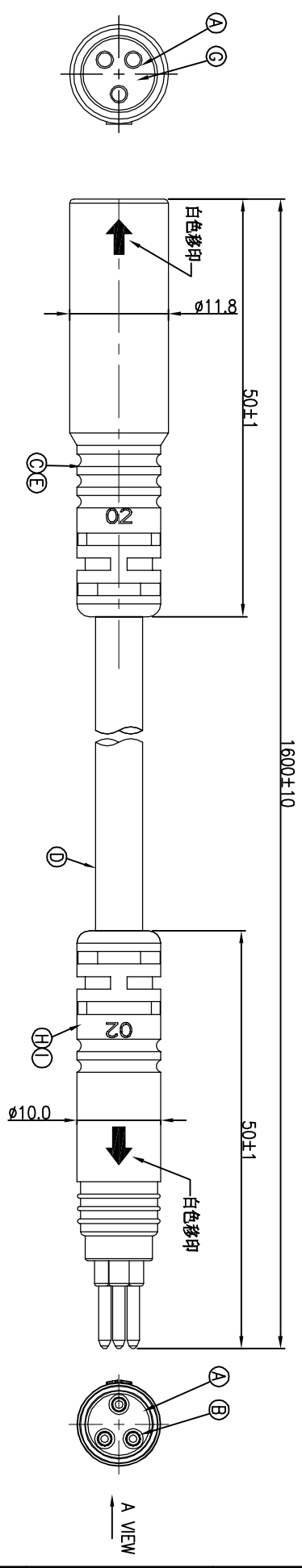
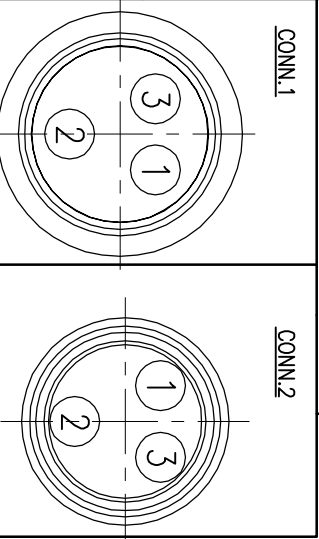

NOTES:

1. WATERPROOF RATE: IP65
2. CURRENT RATING: 10A
3. CONTACT RESISTANCE: 3 Ohm Max.
4. HI-POT TEST: 800V AC, 5mA(1SEC)
5. INSULATION RESISTANCE: 30Mohm MIN. BY 500V DC
6. SPECIFICATIONS:SEE "E-BIKE SERIES SPECIFICATIONS."
7. TO CONFORM TO THE SINGATRON HAZARDOUS SUBSTANCE FREE SPEC.
8. GREEN PRODUCT IDENTIFICATION LABEL ON PACKAGING:

NO	DESCRIPTION	QTY	MATERIAL	PLATING & COLOR
I	OVER MOLD	1	TPU	BLACK
H	INNER MOLD	1	ABS	NATURAL
G	FEMALE PIN	3	Phosphor Bronze	1~3u" GOLD PLATING OVER NICKEL PLATING
F	CAP	1	PA66	NATURAL
E	INNER MOLD	1	PVC	BLACK
D	CABLE	1	16#*3C 05.6	BLACK(PVC JACKET)
C	OVER MOLD	1	HYREL	BLACK
B	MALE PIN	3	BRASS	1~3u" GOLD PLATING OVER NICKEL PLATING
A	BODY	2	PA66+GF	BLACK

UNLESS OTHERWISE SPECIFIED TOLERANCES

DECIMALS: ANGLES:

X	:±0.5	X	:±2°
X.X	:±0.3	X.X	:±1'
X.XX	:±0.2		

Singatron Enterprise Co., Ltd.  
信譽企業股份有限公司

TITLE E-BIKE SERIES 180° 3 PIN CONN.

DWN Vcky PART NO.2EB3004-W03444H

CHKD Horten SCALE 2:1 UNIT: mm

APVD Steve SIZE: A3 SHEET:1 OF 1 REV: A

CUSTOMER COPY