

REV.	ECN NO.	OR DESCRIPTION	REVISED	DATE
D	ECN NO.: S140204		Vicky	2014.02.08
E	ECN NO.: S140336		Harlen	2014.3.25
F	ECN NO.: S151212-C		Vicky	2016.03.16
G	ECN NO.: S160801-R		Yang	2016.08.01

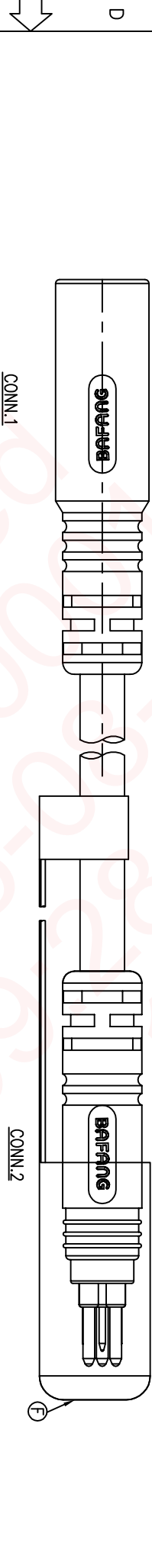
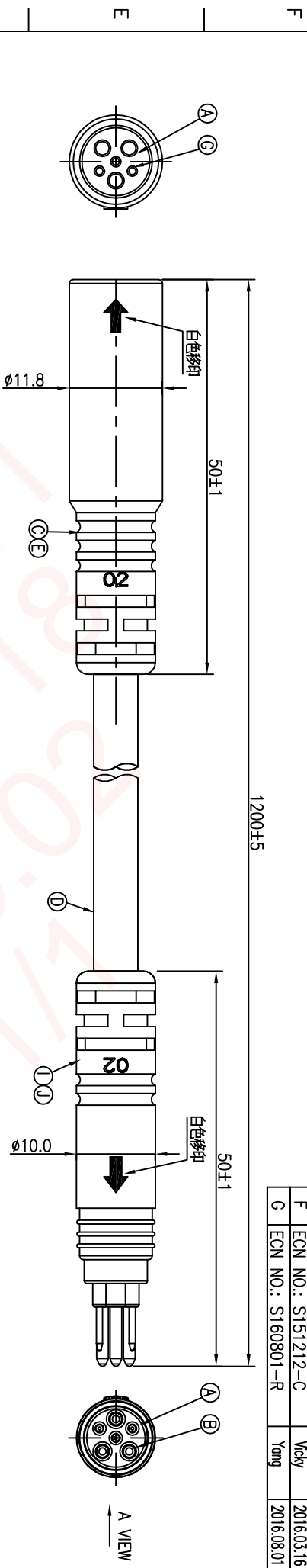

6	BLACK	6
5 <td>YELLOW <td>5</td> </td>	YELLOW <td>5</td>	5
4 <td>WHITE <td>4</td> </td>	WHITE <td>4</td>	4
3 <td>BLUE <td>3</td> </td>	BLUE <td>3</td>	3
2 <td>RED <td>2</td> </td>	RED <td>2</td>	2
1 <td>GREEN <td>1</td> </td>	GREEN <td>1</td>	1

CONN.1 WIRE COLOR CONN.2

PIN OUT

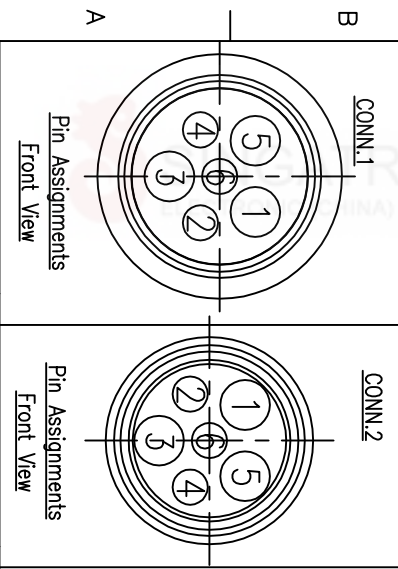

- NOTES:
1. WATERPROOF RATE: IP65
 2. CURRENT RATING: 10A+2A
 3. CONTACT RESISTANCE: 3 Ohm Max
 4. HI-POT TEST 800V AC, 5mA(1SEC)
 5. INSULATION RESISTANCE: 30Mohm MIN. BY 500V DC
 6. SPECIFICATIONS: SEE "E-BIKE SERIES SPECIFICATIONS."
 7. TO CONFORM TO THE SINGATRON HAZARDOUS SUBSTANCE FREE SPEC.
 8. GREEN PRODUCT IDENTIFICATION LABEL ON PACKAGING:

J	INNER MOLD	1	ABS	NATURAL
I	OVER MOLD	1	TPU	BLACK
H	SHRINK TUBE	6	Ø1.5mm 300V	BLACK
G	FEMALE PIN	6	Phosphor Bronze	1~3u" GOLD PLATING OVER NICKEL PLATING
F	CAP	1	PA66	NATURAL
E	INNER MOLD	1	PVC	BLACK
D	CABLE	1	16#*3C+24#*3C OD6.2	BLACK(PVC JACKET)
C	OVER MOLD	1	HYTREL	BLACK
B	MALE PIN	6	BRASS	1~3u" GOLD PLATING OVER NICKEL PLATING
A	BODY	2	PA66+GF	BLACK

NO	DESCRIPTION	QTY	MATERIAL	PLATING & COLOR
UNLESS OTHERWISE SPECIFIED TOLERANCES				
TITLE E-BIKE SERIES 180° 6 PIN CONN.				
Singatron Enterprise Co., Ltd. 信管企業股份有限公司				

DECIMALS:	ANGLES:
X : ±0.5	X : ±2
X.X : ±0.3	X.X : ±1
X.XX : ±0.2	

DWN	Yong	PART NO. ZEB3004-W06911H
CHKD	JF	SCALE 2:1 UNIT: mm
APVD	Harlen	SIZE: A3 SHEET: 1 OF 1 REV: G

CUSTOMER COPY