

REV	ECN NO	OR DESCRIPTION	REVISED	DATE
C	ECN NO.: S121345		Vicky	2013.12.19
D	ECN NO.:S140336		Harlen	2014.3.25
E	ECN NO.: S151212-C		Vicky	2016.03.16
F	ECN NO.: S160801-R		Yong	2016.08.01

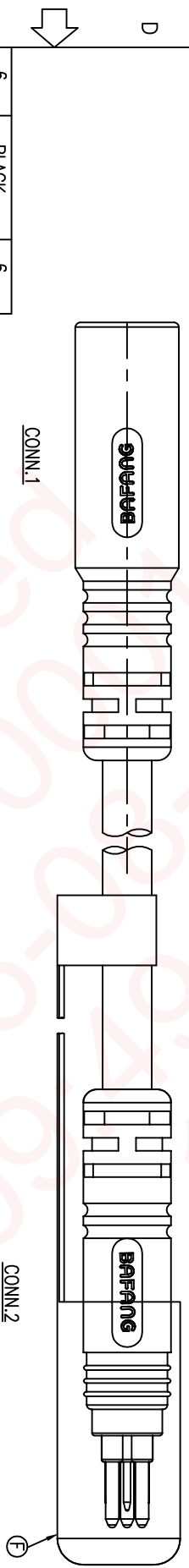

CONN.1	WIRE COLOR	CONN.2
1	GREEN	1
2	RED	2
3	BLUE	3
4	WHITE	4
5	YELLOW	5
6	BLACK	6

PIN OUT

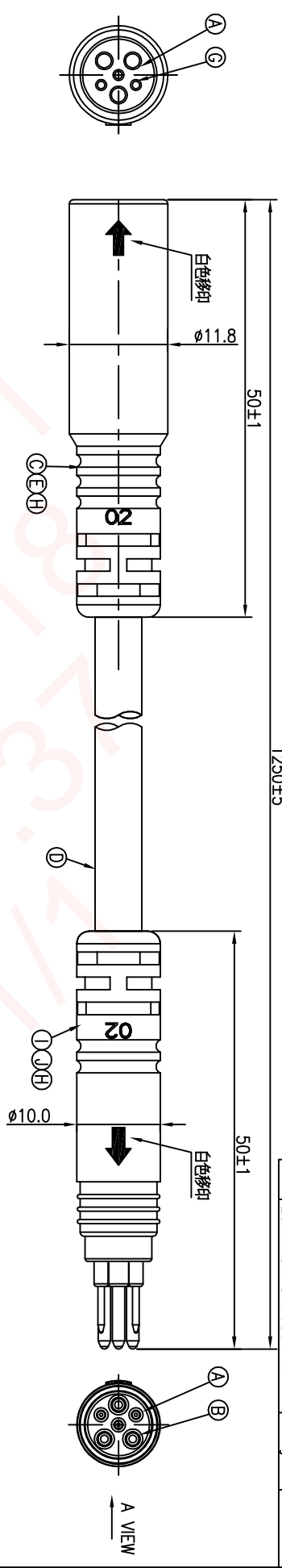
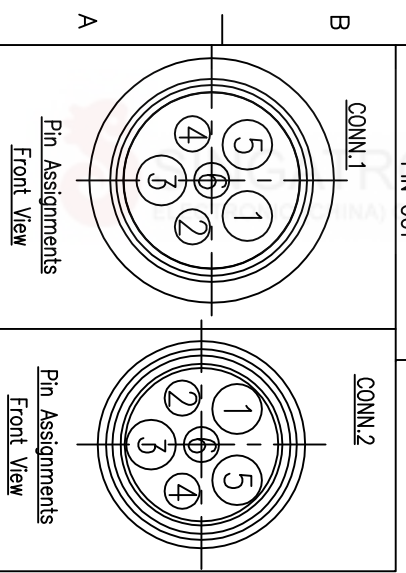

- NOTES:
1. WATERPROOF RATE: IP65
 2. CURRENT RATING: 10A+2A
 3. CONTACT RESISTANCE: 3 Ohm Max
 4. HI-POT TEST 800V AC, 5mA(1SEC)
 5. INSULATION RESISTANCE: 30Mohm MIN. BY 500V DC
 6. SPECIFICATIONS:SEE "E-BIKE SERIES SPECIFICATIONS."
 7. TO CONFORM TO THE SINGATRON HAZARDOUS SUBSTANCE FREE SPEC.
 8. GREEN PRODUCT IDENTIFICATION LABEL ON PACKAGING:

CONN.2

J	INNER MOLD OVER MOLD	1	ABS	NATURAL
I	OVER MOLD	1	TPU	BLACK
H	SHRINK TUBE	6	Ø1.5mm 300V	BLACK
G	FEMALE PIN	6	Phosphor Bronze	1~3u" GOLD PLATING OVER NICKEL PLATING
F	CAP	1	PA66	NATURAL
E	INNER MOLD	1	PVC	BLACK
D	CABLE	1	16#*3C+24#*3C Ø6.2	BLACK(PVC JACKET)
C	OVER MOLD	1	HYTREL	BLACK
B	MALE PIN	6	BRASS	1~3u" GOLD PLATING OVER NICKEL PLATING
A	BODY	2	PA66+GF	BLACK

UNLESS OTHERWISE SPECIFIED TOLERANCES

DECIMALS:	ANGLES:
X :±0.5	X :±2
X.X :±0.3	X.X :±1
X.XX :±0.2	

TITLE E-BIKE SERIES 180° 6 PIN CONN.

DWN Yong PART NO.2EBB3004-W06912H

CHKD JF SCALE 2:1 UNIT: mm

APVD Harlen SIZE: A3 SHEET:1 OF 1 REV:F

Singatron Enterprise Co., Ltd.
信亨企業股份有限公司

CUSTOMER COPY